

STAPEL



education

Department of
Education
FREE STATE PROVINCE

ENGINEERING GRAPHICS AND DESIGN

GRADE 10

TEST

MARCH 2019

TIME: 1 HOUR

TOTAL: 60

This question paper consists of 3 pages

INSTRUCTIONS AND INFORMATION

1. This question paper consists of TWO questions.
2. Answer ALL the questions.
3. ALL drawings must be drawn to scale 1:1, unless stated otherwise.
4. ALL questions must be answered on the DIAGRAM SHEETS, as instructed.
5. ALL the pages must be stapled in numerical sequence, irrespective of whether the question was attempted or not.
6. Time management is essential in order to complete all the questions.
7. Print your name and surname as well as the grade in the space provided on each page.
8. ALL answers must be drawn accurately and neatly.
9. ALL necessary construction and projection lines must be shown.
10. Plan each drawing carefully from the given position, which is indicated on the diagram sheets.
11. Any details or dimensions not given must be assumed in good proportion.

FOR OFFICIAL USE ONLY								
QUESTION	MARKS OBTAINED			½	MODERATED			½
1								
2								
TOTAL								
		6	0			6	0	

FINAL CONVERTED MARK	CHECKED BY
60	

NAME & SURNAME	MEMORANDUM	GRADE	10	1
----------------	-------------------	-------	-----------	----------

STAPEL

QUESTION 1: FREE HAND DRAWING

Given:

Diagram sheet 1 (page 2) shows an illustration of a house drawn within a frame.

Instructions:

- 1.1. Use point P as the starting position.
- 1.2. Make use of your drawing instruments (T-square, ruler and set-square) and draw, according to a scale of 2:1 the given grid block. The line quality should be construction lines.
- 1.3. In continuous thick (visible outline) line quality, copy the given house FREE HAND by using the grid block method.

Note:

- Show all construction lines.

[20]

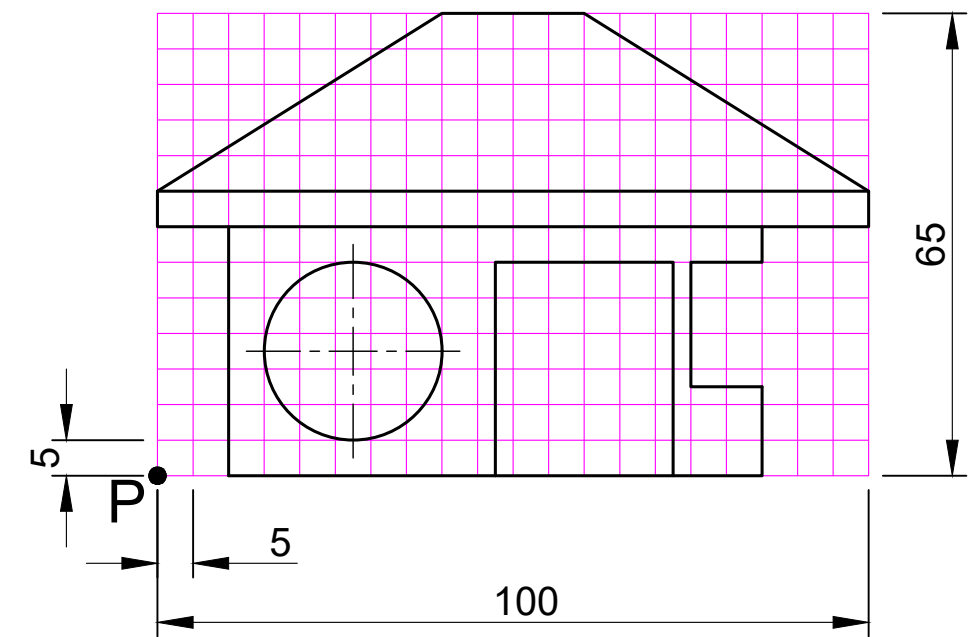
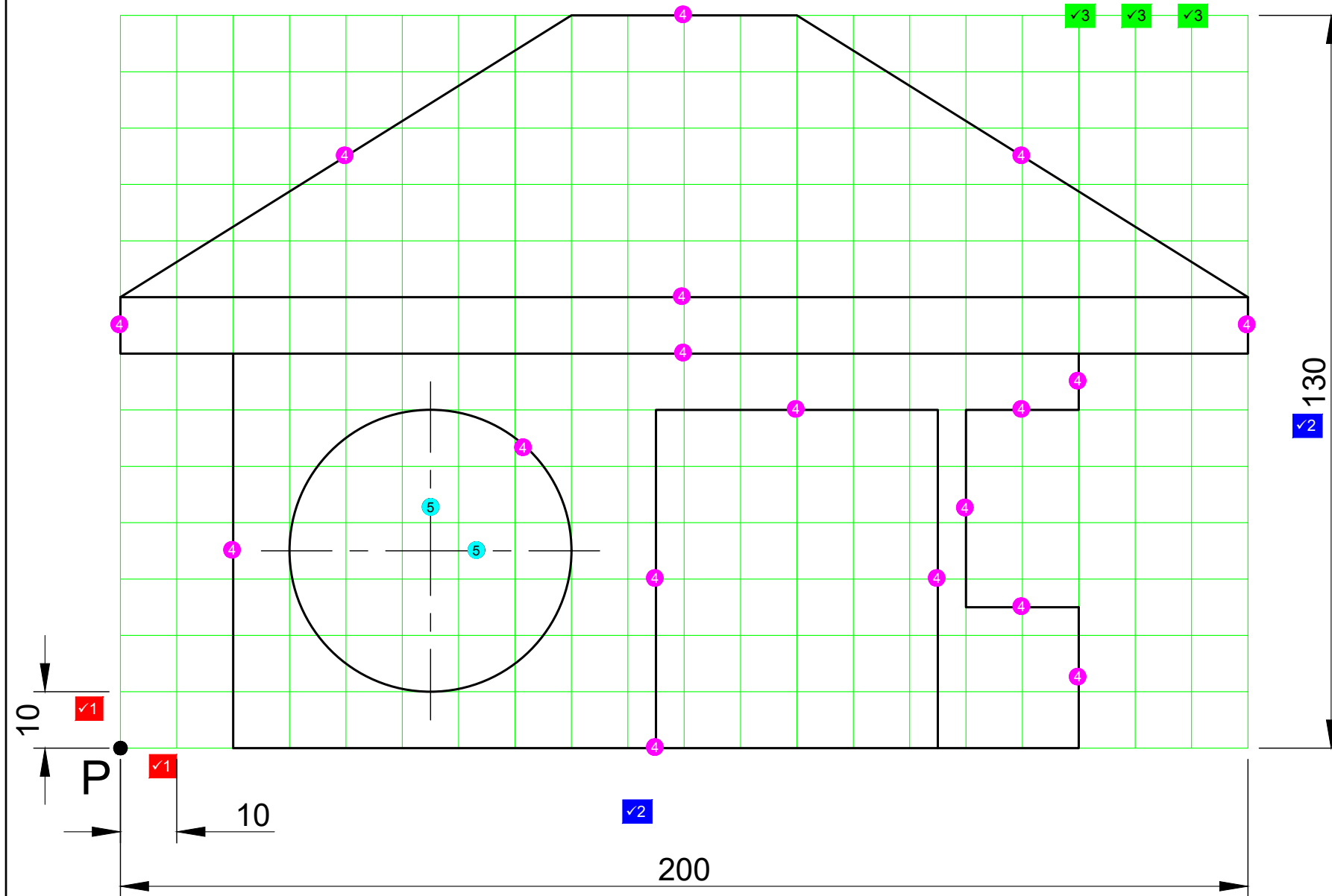

3. NOTES ON THE BLOCK

- Lines are parallel with each other (Max 2). ✓3
- Construction line quality (Max 2). ✓3
- 10 mm block sizes (Max 2). ✓3

ASSESSMENT CRITERIA				
1	START POSITION	✓1	2	
2	CORRECT SCALE	✓2	2	
3	BLOCK	✓3	6	
4	HOUSE (18/2) (Freehand max - 6/2)	4	9	
5	CENTRE LINES (2)	5	1	
TOTAL			20	

QUESTION 2: GEOMETRICAL CONSTRUCTION

Given:

Diagram sheet 2 (page 3) shows a representation of a headlight of a vehicle with the necessary dimensions.

Instructions:

Use the given sketch on diagram sheet 2 with point A as the starting position and with a scale of 1:1, construct by means of your drawing equipment the following:

- 1.1. A perpendicular line as a construction line from point A to line segment BC and name the intersection point through BC, D.
- 1.2. By means of construction, bisect the angle ADB and draw the line as a centre line (medium chain line). Extend the line to a perpendicular height of 96 mm from point D. Name this line DE.
- 1.3. By means of your T-square, draw a dashed thin line (short dashed or hidden detail outline), 45 mm in length to the left and name this line EF.
- 1.4. Determine the start positions and by means of your compass, construct and name circle G (R40 mm) and circle H (R20 mm) as a continuous thick (visible outline) line quality.
- 1.5. By means of your T-square, join point D with a tangent as a continuous thin (construction line) to the bottom of circle H and name the intersection point J.
- 1.6. By means of construction, divide line segment DJ in 6 equal parts. Show all construction lines and name each divide line from 1 to 6.
- 1.7. Construct a fillet as a continuous thick (visible outline) line with a radius of 30 mm between line segment DE and EF.
- 1.8. Construct an external arc as a continuous thick (visible outline) line with a radius of 90 mm to circles G & H, including last mentioned circles with the external arc.

Note:

- Show ALL construction lines.
- Show ALL calculation.

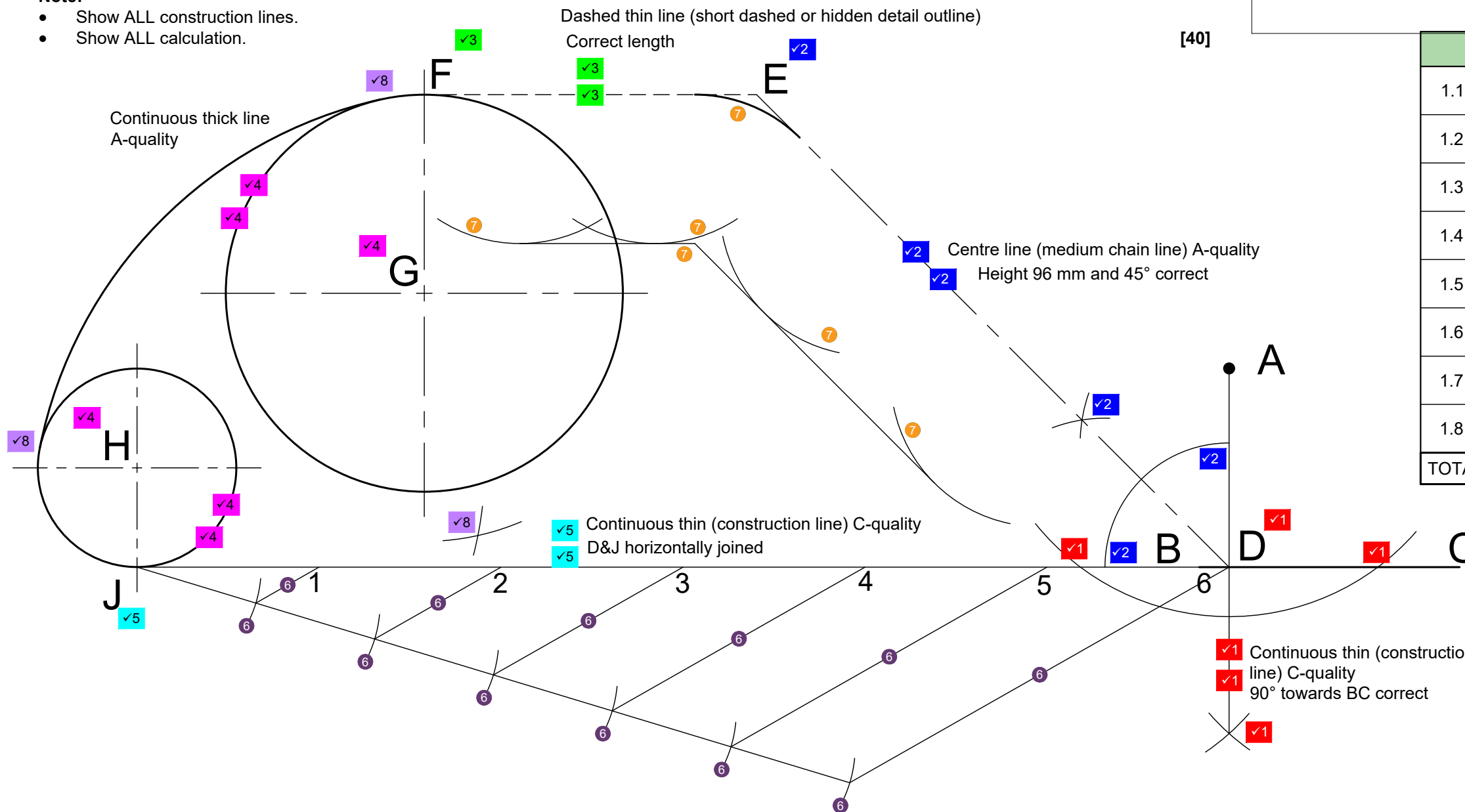
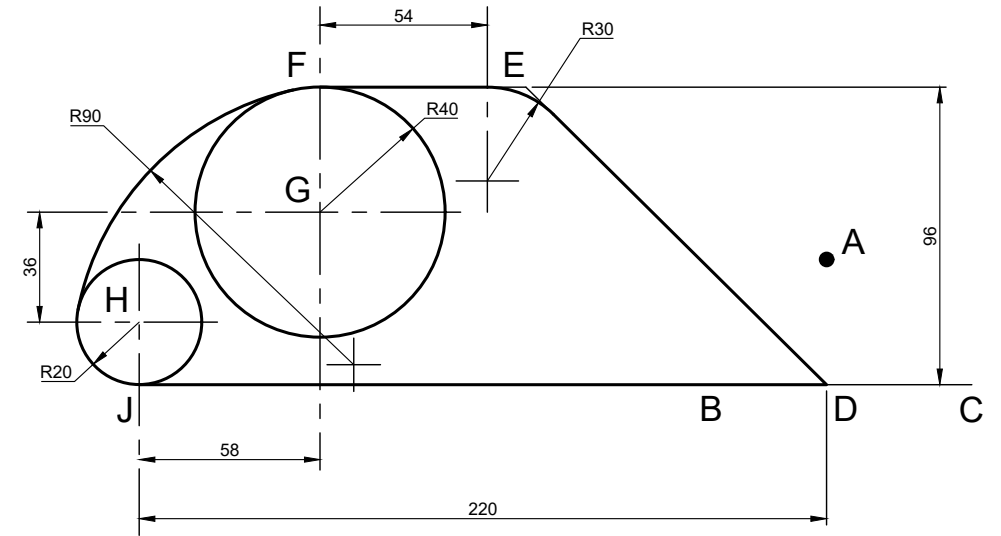

[40]

ASSESSMENT CRITERIA

Criteria	Mark	Score
1.1 Perpendicular A to BC (D)	✓1	6
1.2 Bisecting DE	✓2	6
1.3 Line EF	✓3	3
1.4 Circles G & H	✓4	6
1.5 Line DJ	✓5	3
1.6 Dividing line segment DJ (1/2)	6	6
1.7 Tangent circle to two lines (1/2)	7	3
1.8 External arc	✓8	7
TOTAL		40

CALCULATIONS

CIRCLE G	CIRCLE H
Tangent arc - Circle G	Tangent arc - Circle H
R90 - R40 ✓8	R90 - R20 ✓8
R50 ✓8	R70 ✓8