



# Principles of Mechanical Drawings - SECTIONING

Developed by: PC Viljoen  
Senior Educational Specialist for  
Engineering Graphics and Design  
Free State Province

# Mechanical Drawings

- Mechanical illustrations can be a simple **isometric drawing** to be drawn in **Third Angle Orthographic Projection (T.A.O.P.)** or the other way round.

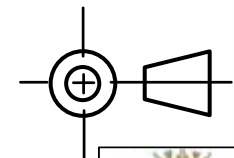
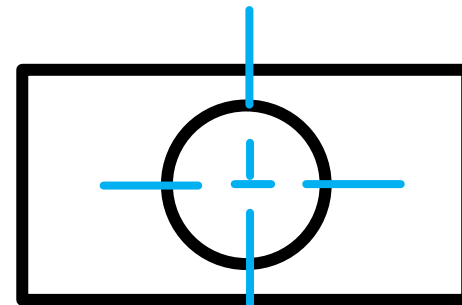
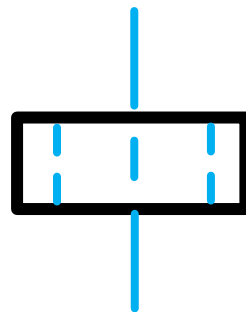
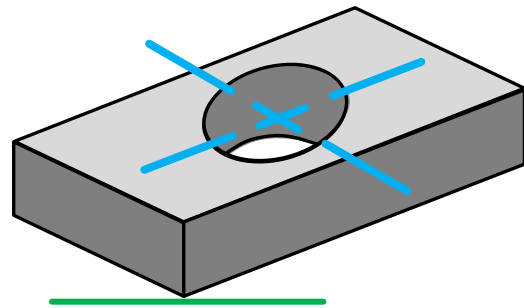

# Mechanical Drawings

- **Mechanical drawings** usually shows castings, parts or portions of mechanical components used in industry.

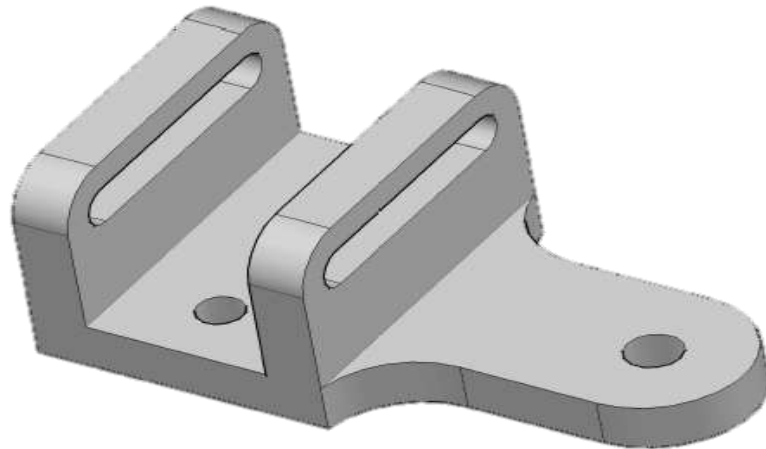

# Mechanical Drawings (assembled drawings)

- **Assembled drawings** is when mechanical components consisting of different machine parts are assembled as a unit.

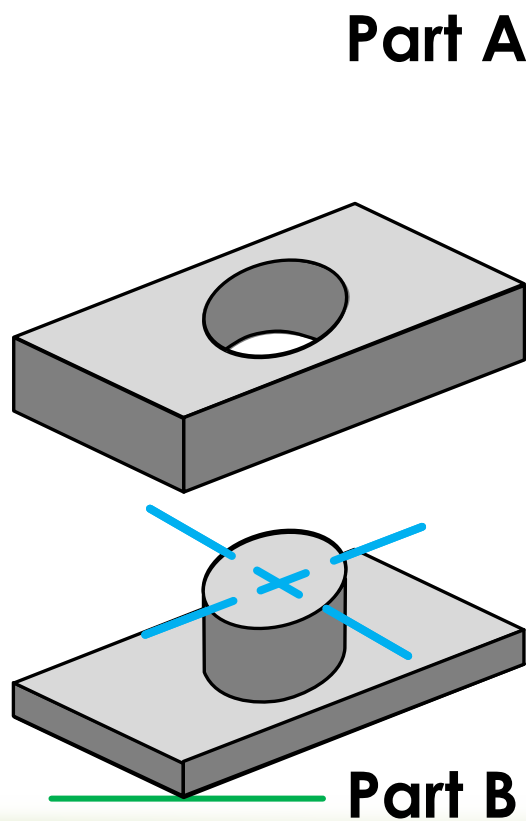

Part A

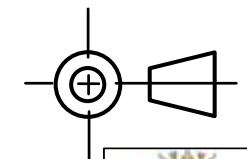
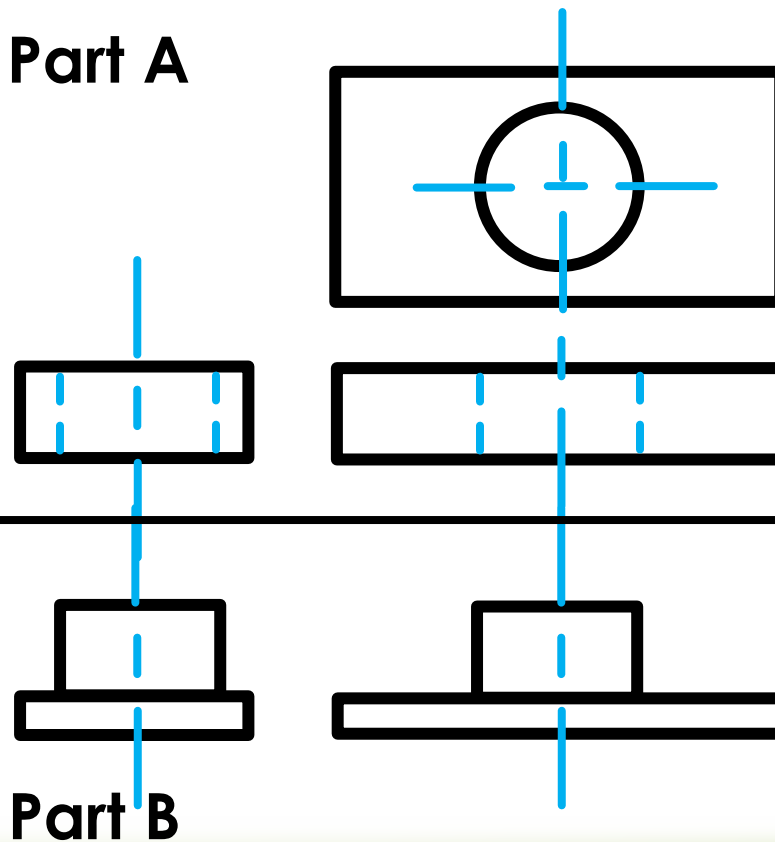

# Mechanical Drawings (sectioning)

- **Section drawings** is when mechanical components is cut to show the **inner detail**. The line indicating the point of sectioning is called the **cutting plane**.

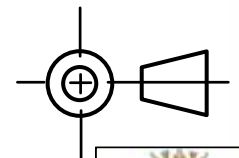
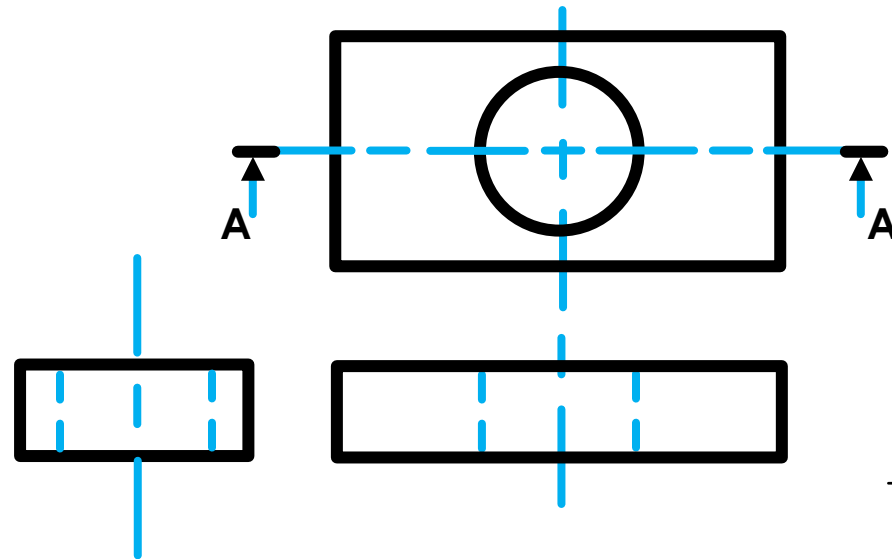
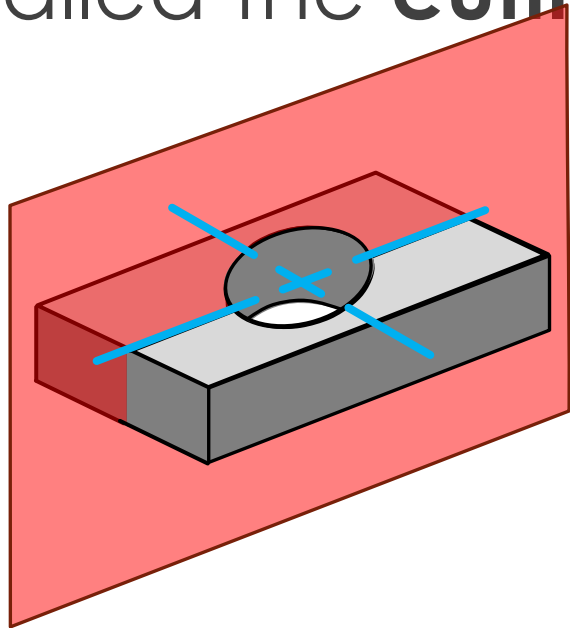

# Mechanical Drawings (sectioning)

- All solid components that are cut by a cutting plane must be **hatched** with B-type lines (medium line).

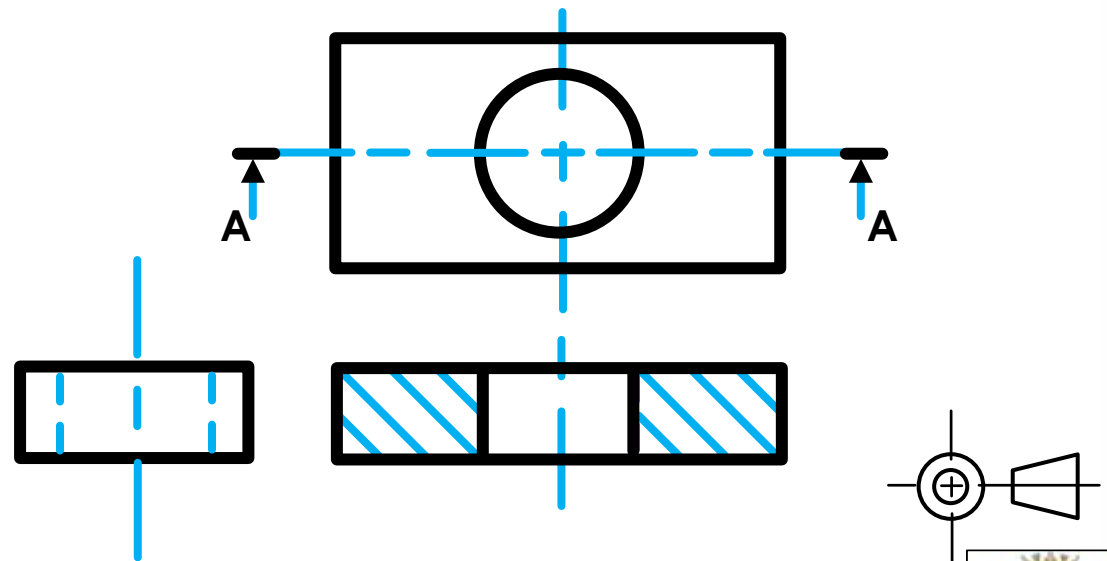
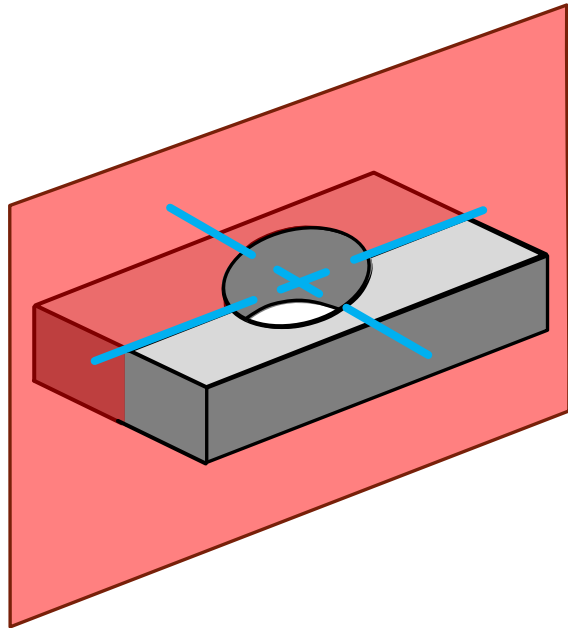

# Mechanical Drawings (sectioning)

- ➔ **Hatching** will always be with **B-type lines (medium line)** which appear  $\pm 5$  mm apart from each other drawn on  $45^\circ$ .

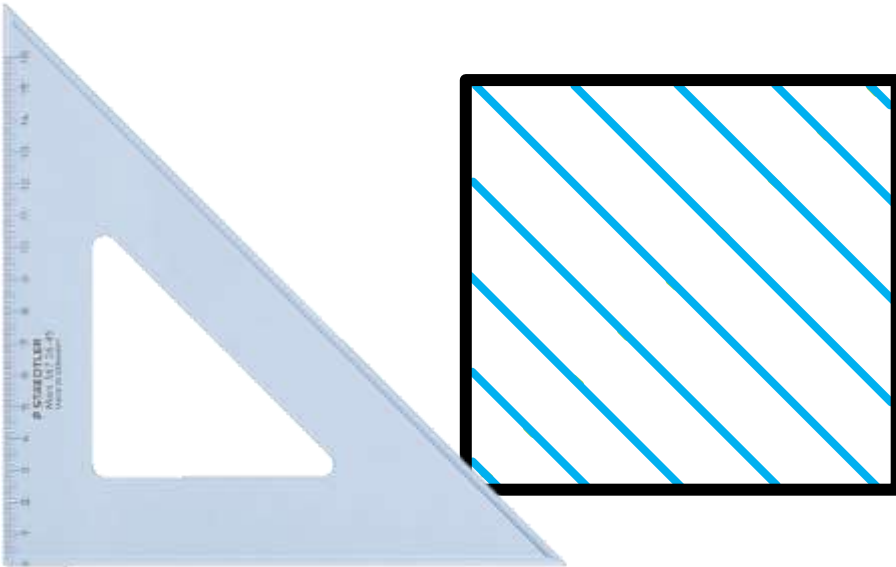

# Mechanical Drawings (sectioning)

- The **cutting plane** must be clearly shown on all sectioned drawings.

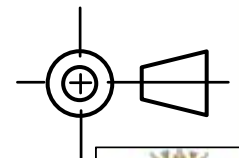
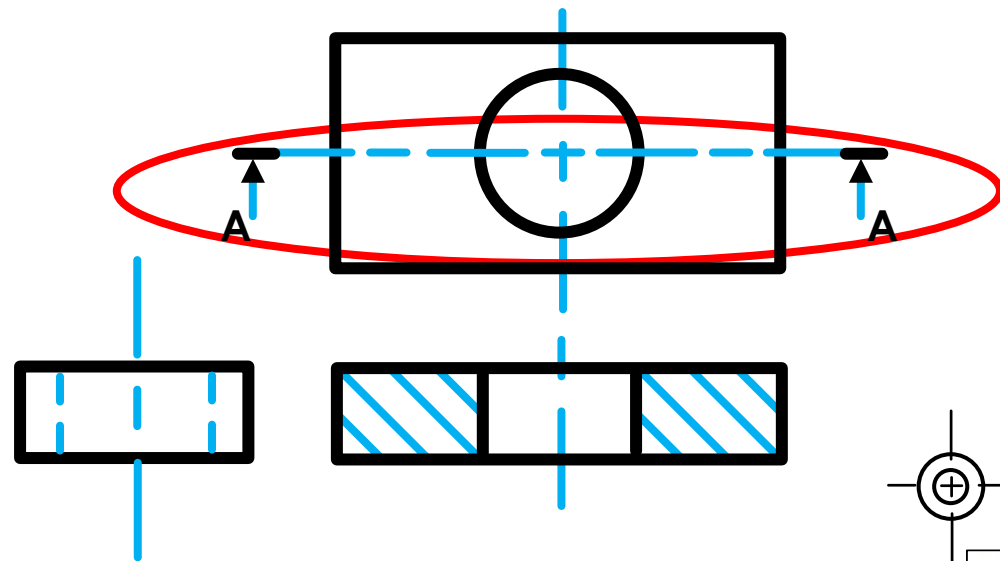
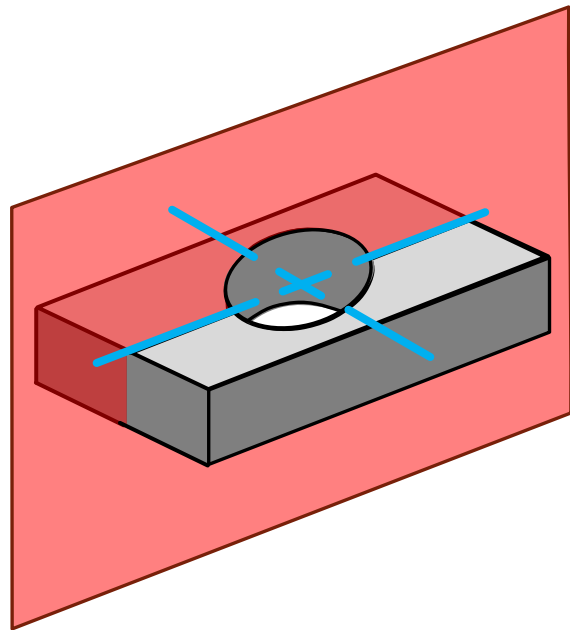

# Mechanical Drawings (sectioning)

- ➔ In T.A.O.P. the **cutting plane** is shown in **medium chain-lines** (B-type) of  $\pm 20$  mm line,  $\pm 4$  mm gap and  $\pm 4$  mm line.

T.A.O.P. = Third-  
Angle Orthographic  
Projection



# Mechanical Drawings (sectioning)

- ➔ Medium chain lines will always **start & end with a long line.**



# Mechanical Drawings (sectioning)

- ➔ In **F.A.O.P.** the **cutting plane** is shown as a **solid line**

F.A.O.P. = First-Angle  
Orthographic  
Projection

# Mechanical Drawings (sectioning)

- ➔ The cutting plane line must be **emphasised** at both **ends**.

F.A.O.P. = First-Angle Orthographic Projection

T.A.O.P. = Third-Angle Orthographic Projection



# Mechanical Drawings (sectioning)

- ➔ The **arrows** of the cutting plane is larger than dimension arrows.

F.A.O.P. = First-Angle Orthographic Projection

T.A.O.P. = Third-Angle Orthographic Projection



# Mechanical Drawings (sectioning)

- ➔ The **tail** part of the arrows must be B type line quality.

F.A.O.P. = First-Angle Orthographic Projection

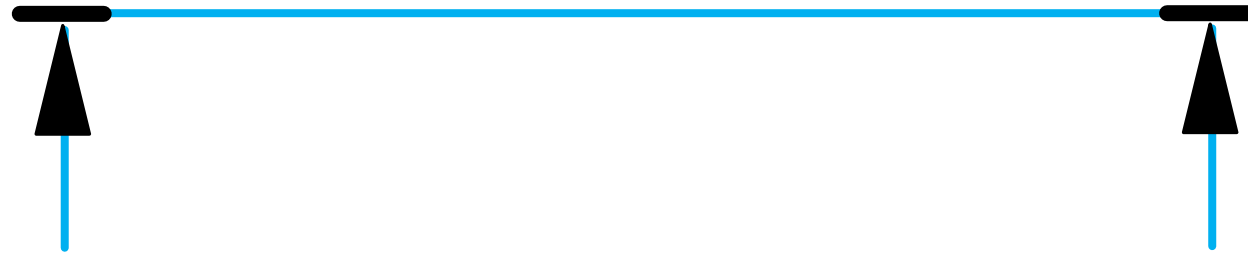

T.A.O.P. = Third-Angle Orthographic Projection

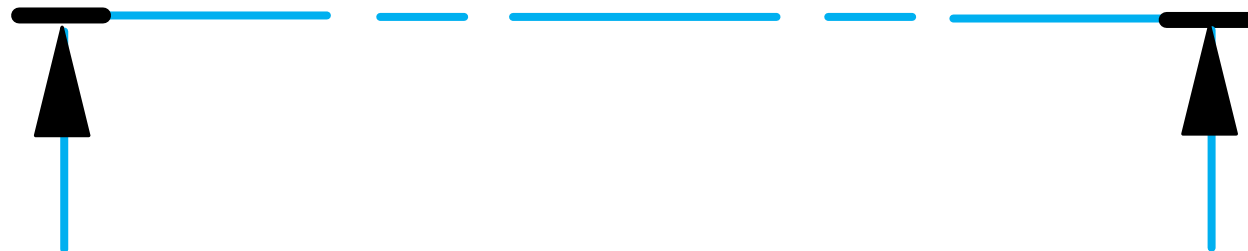

# Mechanical Drawings (sectioning)

- ➔ The **arrows** on the cutting plane will **point** towards the **remaining portion** of the object.

F.A.O.P. = First-Angle Orthographic Projection



T.A.O.P. = Third-Angle Orthographic Projection



# Mechanical Drawings (sectioning)

- ➔ The cutting plane will normally be **named** after letters of the alphabet (e.g. AA).

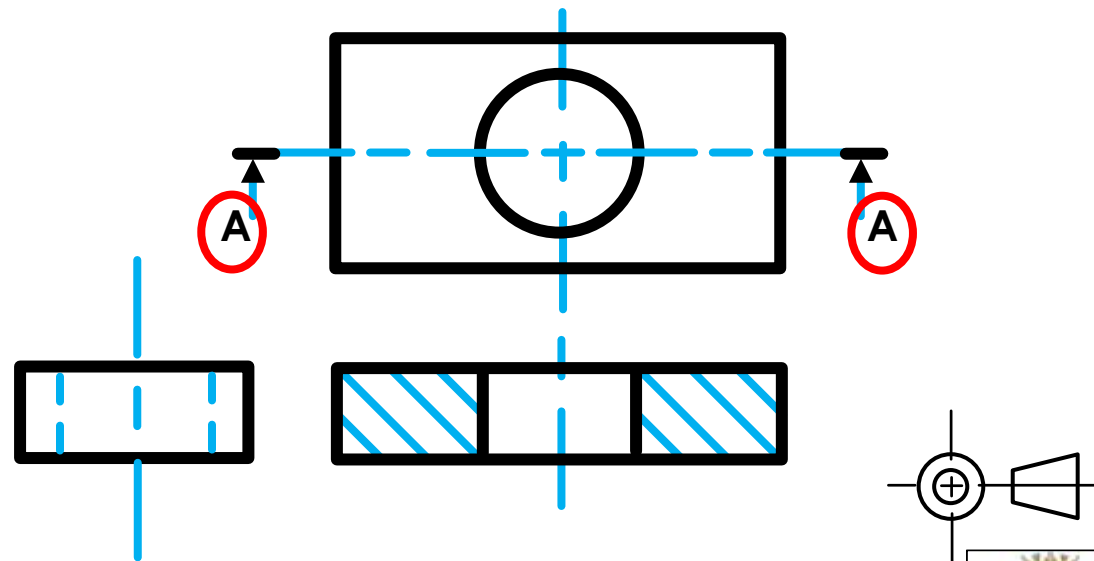
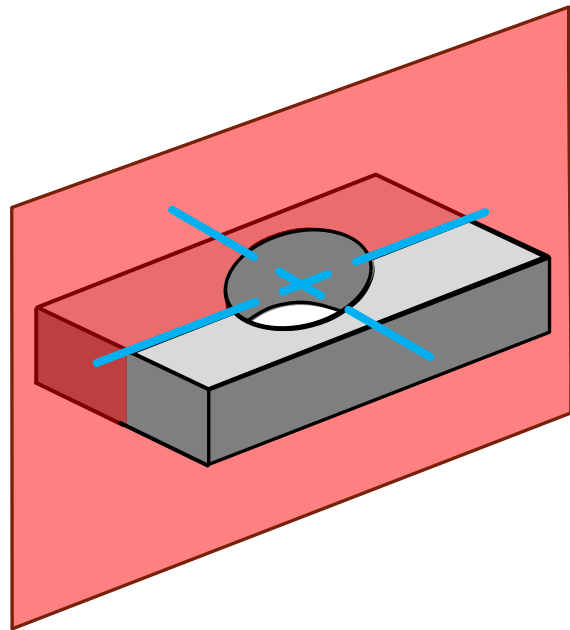

# Mechanical Drawings (sectioning)

- ➔ The view which is cut (sectioned) because of the cutting plane (e.g. AA) will be named after the cutting plane: e.g. **SECTIONED FRONT VIEW ON AA**

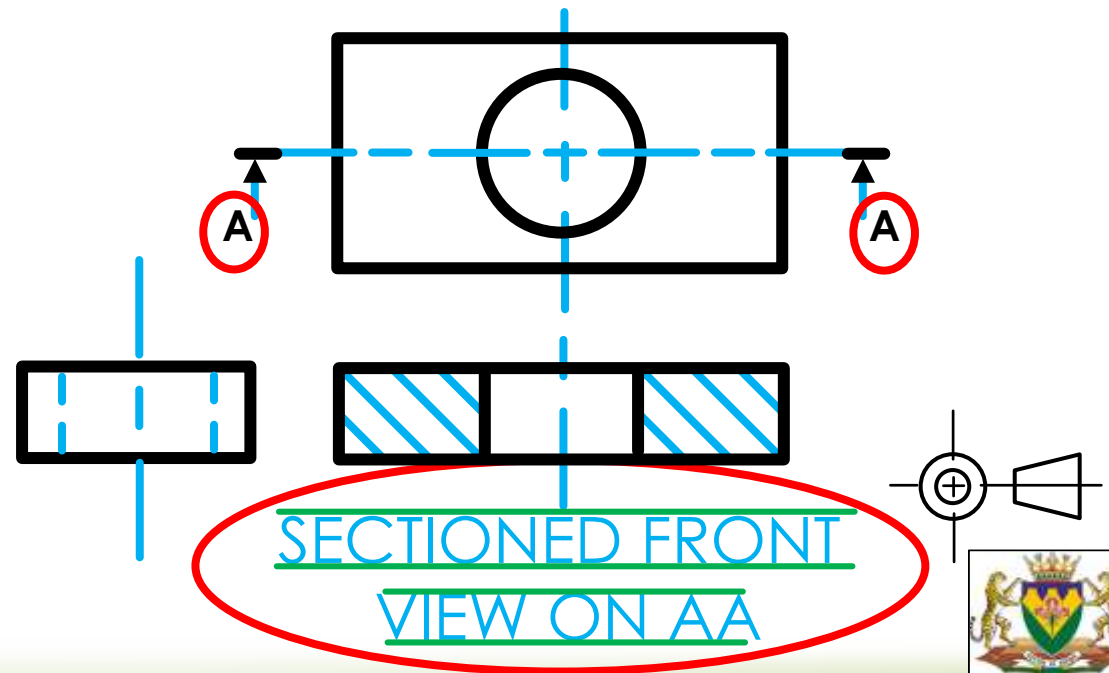
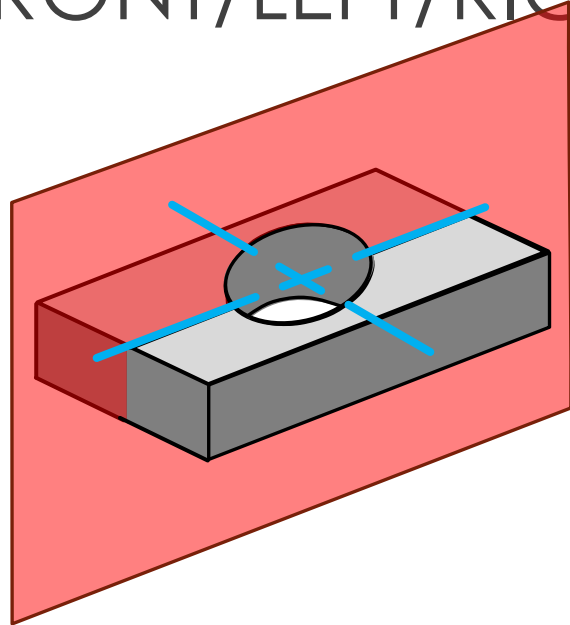

# Mechanical Drawings (sectioning)

- ➔ The **cutting plane** can also **bend** to show a half sectioned area.

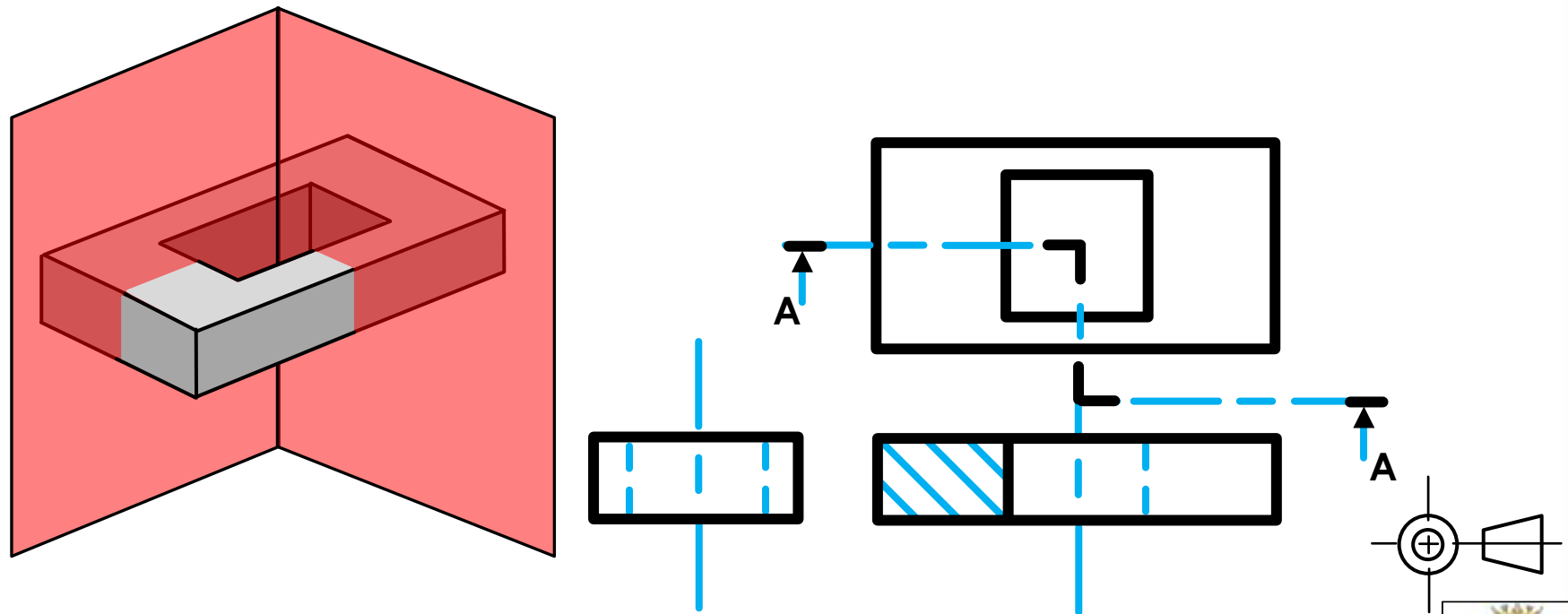

# Mechanical Drawings (sectioning)

- ➔ The **cutting plane** must be **emphasised** at all **bends and ends**.

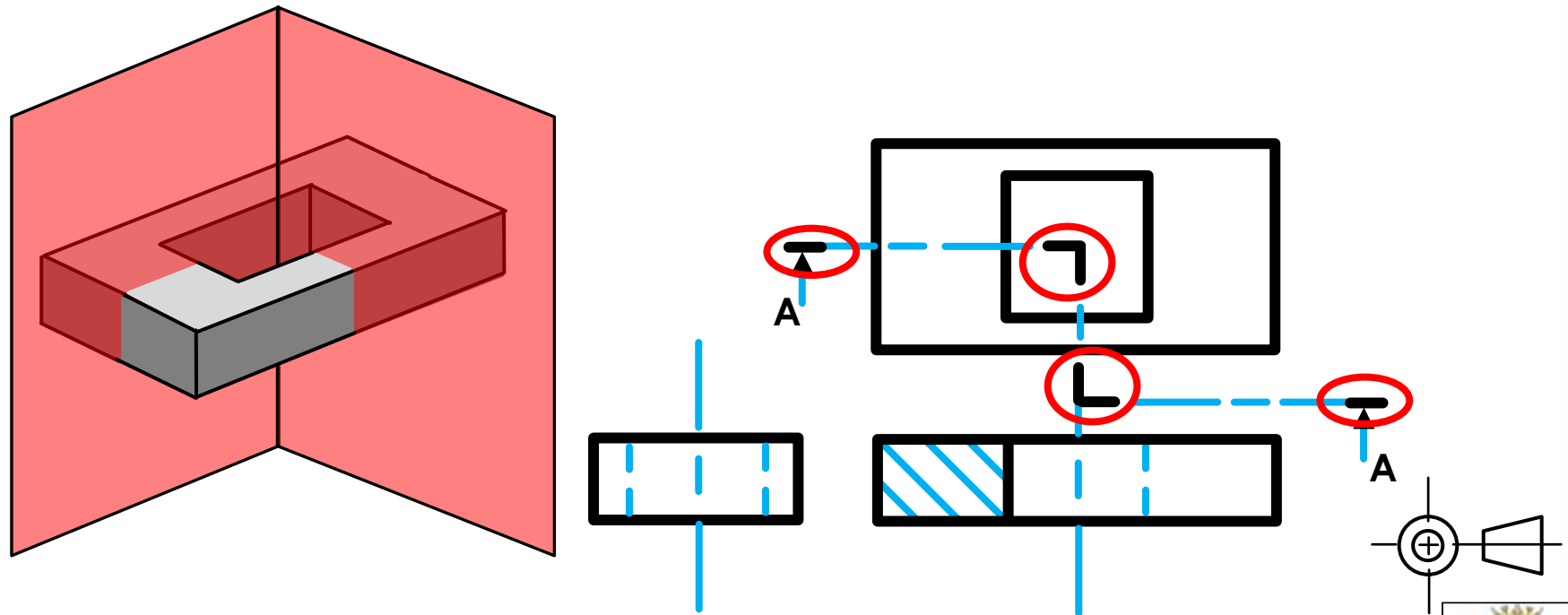

# Mechanical Drawings (sectioning)

- When the sectioned half of the view contains a **hollow area** towards the centre point, a **centre line** should be indicated.

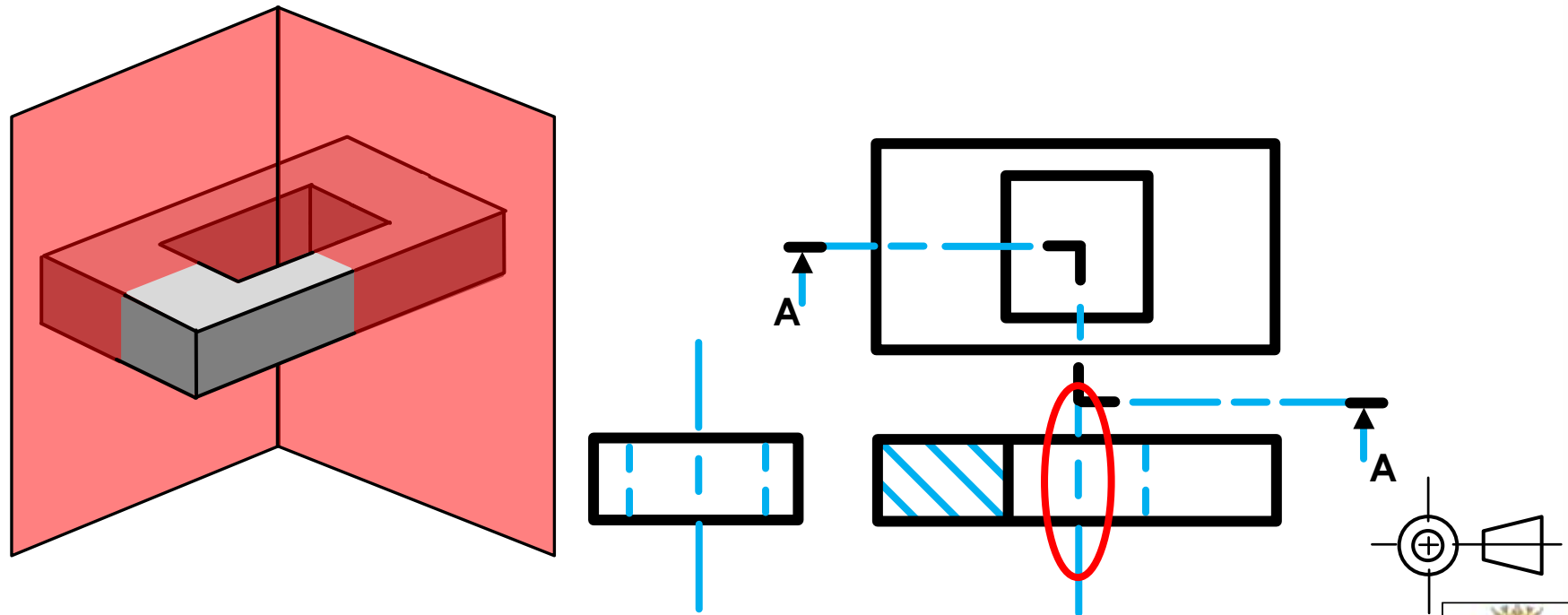

# Mechanical Drawings (sectioning)

- When the sectioned half of the view contains **a solid area** towards the centre point, the centre line should be **changed to a continuous** thin line.

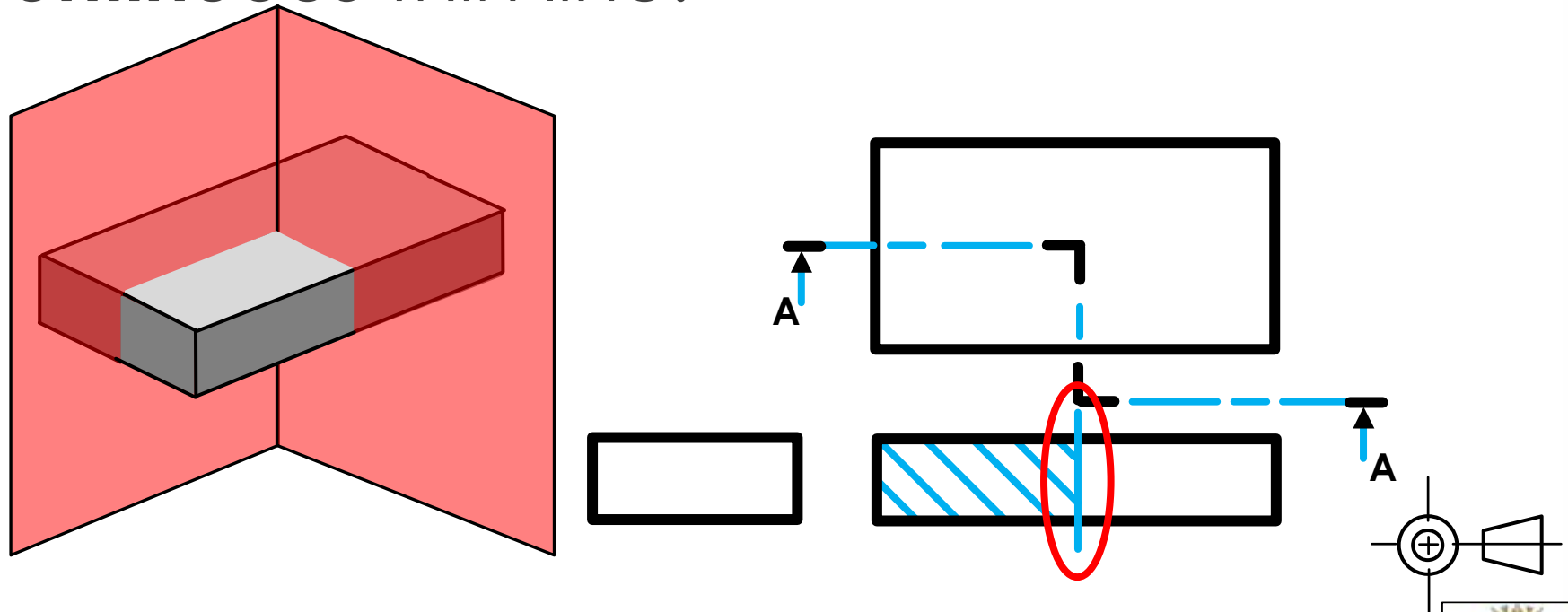

# Mechanical Drawings (sectioning)

- ➔ If the **sectioned object appear predominantly vertical**, all hatching lines will be diagonal in  $45^\circ$  B-type lines (medium line).

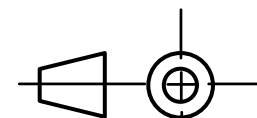
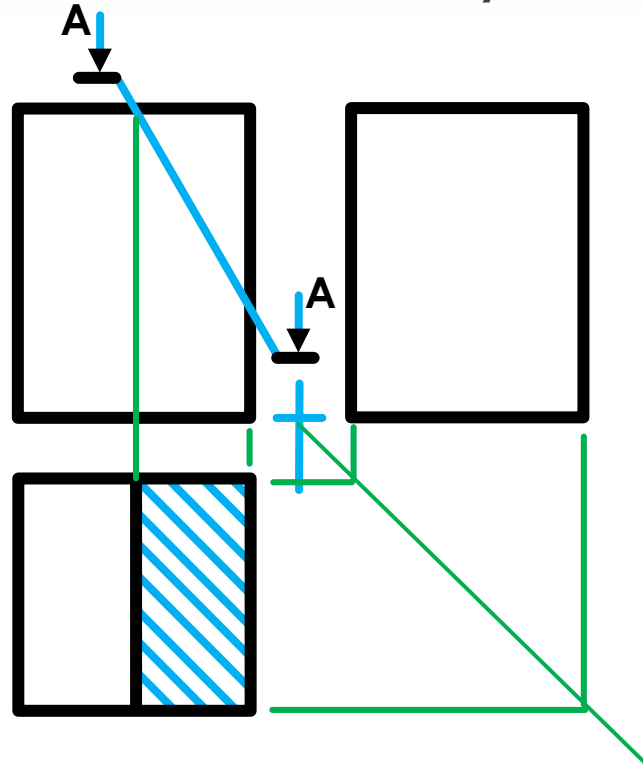

# Mechanical Drawings (sectioning)

- Should a **sectioned object appear predominantly diagonal**, all hatching lines will be either horizontal ( $0^\circ$ ) or vertical ( $90^\circ$ ).

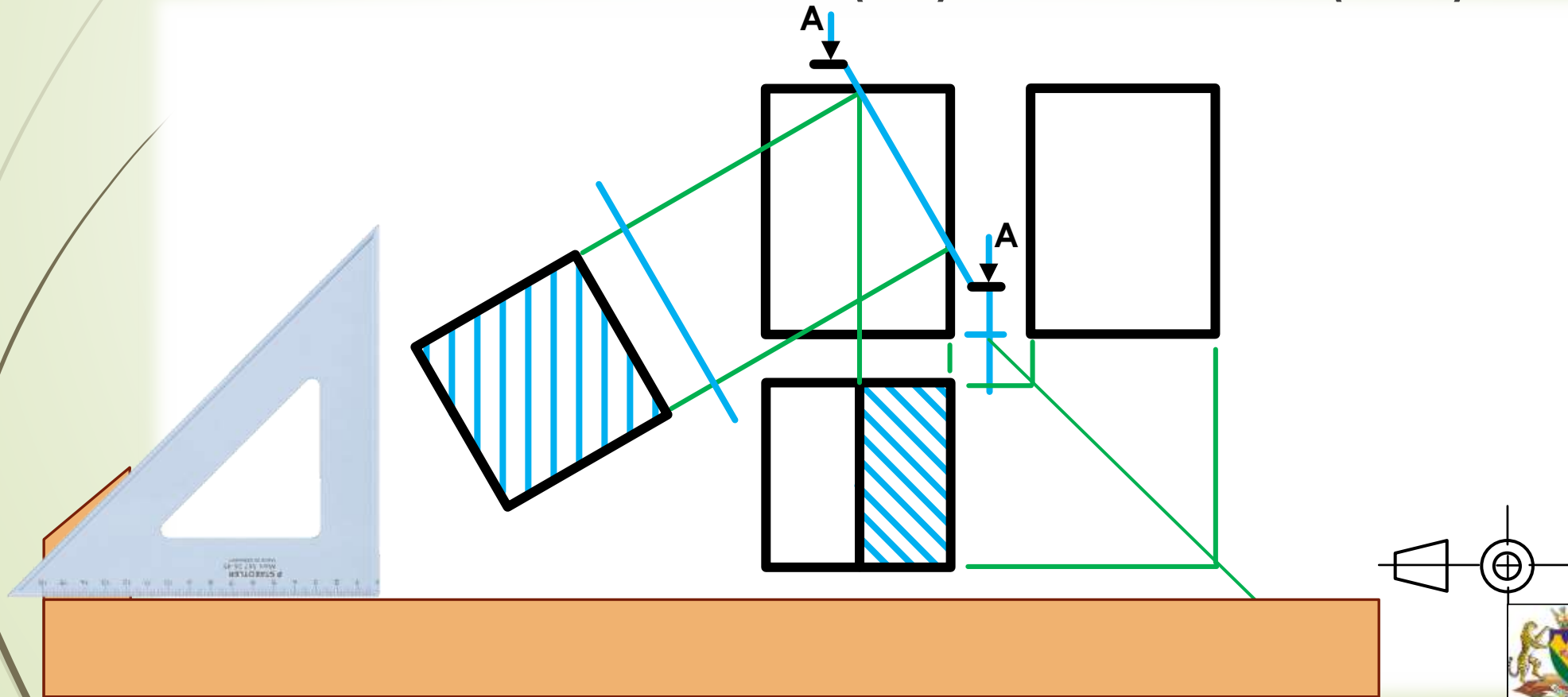

# Mechanical Drawings (sectioning)

- Should a **sectioned object appear predominantly diagonal**, all hatching lines will be either horizontal ( $0^\circ$ ) or vertical ( $90^\circ$ ).

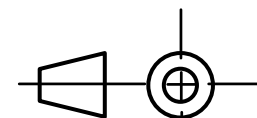
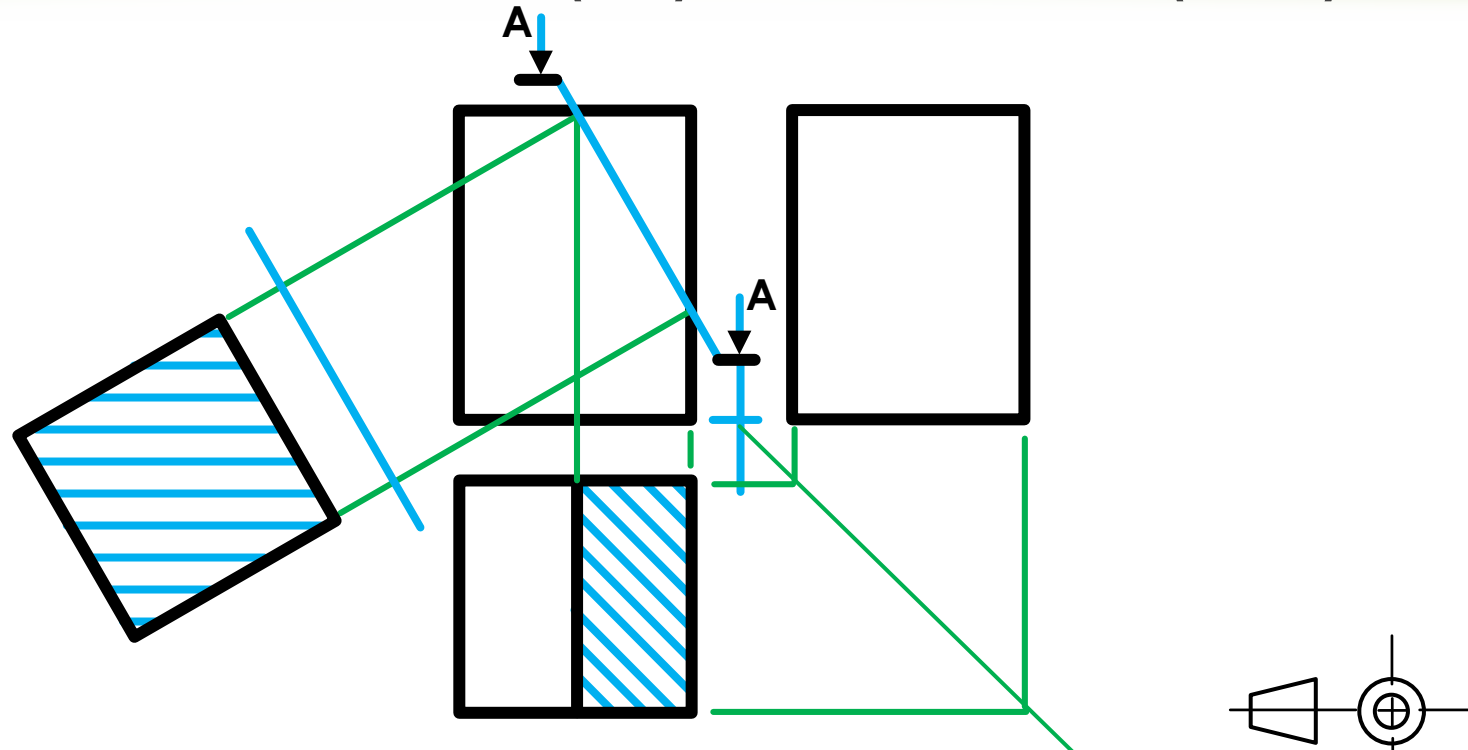

# Mechanical Drawings (sectioning)

- **Hatch lines of two components** next to each other must alternate in direction to indicate the difference in components.

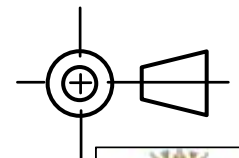
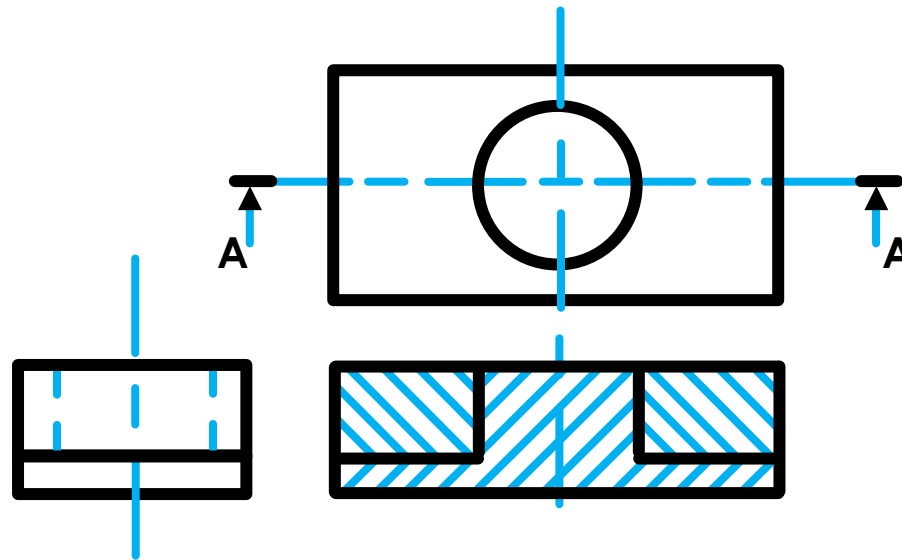
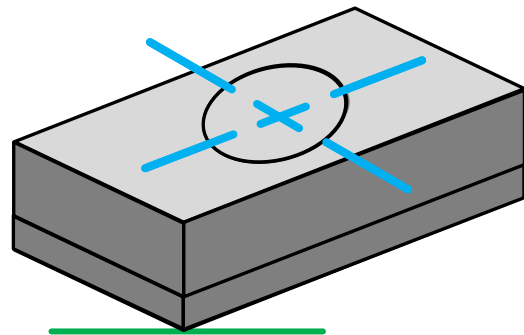

# Mechanical Drawings (sectioning)

- ➔ **Hatch lines of three components** next to each other must alternate in direction while the hatch lines of the smallest component can be drawn to a smaller distance apart from each other.

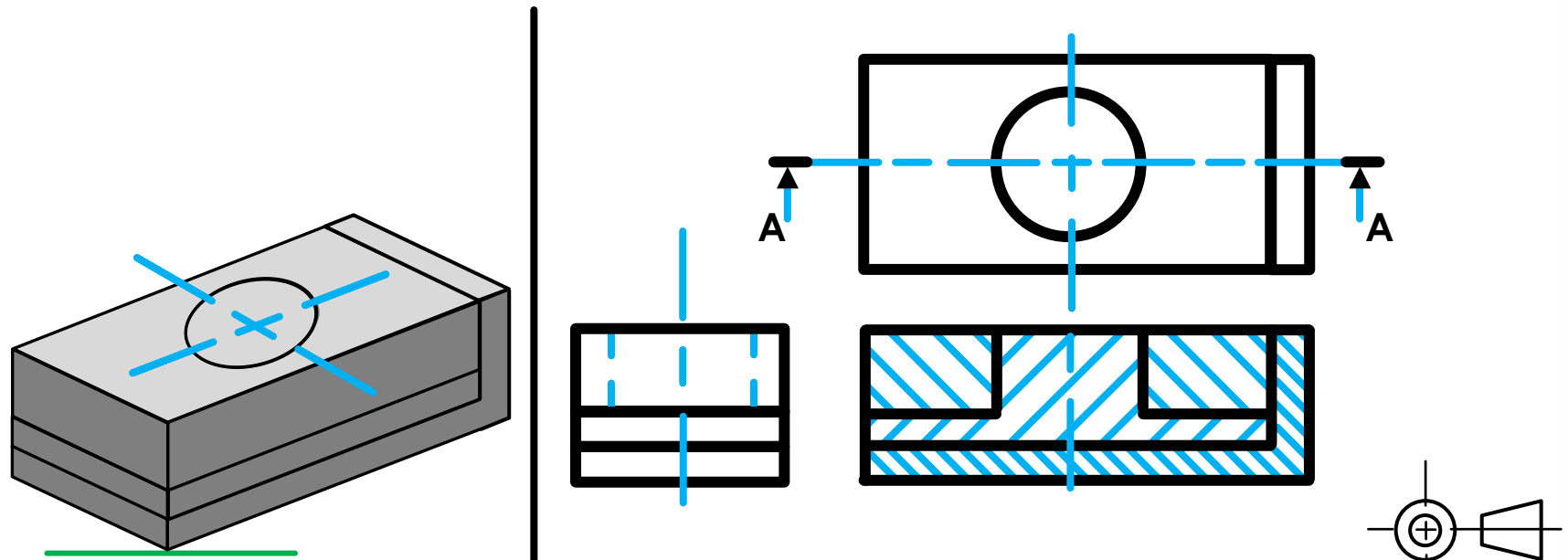

# Mechanical Drawings (sectioning)

- ➔ A **reinforced rib** may be sectioned, but **NO** hatching must be shown when the cutting plane passes longitudinally through it.

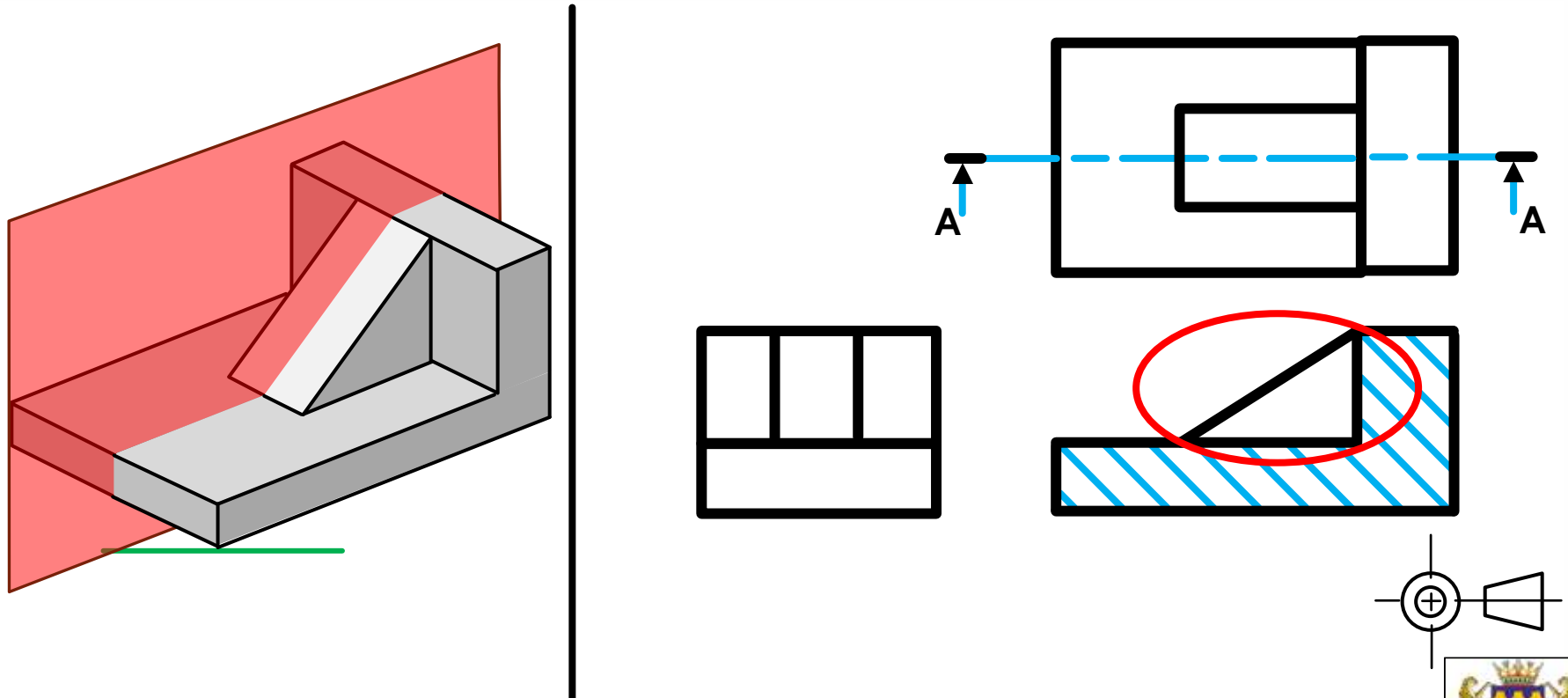

# Mechanical Drawings (sectioning)

- **Ribs** may **not** be sectioned when the cutting plane passes longitudinally through them.

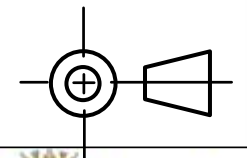
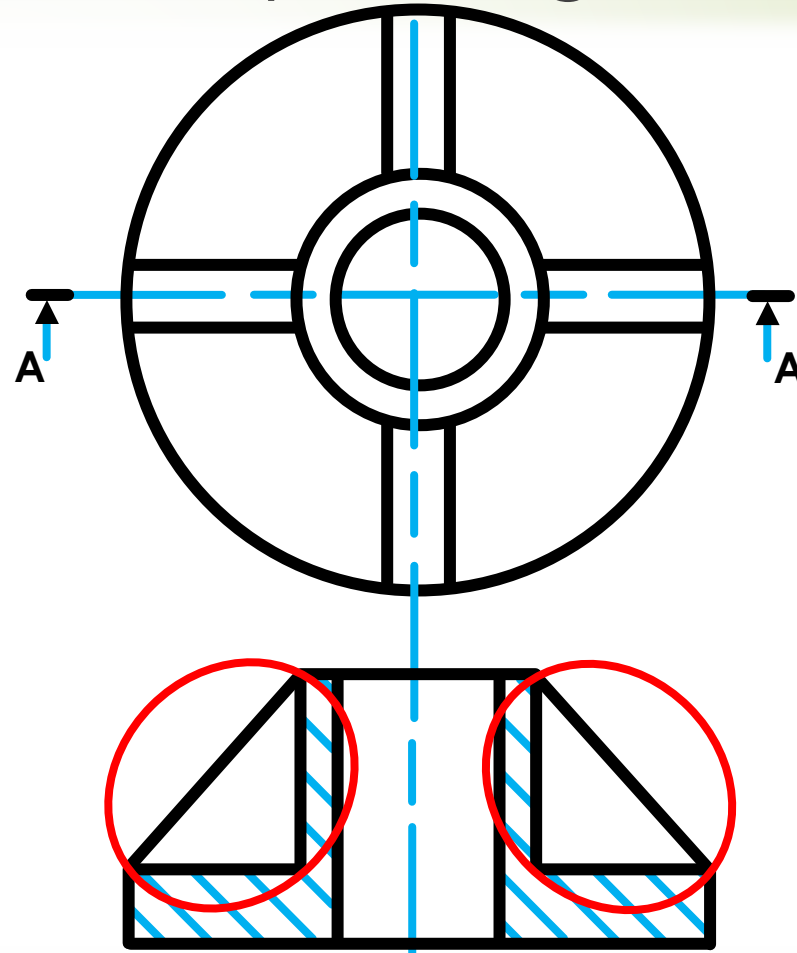
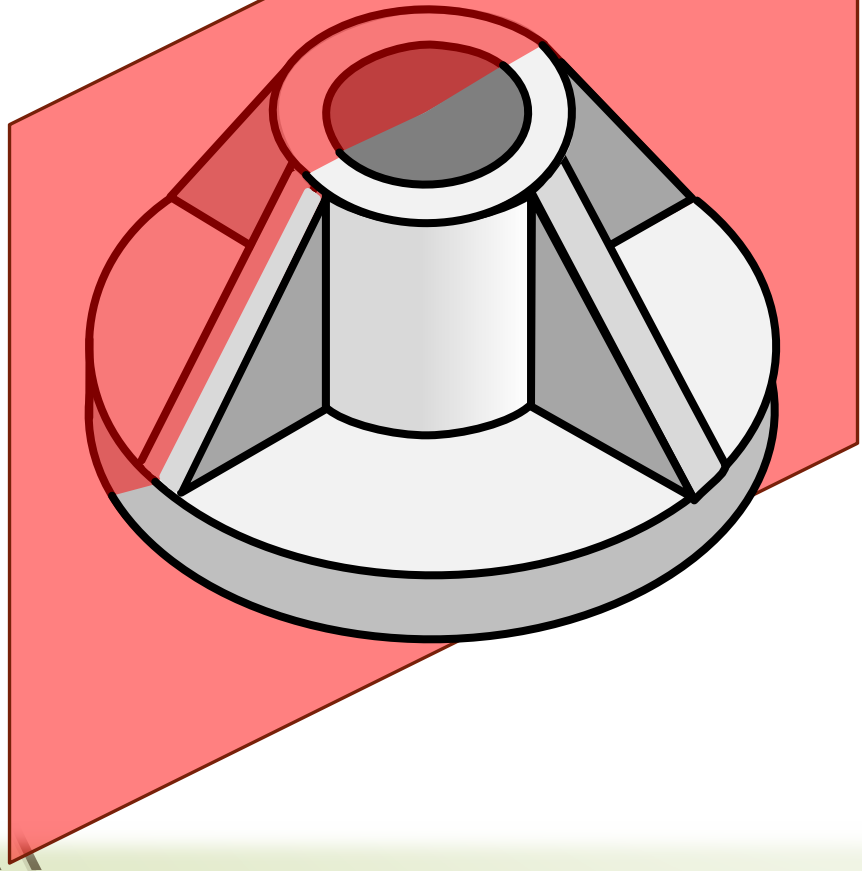

# Mechanical Drawings (sectioning)

- **Solid areas** must be sectioned when the cutting plane passes longitudinally through it.

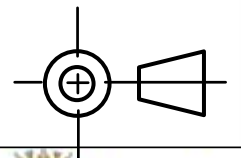
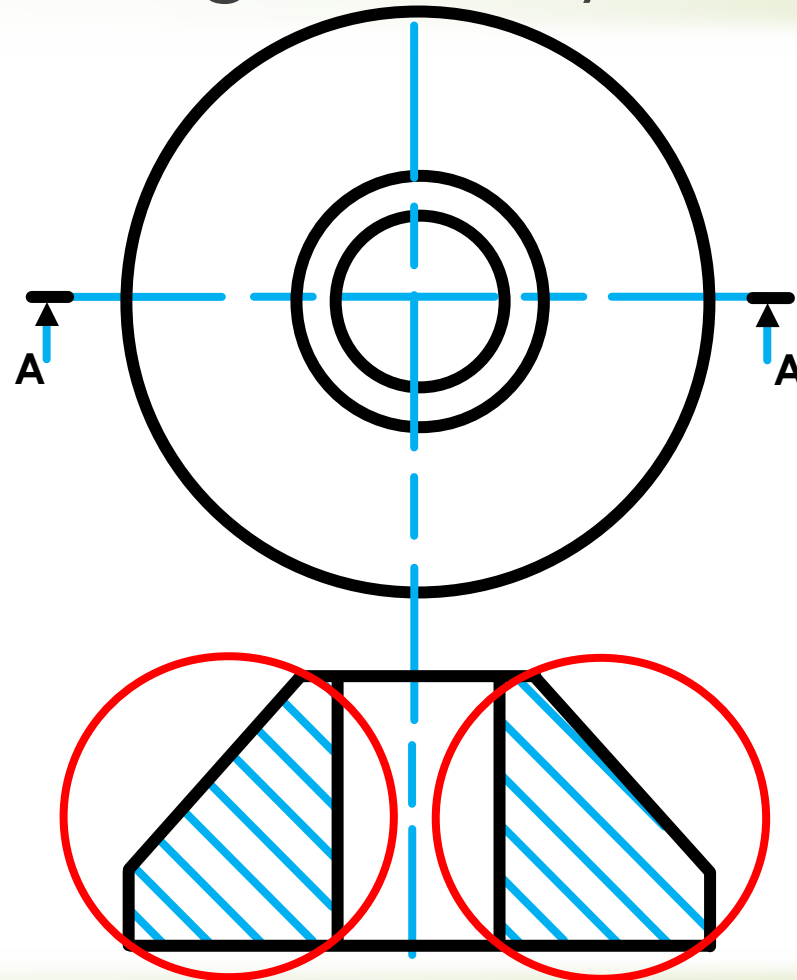
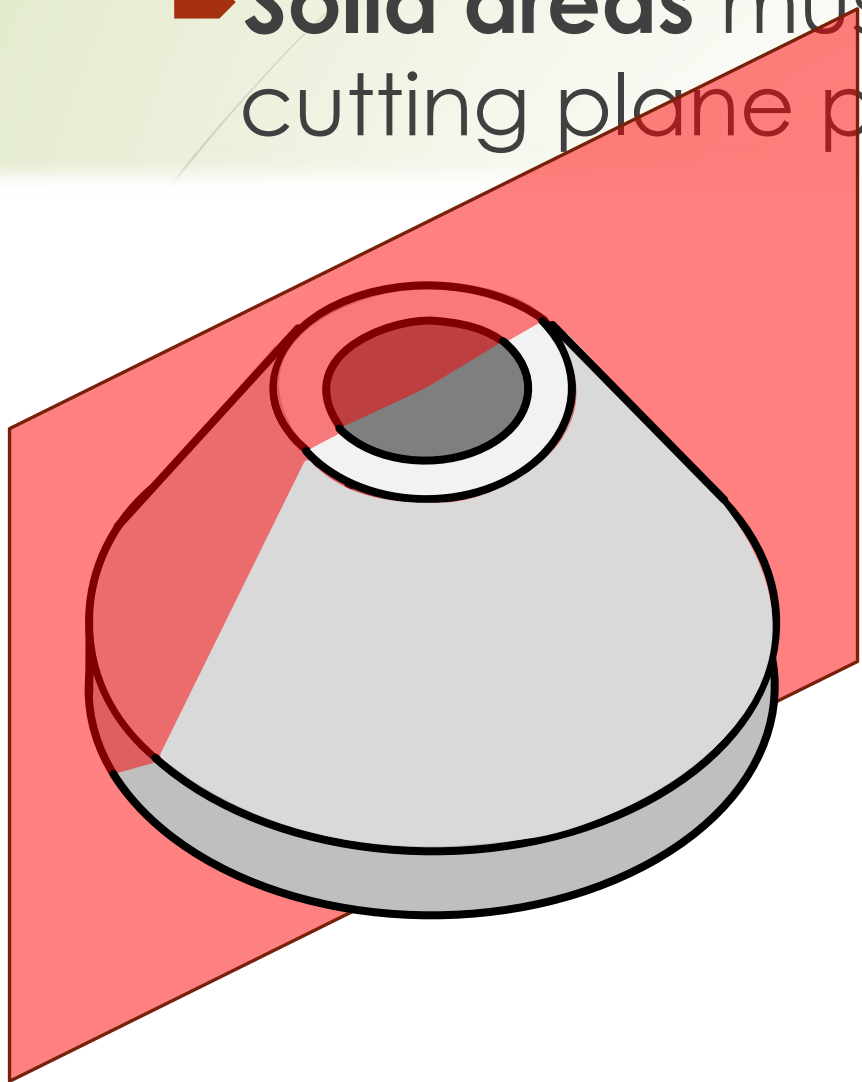

# Mechanical Drawings (sectioning)

- Hatching of an internal hole.

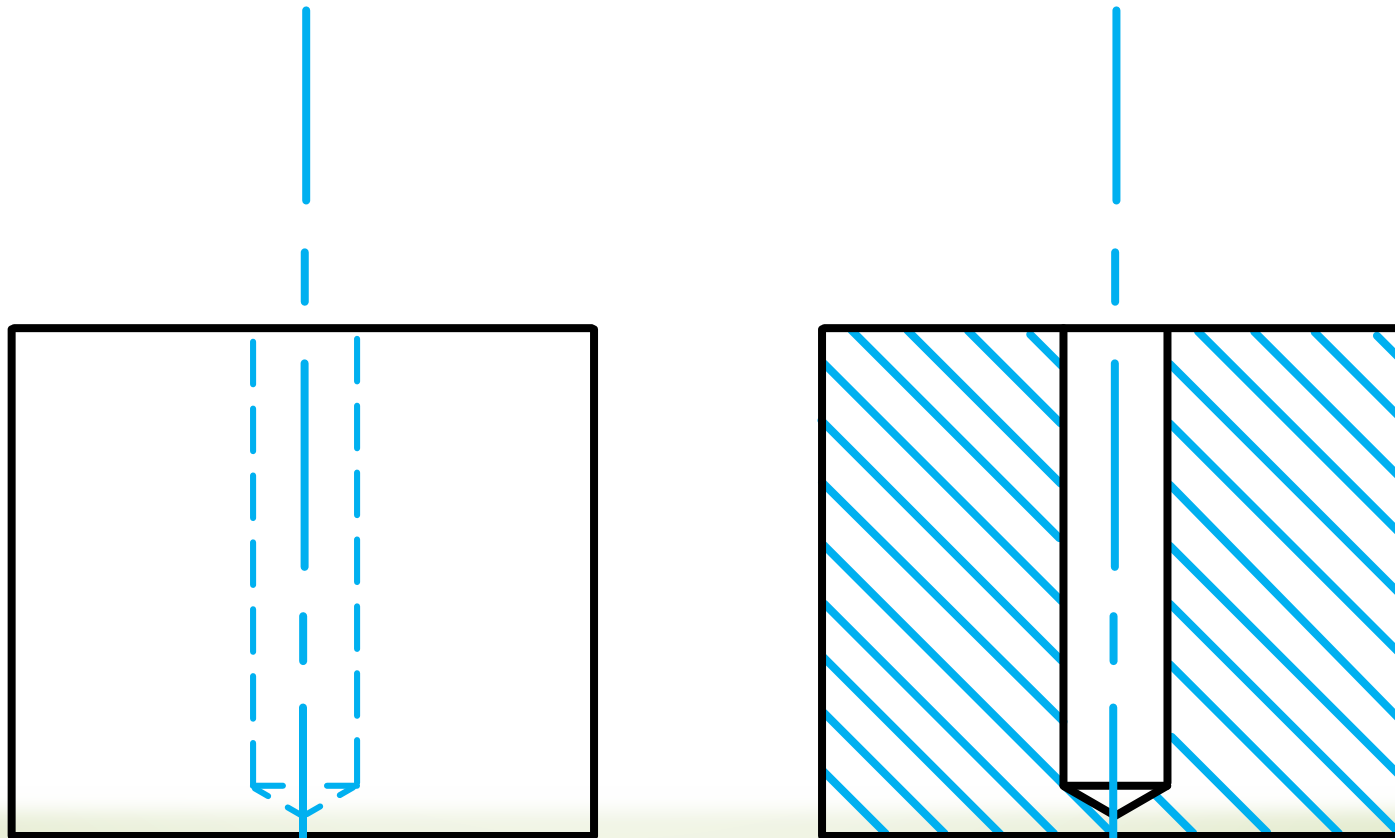

# Mechanical Drawings (sectioning and hidden detail)

- ➔ **Hidden detail** should also be shown **behind hatching** when **necessary for clarity**.

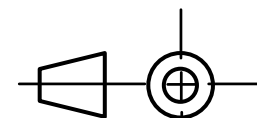
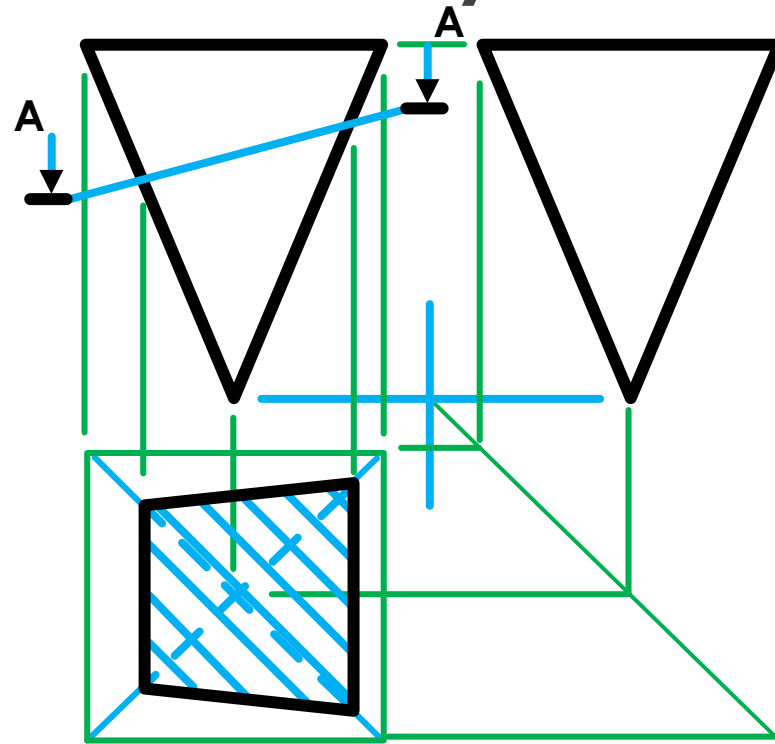
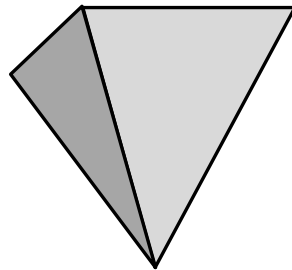

# Mechanical Drawings (sectioning)

- ➔ Hatching may be interrupted for dimensions and lettering.

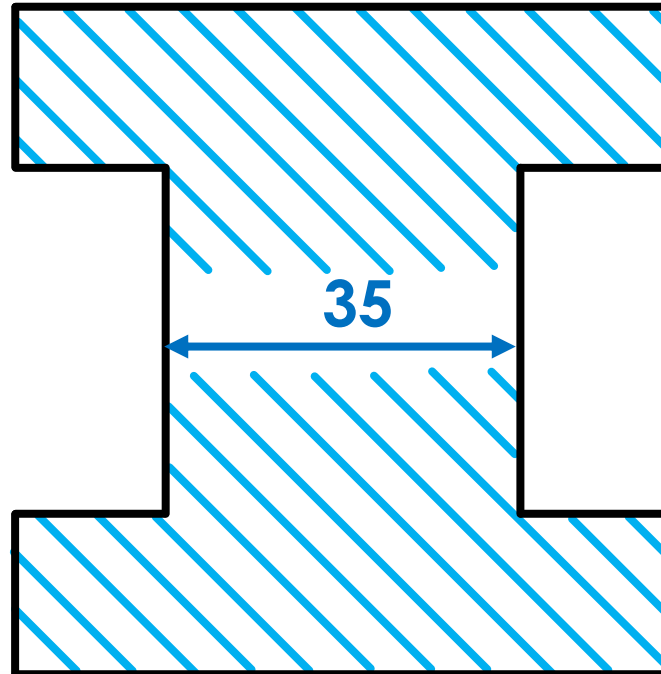

# Mechanical Drawings (sectioning)

- ➔ In the case of a large area, the hatching may be limited to a zone following the outline of the area

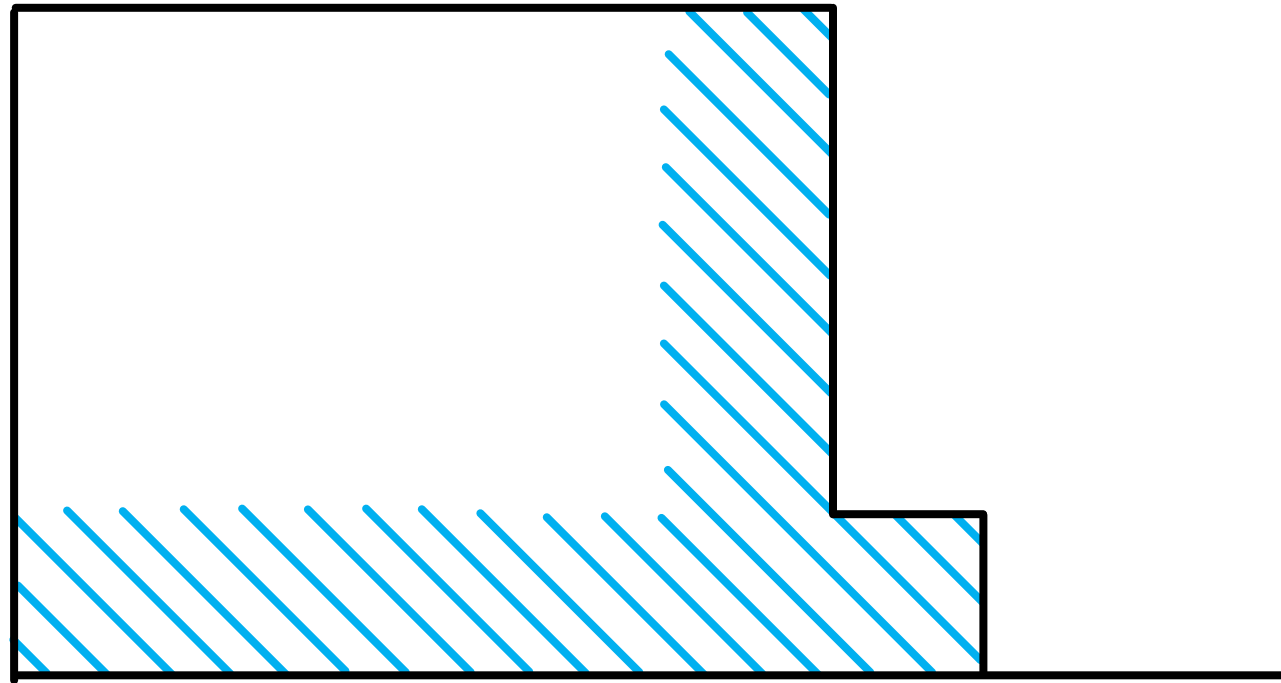

# Mechanical Drawings (sectioning)

- Indication of a bearing.

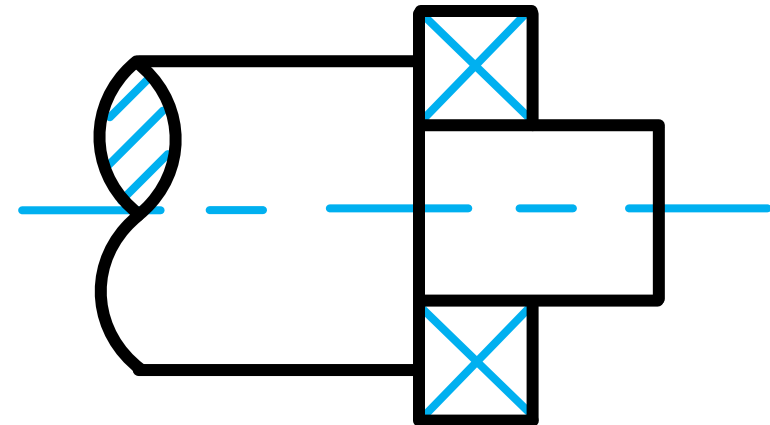
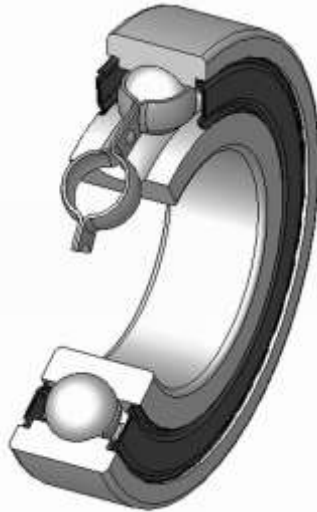

# Mechanical Drawings (sectioning)

- ➔ A view may be drawn in **part section** to show detail that would otherwise be hidden

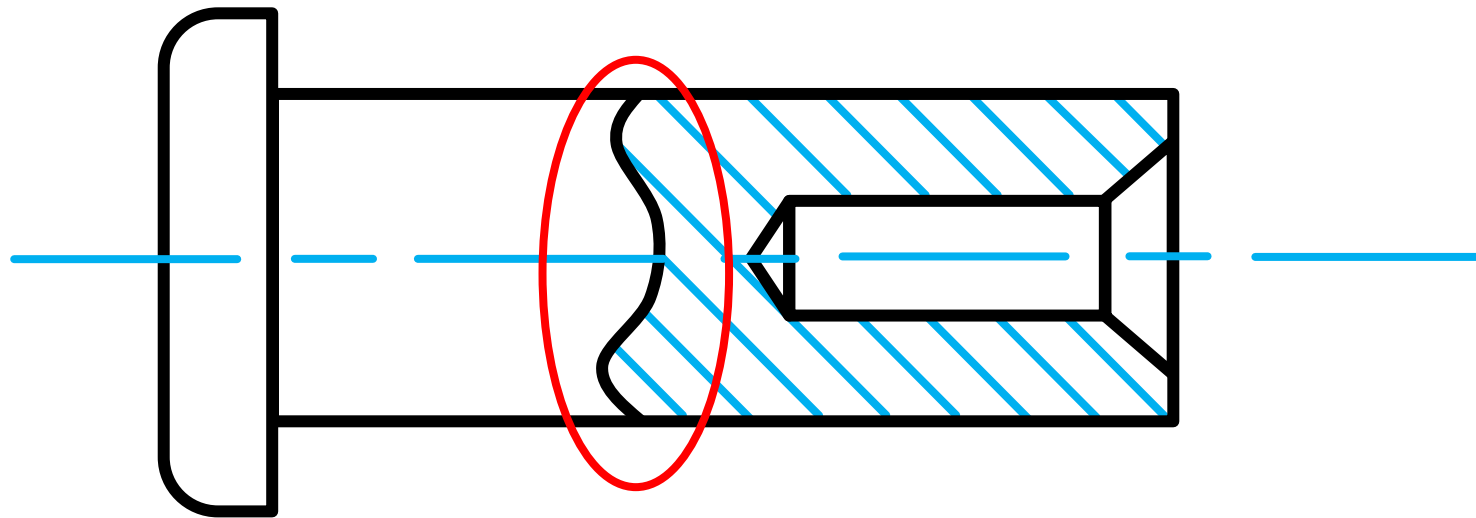

# Mechanical Drawings (sectioning)

- A **revolved section** is used to show the **shape** of a cross-section by revolving the cutting plane in position.

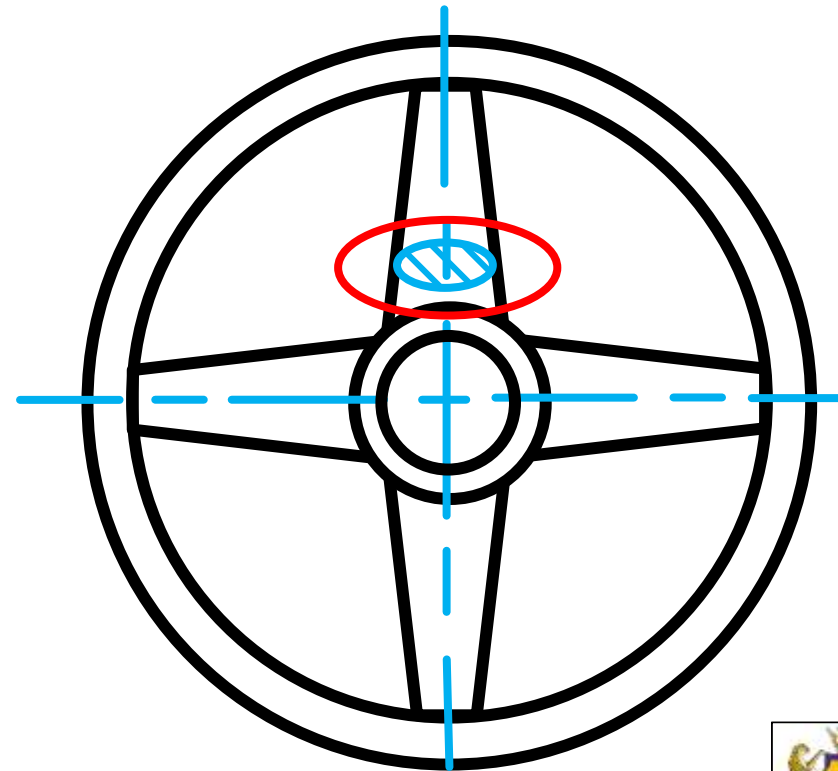
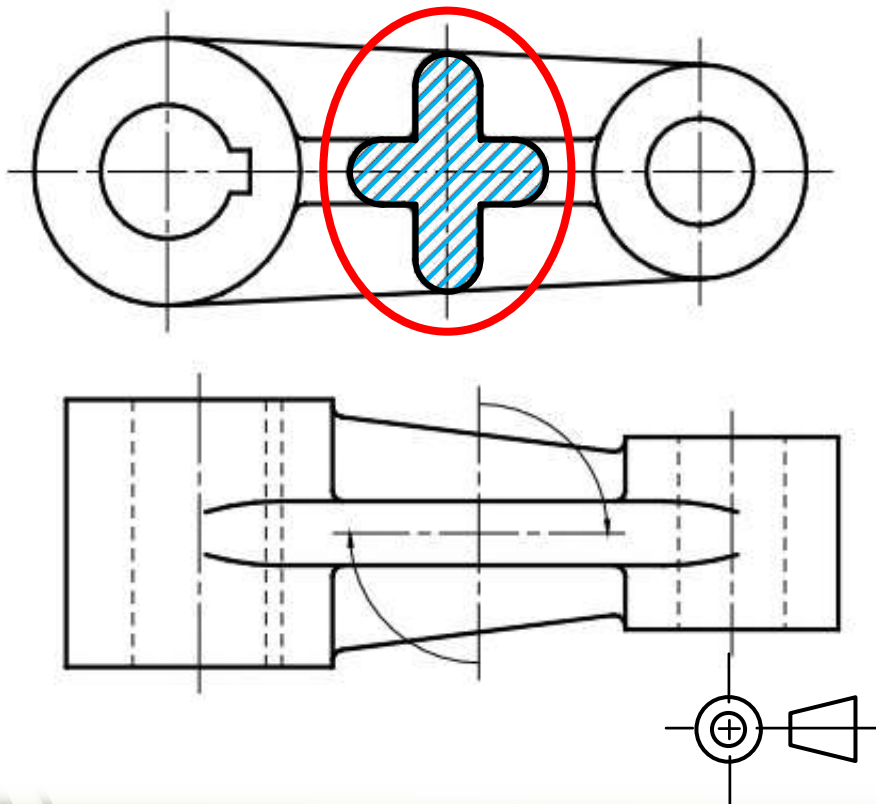

# Mechanical Drawings (sectioning)

- A **removed section** show the **shape** of the cross-section placed near the view and, if applicable, connected with the view by its line of symmetry (thin chain line) through the cutting plane.

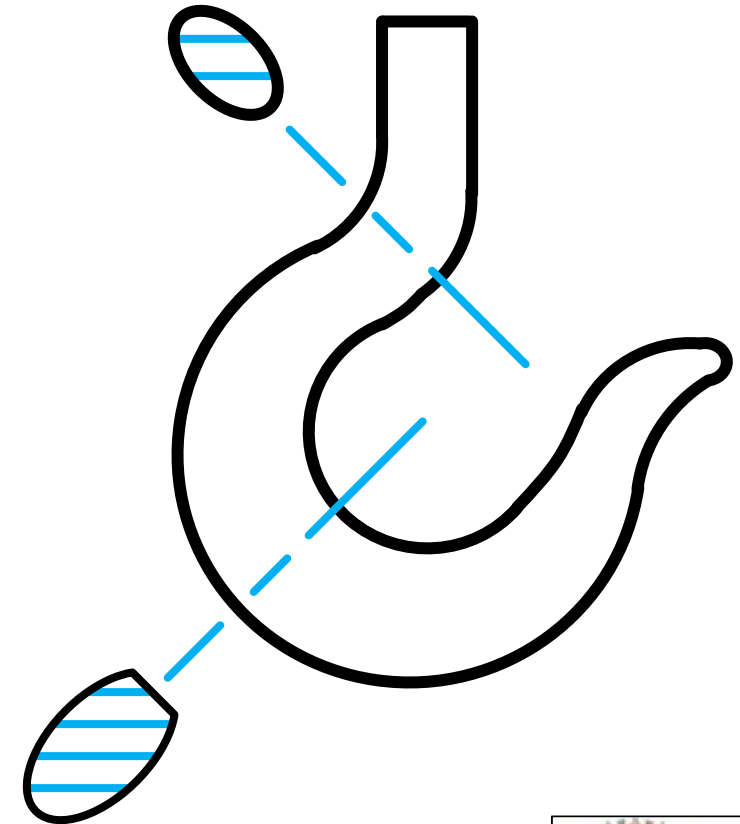

# Mechanical Drawings (sectioning)

- Sections of components that are **too thin** for hatching may be blackened (i.e. filled in solid), and a space left between adjacent components.

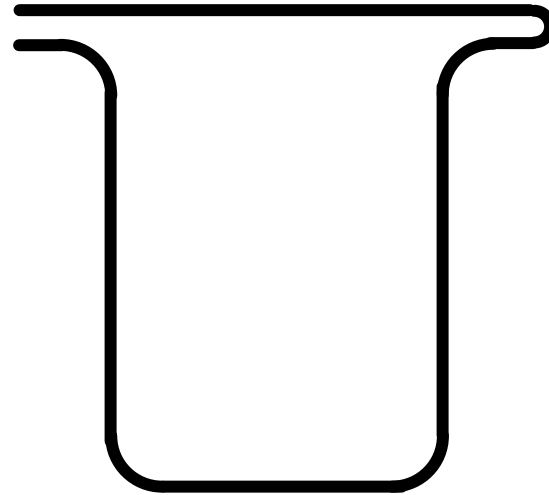

# Mechanical Drawings (sectioning)

## Successive sections

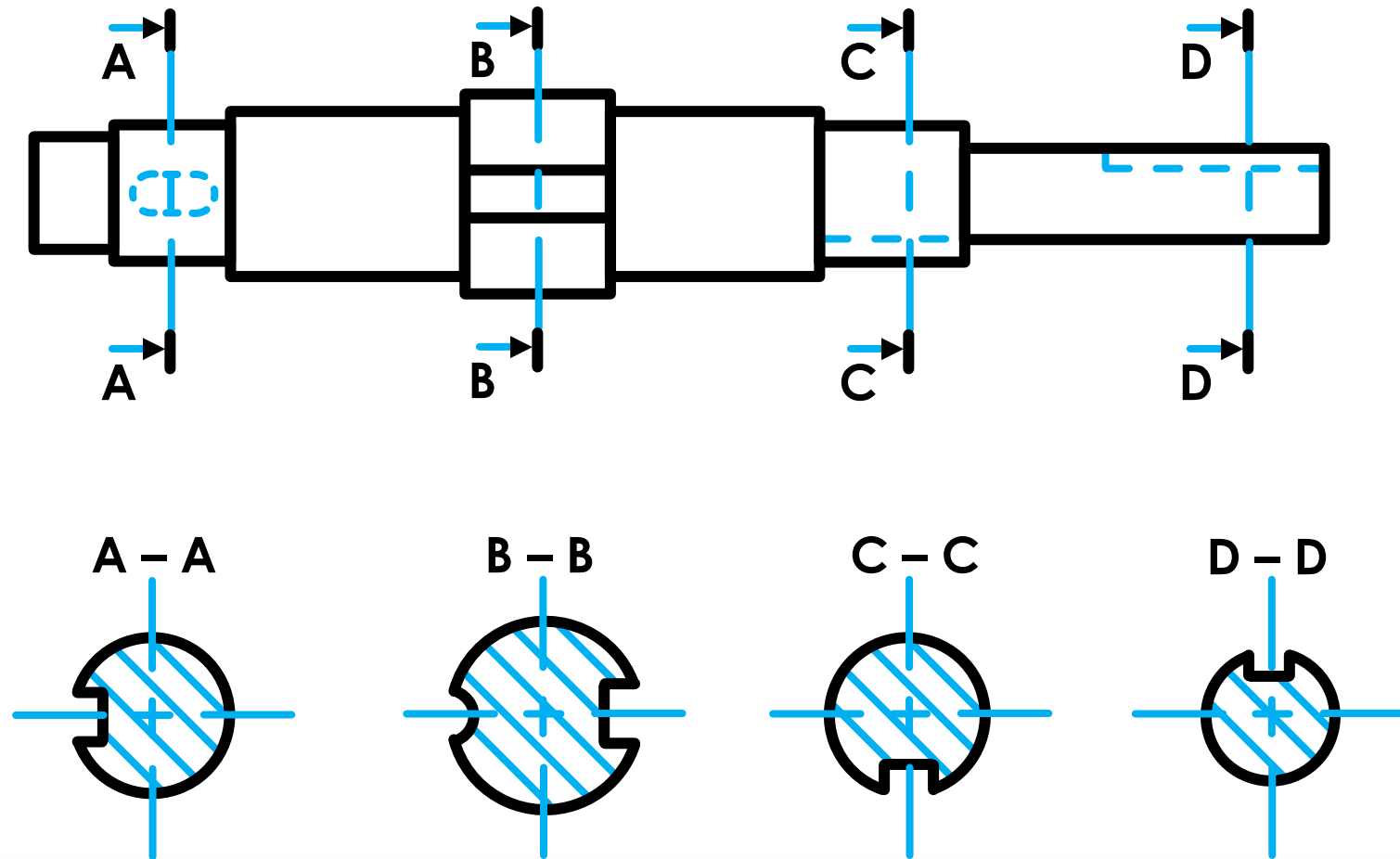

# Mechanical Drawings (sectioning)

## Aligned sections

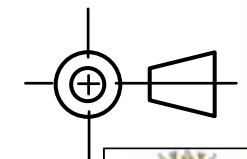
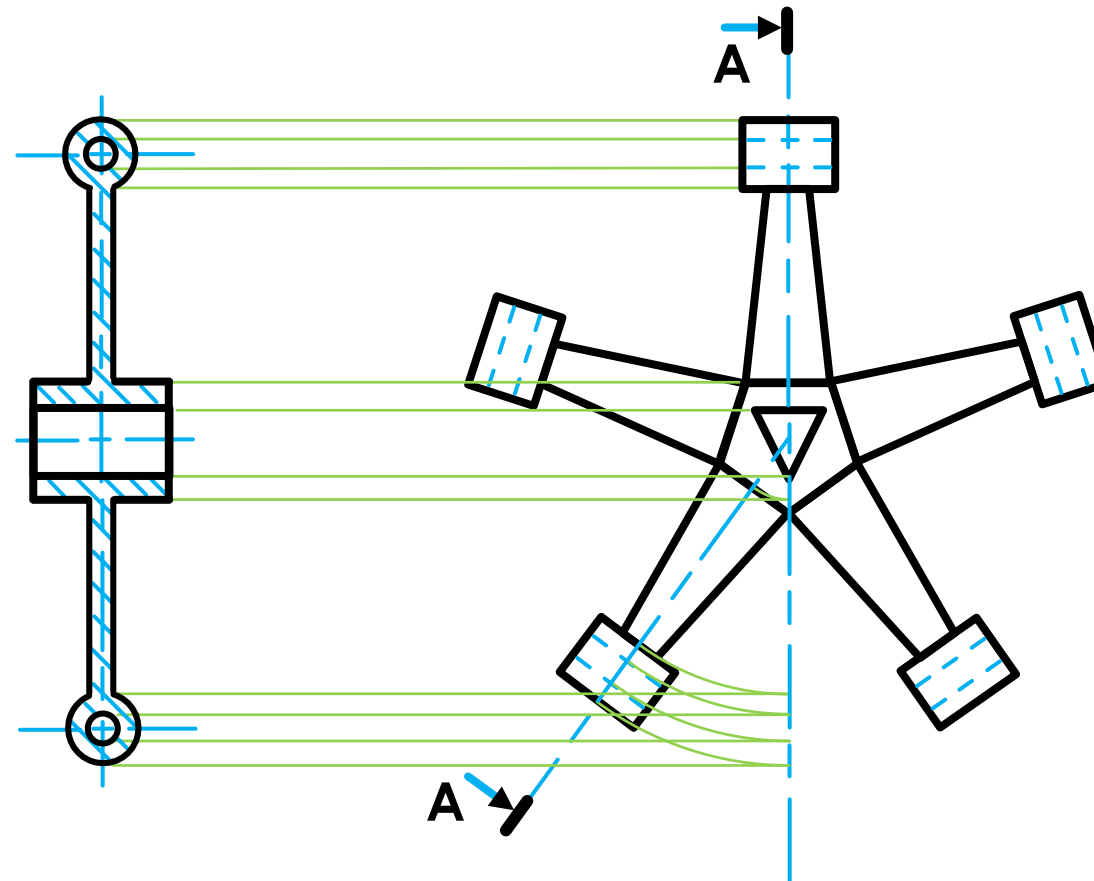

# PRESENTATION OF COMMON FEATURES

- The conventional representation of a gear.
  - Equal amount of tooth.

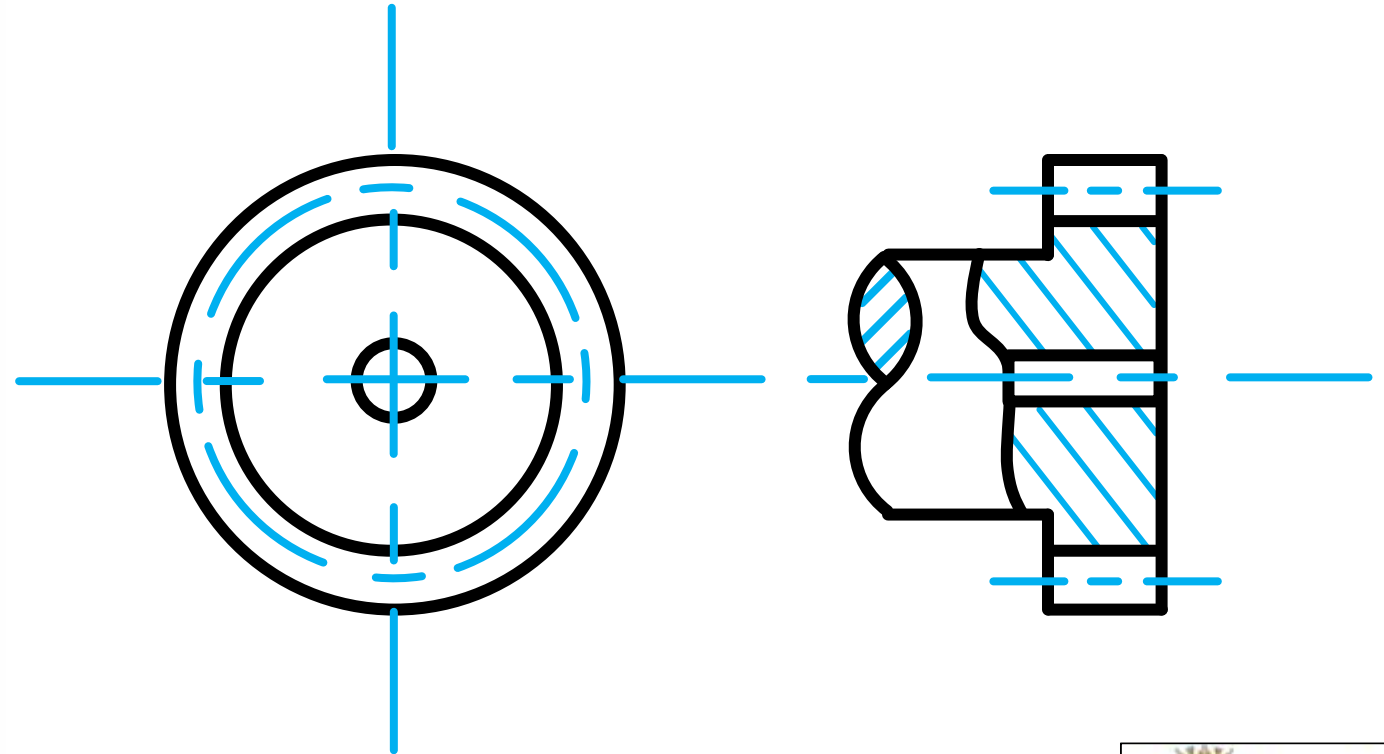

# PRESENTATION OF COMMON FEATURES

- The conventional representation of a gear.
  - Unequal amount of tooth.

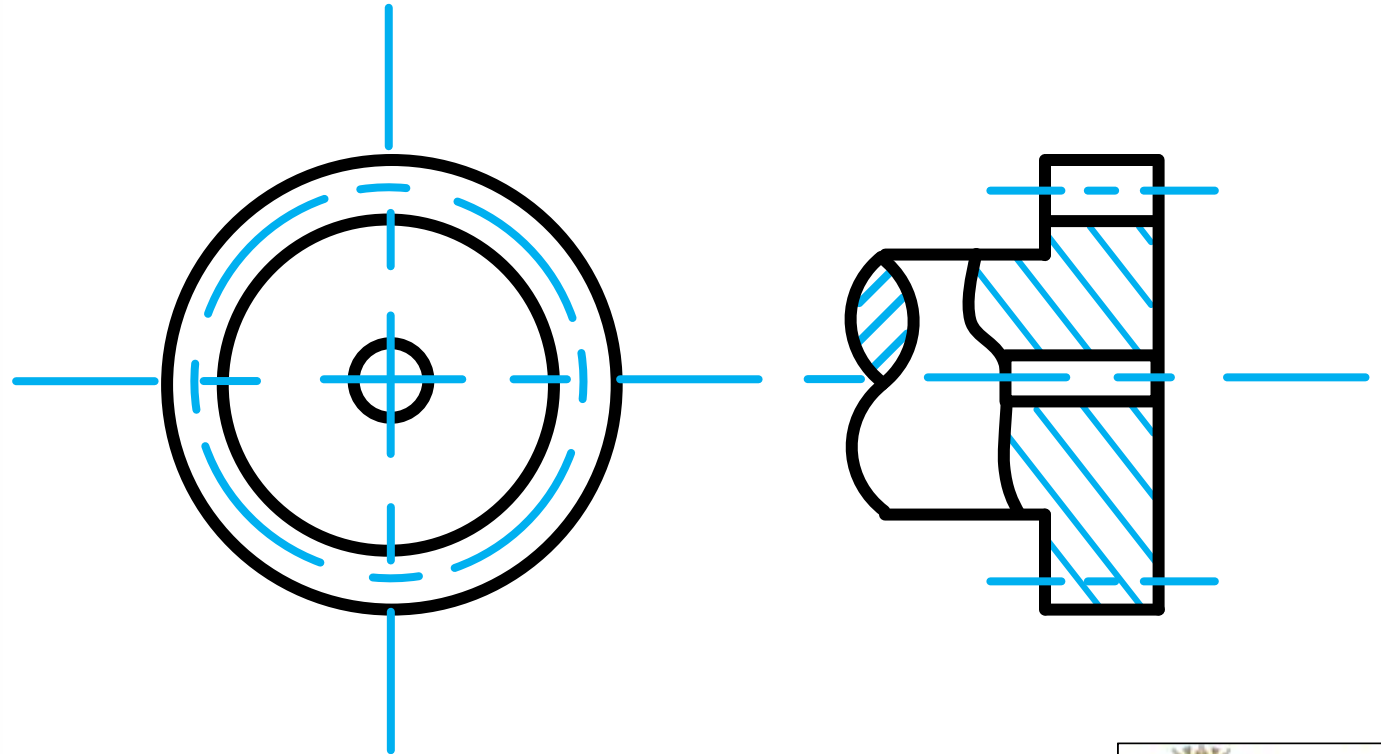

# Mechanical Drawings (sectioning)

- A **shaft** may **not** be sectioned when the cutting plane passes longitudinally through it.

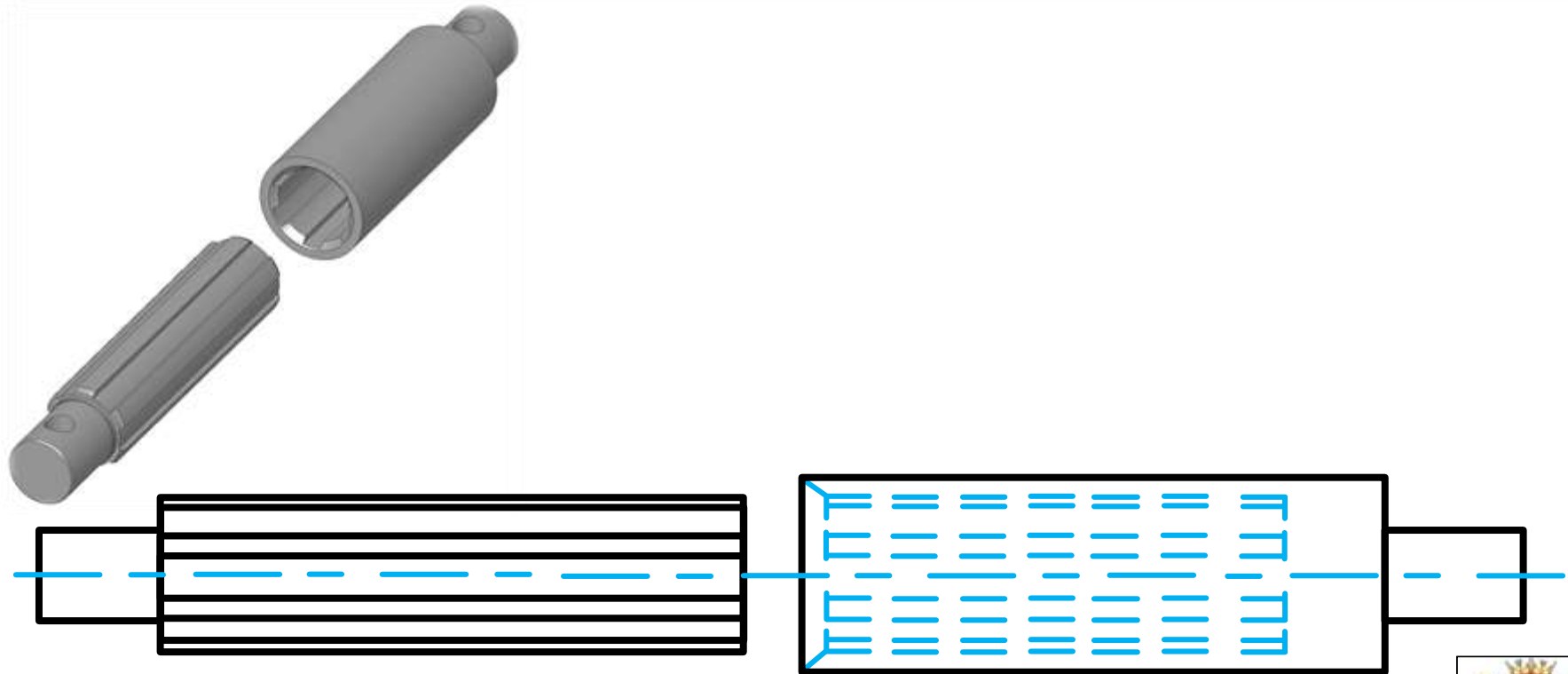

# Mechanical Drawings (sectioning)

- **Rivets** may **not** be sectioned when the cutting plane passes longitudinally through them.

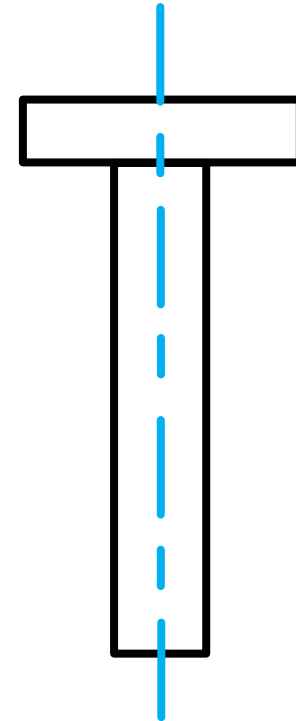

# Mechanical Drawings (sectioning)

- **Rods of any kind** may **not** be sectioned when the cutting plane passes longitudinally through them.



# Mechanical Drawings (sectioning)

- **Dowels** may **not** be sectioned when the cutting plane passes longitudinally through them.

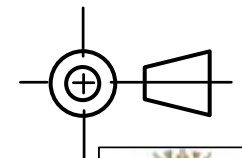
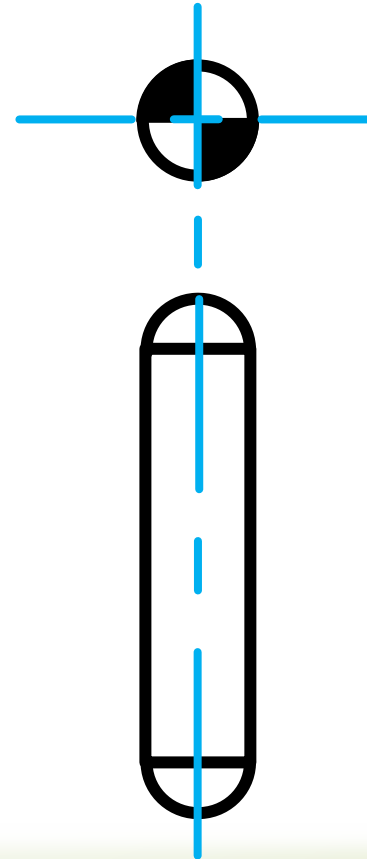

# Mechanical Drawings (sectioning)

- Pins may **not** be sectioned when the cutting plane passes longitudinally through them.

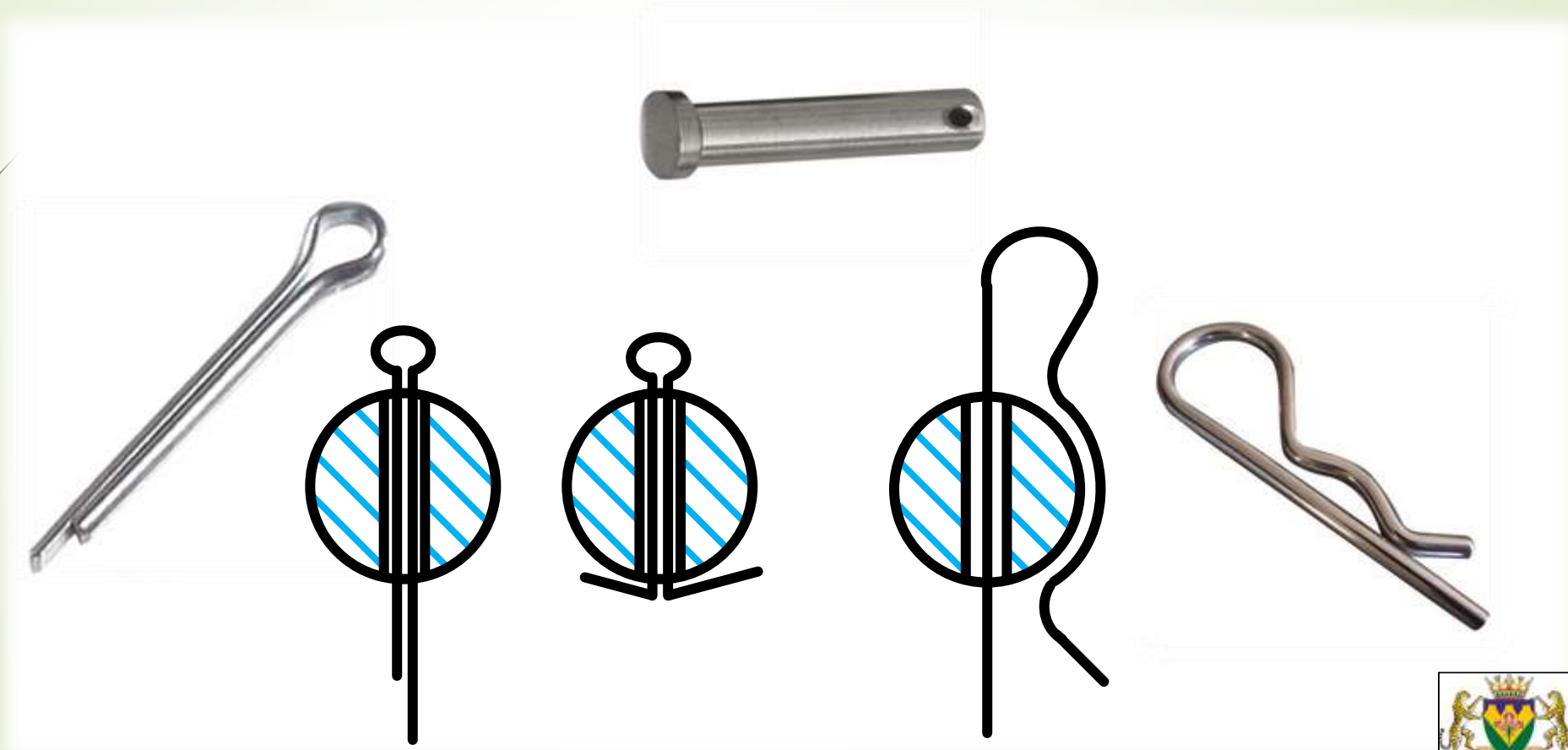

# Mechanical Drawings (sectioning)

- ▶ **Washers** may **not** be sectioned when the cutting plane passes longitudinally through them.

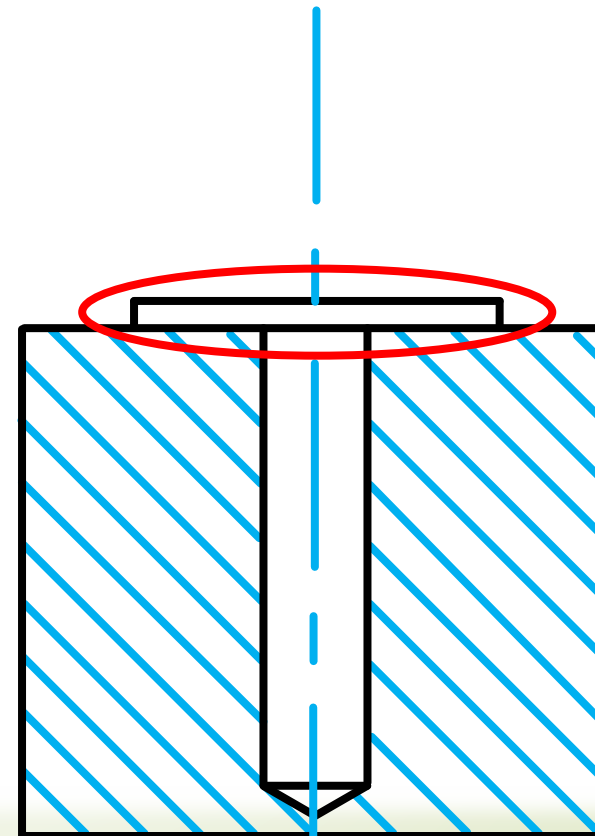

# Mechanical Drawings (sectioning)

- **Studs** may **not** be sectioned when the cutting plane passes longitudinally through them.

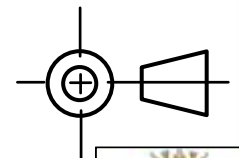
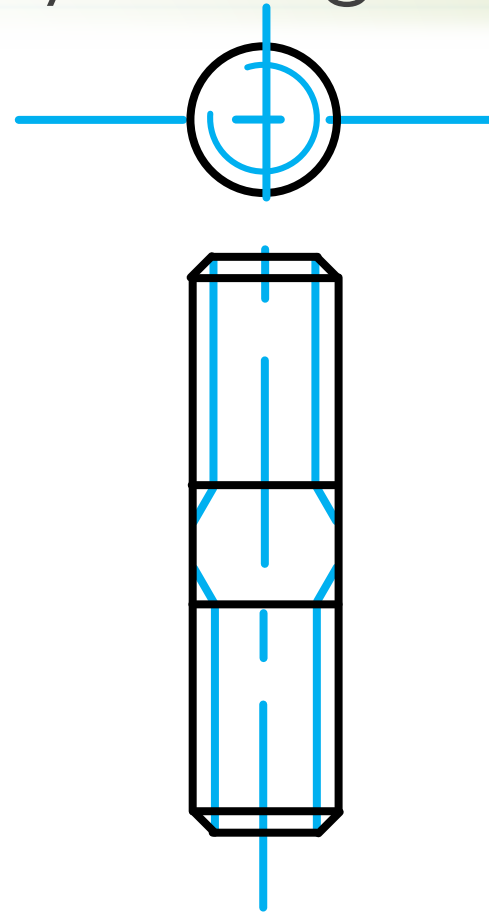

# Mechanical Drawings (sectioning)

- **Bolts** may **not** be sectioned when the cutting plane passes longitudinally through them.

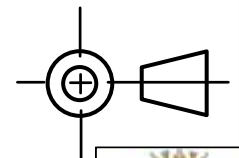
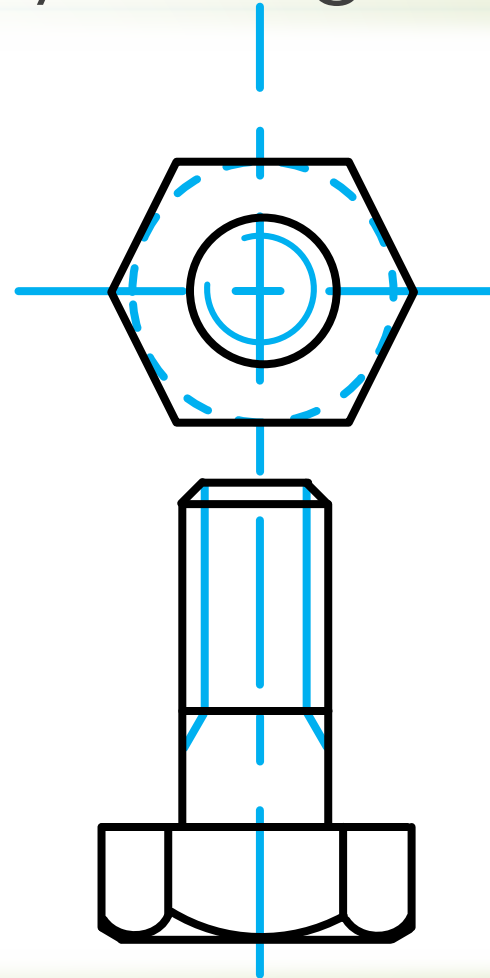

# Mechanical Drawings (sectioning)

- **Nuts** may **not** be sectioned when the cutting plane passes longitudinally through them.

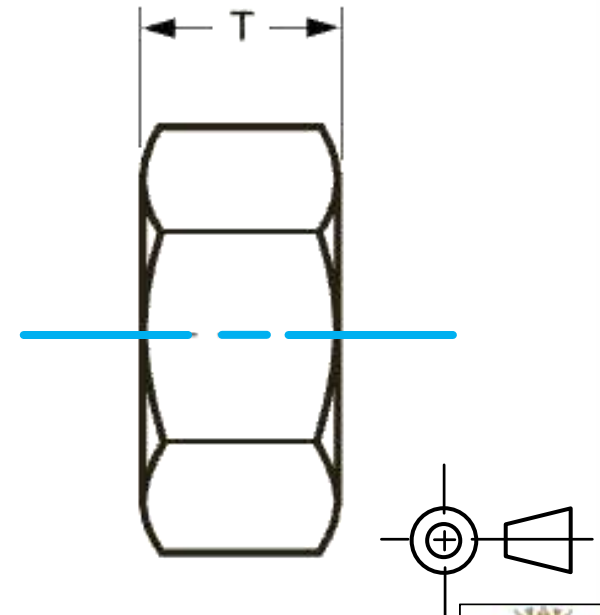
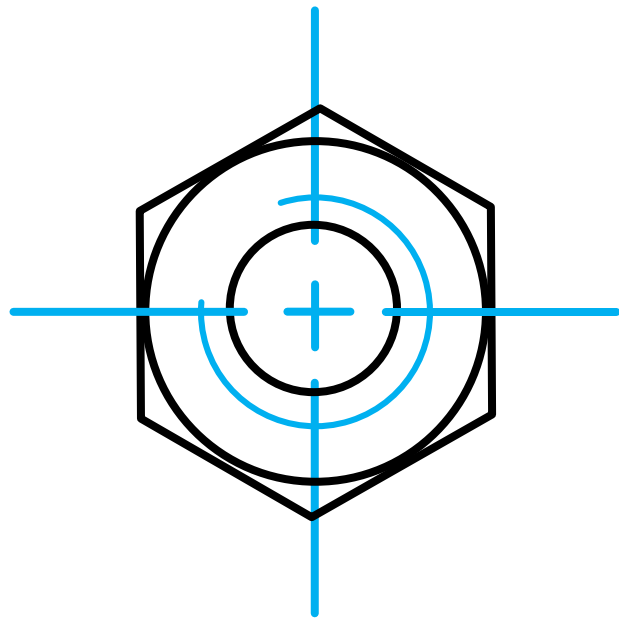

# Mechanical Drawings (sectioning)

- Keys may **not** be sectioned when the cutting plane passes longitudinally through them.

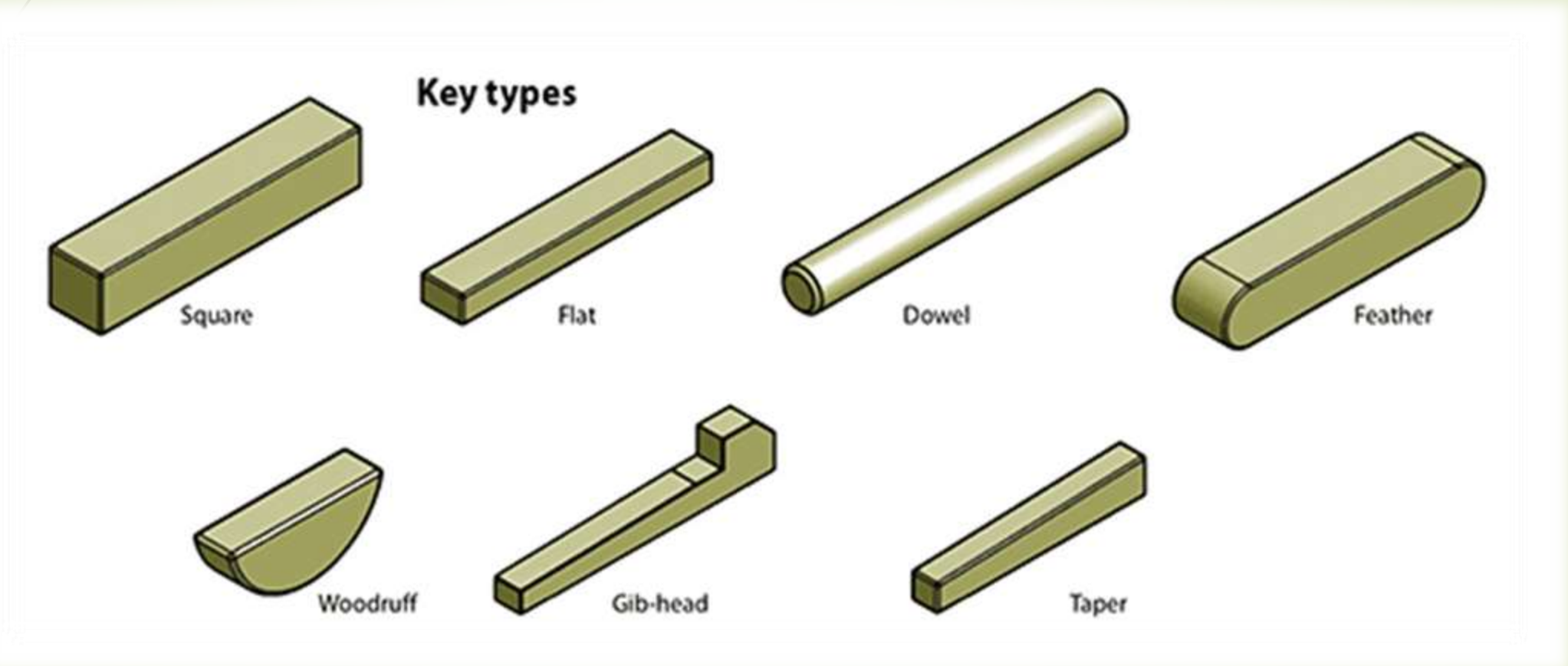

# Mechanical Drawings (sectioning)

- **Keys** may **not** be sectioned when the cutting plane passes longitudinally through them.

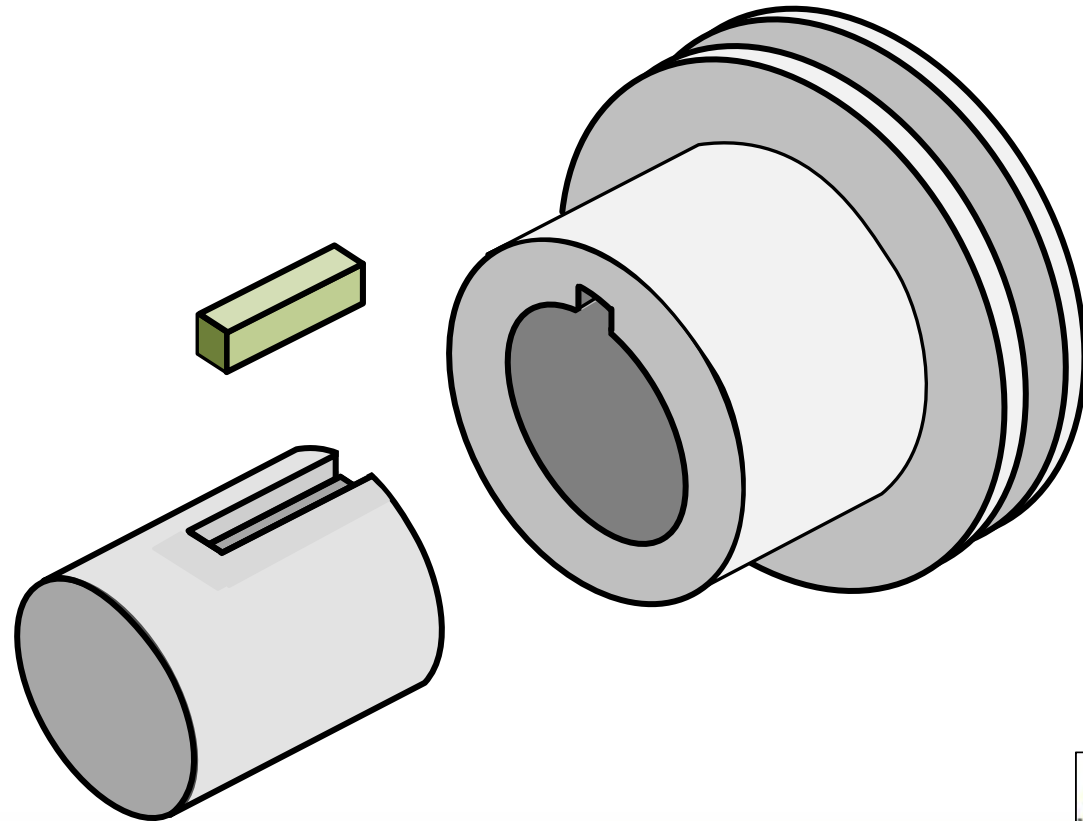

# Mechanical Drawings (sectioning)

- **Keys** may **not** be sectioned when the cutting plane passes longitudinally through them.

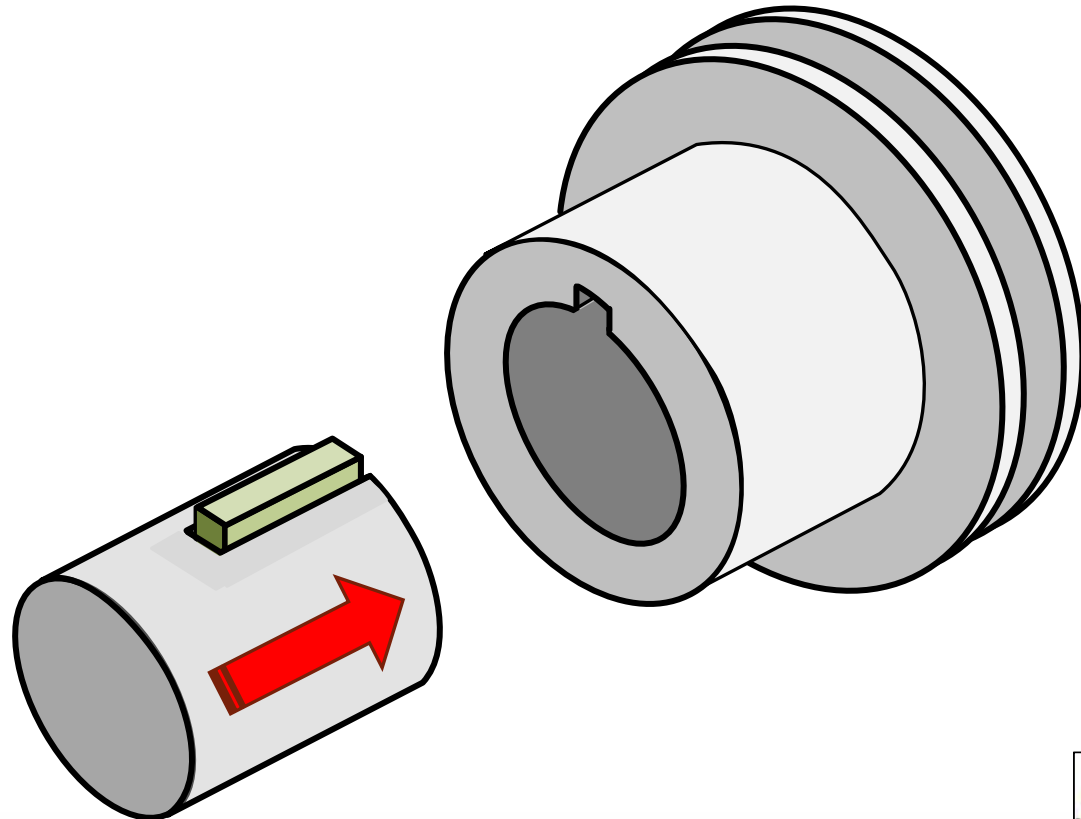

# Mechanical Drawings (sectioning)

- **Keys** may **not** be sectioned when the cutting plane passes longitudinally through them.

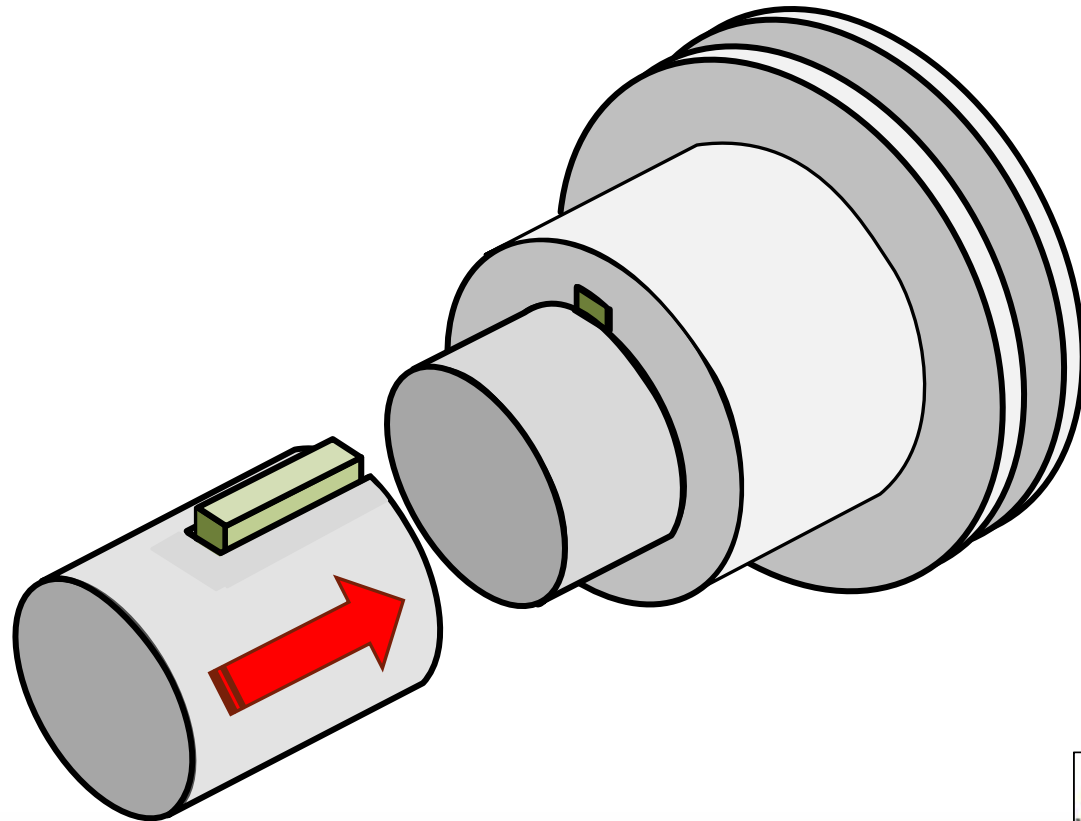

# Mechanical Drawings (sectioning)

- **Keys** may **not** be sectioned when the cutting plane passes longitudinally through them.

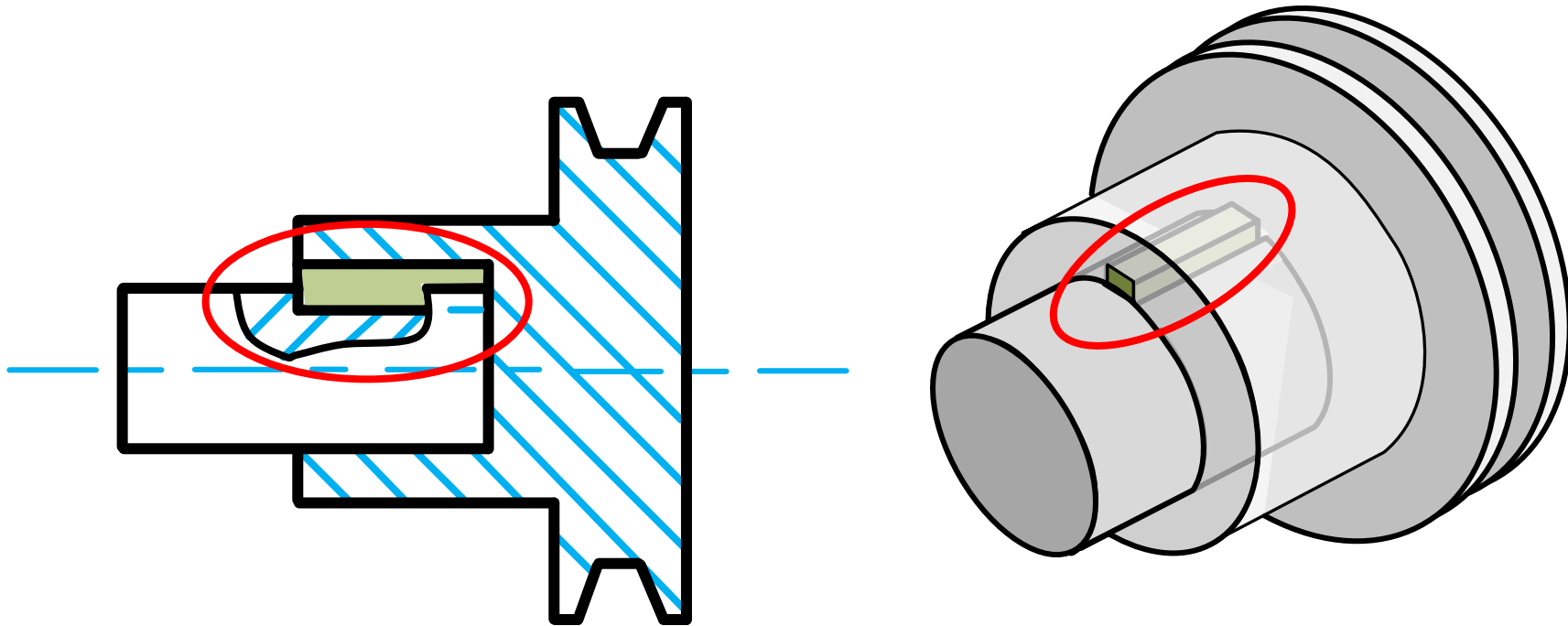

# Mechanical Drawings (sectioning)

- **Keys** may **not** be sectioned when the cutting plane passes longitudinally through them.

