



education

Department of
Education
FREE STATE PROVINCE

PROVINCIAL PAPER

GRADE 10

ENGINEERING GRAPHICS AND DESIGN

JUNE 2019

MARKS: 100
TIME: 3 HOURS

This paper consists of 6 pages.

INSTRUCTIONS AND INFORMATION

1. This question paper consist of FOUR questions.
2. Answer ALL the questions.
3. ALL drawings are in third-angle orthographic projection, unless stated otherwise.
4. ALL drawings must be drawn to scale 1:1, unless stated otherwise.
5. ALL questions must be answered on the DIAGRAM SHEETS, as instructed.
6. ALL the pages must be restapled in numerical sequence, irrespective of whether the question was attempted or not.
7. Time management is essential in order to complete all the questions.
8. Print your name and surname as well as the grade in the space provided on each page.
9. ALL answers must be drawn accurately and neatly.
10. ALL necessary construction and projection lines must be shown.
11. Plan each drawing carefully from the given position, which is indicated on the diagram sheets.
12. Any details or dimensions not given must be assumed in good proportion.

FOR OFFICIAL USE ONLY								
QUESTION	MARKS OBTAINED			½	MODERATED			½
1								
2								
3								
4								
TOTAAL/ TOTAL	1	0	0		1	0	0	

FINAL CONVERTED MARK	CHECKED BY
100	

NAME & SURNAME	MEMORANDUM	GRADE	10	1
----------------	-------------------	-------	-----------	----------

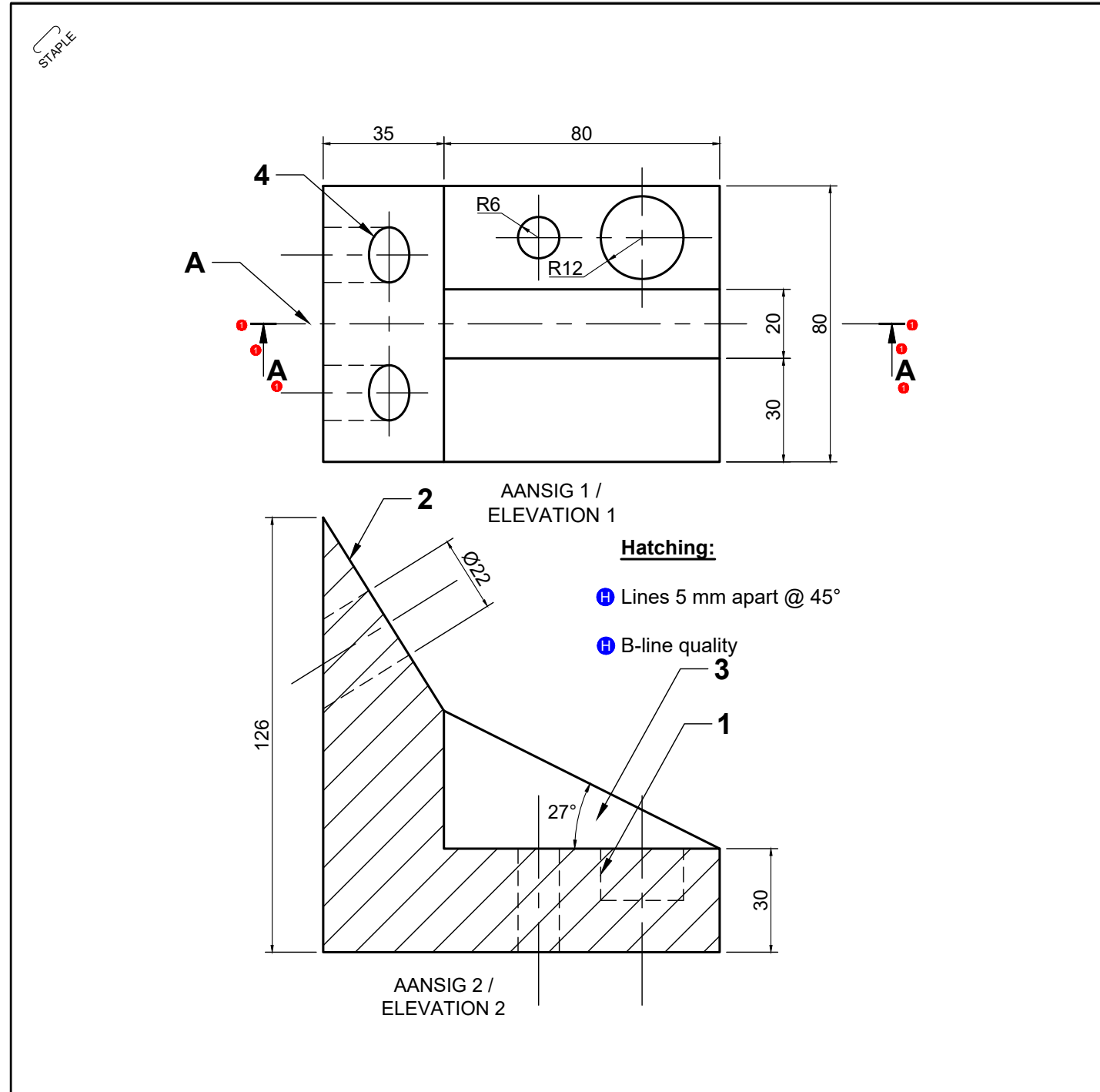

QUESTION 1: ANALYTICAL (MECHANICAL)

Given:

Diagram sheet 1 shows the working drawings of a cutting block in third angle orthographic projection with a title block and a table with questions.

Instructions:

With a pencil, complete the table by neatly printing the correct answers in the corresponding answer column.

Note: All the questions refer to the accompanying drawing and the title block on this diagram sheet.

[22]

QUESTIONS		ANSWERS		
1	What is die name of the manufacturing firm?	H&M STEELWORKS	1	
2	What is the scale of the drawing?	SCALE 1:2	1	
3	What is the title of the drawing?	CUTTING BLOCK	1	
4	How many units must be manufactured?	100 UNITS	1	
5	On what date was the drawing approved?	02/03/2018	1	
6	What was the reason for revision?	DIMENSIONS REQUIRED	1	
7	Which measuring unit is used in the drawing?	MILLIMETERS/mm	1	
8	Which material is used to manufacture the unit?	SOFT STEEL	1	
9	Who changed the drawing?	DD DUBE	1	
10	What tipe of treatment must be done on the unit?	PAINT	1	
11	Name view 2.	FRONT VIEW	1	
12	Name the line type at 1.	HIDDEN OUTLINE/DASH LINE	1	
13	Name the line quality of the line numbered 2.	A - QUALITY	1	
14	Name the phenomenon at 3.	WEB	1	
15	Name the diameter for the hole at 4.	Ø 22	1	
16	Determine the size of the angle at 3.	27°	1	
17	Who checked the drawing?	DAVID	1	
18	Draw the hatch lines of the sectioned area on view 2 as determined by cut line A.		2	
19	Draw in the section line A-A if view 2 is sectioned at the line which is numbered A. (6/2)		3	
TOTAL			22	

TITLE: CUTTING BLOCK

H&M STEELWORKS

11 JOCK STREET, www.hmsw@yahoo.com, BOKSBURG, Phone No:011 811 2223

DATE: 2018/02/15	MATERIAL: SOFT STEEL	NUMBER REQUIRED: 100	SCALE: 1:2	DRAWING PROGRAM: AUTOCAD 2017	CHANGED BY: DD DUBE	NOTES: ALL THE DIMENSIONS ARE IN MILLIMETERS. ALL THE DIMENSIONS THAT IS NOT GIVEN MUST BE DETERMINED IN GOOD RATIO.
DESCRIPTION OF REVISION: DIMENSIONS REQUIRED	DRAWN BY: JULIUS	CHECKED BY: DAVID	APPROVED BY: TSEPOSISO	DRAWING FILE No.: CAD 3 of 2018	DRAWING NUMBER: 3	
	DATE DRAWN: 12/02/2018	DATE CHECKED: 26/02/2018	DATE APPROVED: 02/03/2018	TREATMENT: PAINT		

DIAGRAM SHEET 1	ENGINEERING GRAPHICS AND DESIGN	FS DoE - JUNE 2019	NAME & SURNAME	MEMORANDUM	GRADE	10	2
-----------------	---------------------------------	--------------------	----------------	-------------------	-------	-----------	----------

QUESTION 2: GEOMETRICAL CONSTRUCTION

Given:

Diagram sheet 2 (page 3) shows a representation of a tool with the necessary dimensions. The starting position A, circle B, point E, C, G and H and with some lines already added to the drawing.

Instructions:

Use the given sketch on diagram sheet 2 and according to scale 1:1, construct by means of your drawing instruments the following:

- 1.1. At point C, construct a circle with a diameter of 36 mm as a continuous (visible outline) line quality.
- 1.2. By means of your T-square, draw from point A, a construction (continuous thin) line to the left, 102 mm in length. Name the line segment AD.
- 1.3. By means of construction, divide line segment AD in three equal parts. Show all necessary construction lines and number each dividing part from 1 to 3.
- 1.4. Construct from last mentioned points A, 1, 2 and 3 according to 30° and 60° the given zig-zag lines as indicated on the sketch.
- 1.5. Use the given dimensions for lines DF and EF and determine position F. Join points DF and EF as a continuous (visible outline) line quality.
- 1.6. From point G, determine the rectangle according to the degrees and dimensions as indicated on the sketch.
- 1.7. From point E, construct a tangent continuous (visible outline) line quality towards circle C.
- 1.8. Construct an internal arc with a continuous (visible outline) line quality with a radius of 75 mm towards the two circles B and C so that both the two circles are excluded from the internal arc.
- 1.9. Use H as the center point and construct an ellipse by means of a continuous (visible outline) line quality. The vertical axis should be 36 mm and the horizontal axis should be 60 mm.

Note:

- Show ALL construction lines.
- Show ALL calculations.

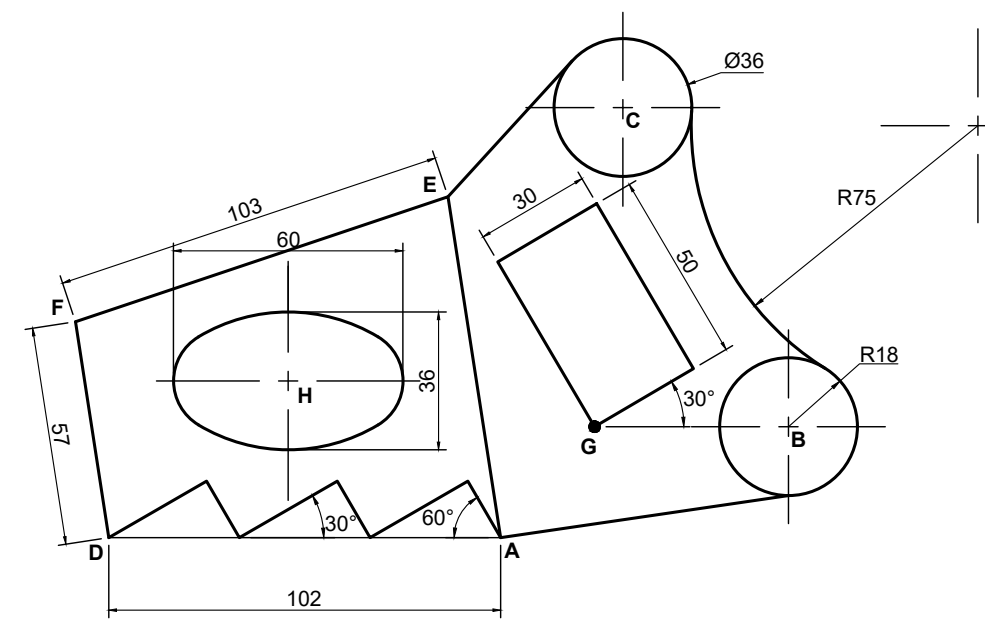

- 5 Continuous dark A-quality
- 5 DF length correct
- 5 EF length correct
- 5 F indicated

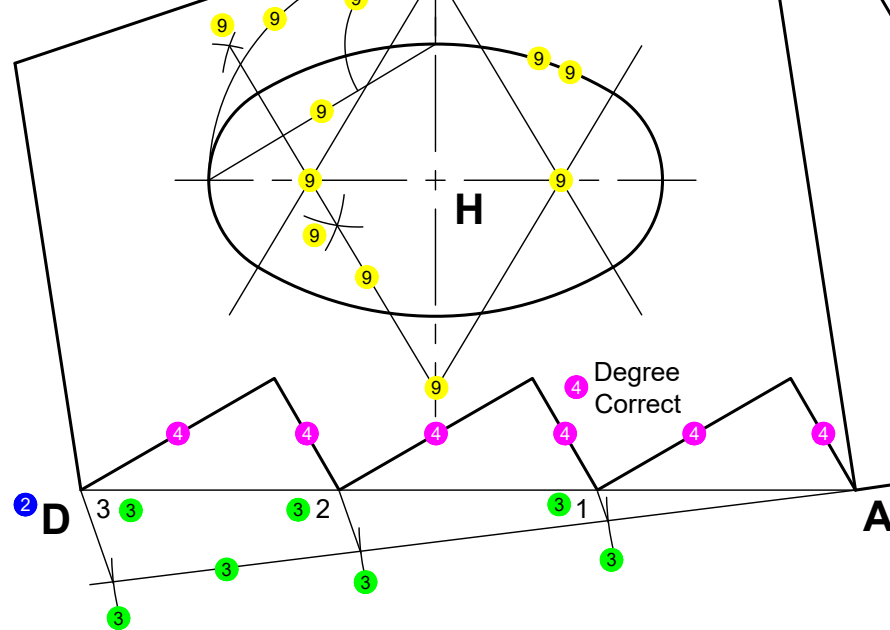

2 Continuous thin line (C-quality)

6 Degree correct
6 Position correct

[28]

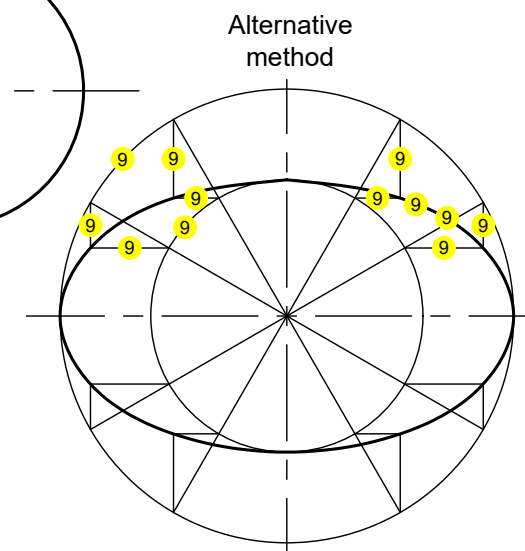
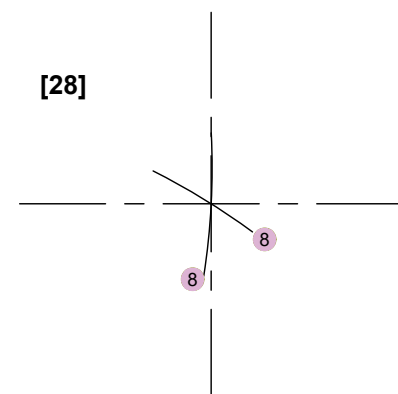

ASSESSMENT CRITERIA				
1.1	Circle C	✓1	2	
1.2	Line segment AD (2)	2	1	
1.3	Dividing of line AD (2)	3	3.5	
1.4	Zig Zag lines (2)	4	3.5	
1.5	Line segment DF and EF (2)	5	2	
1.6	Rectangle from point G (2)	6	3	
1.7	Tangent line (2)	7	3	
1.8	Internal arc (2)	8	4	
1.9	Ellipse (12)	9	6	
TOTAL			28	

CALCULATIONS

R (Raakboog) + r (Sirkel) 8

R 75 + r 18 8

R93 8

STAPLE

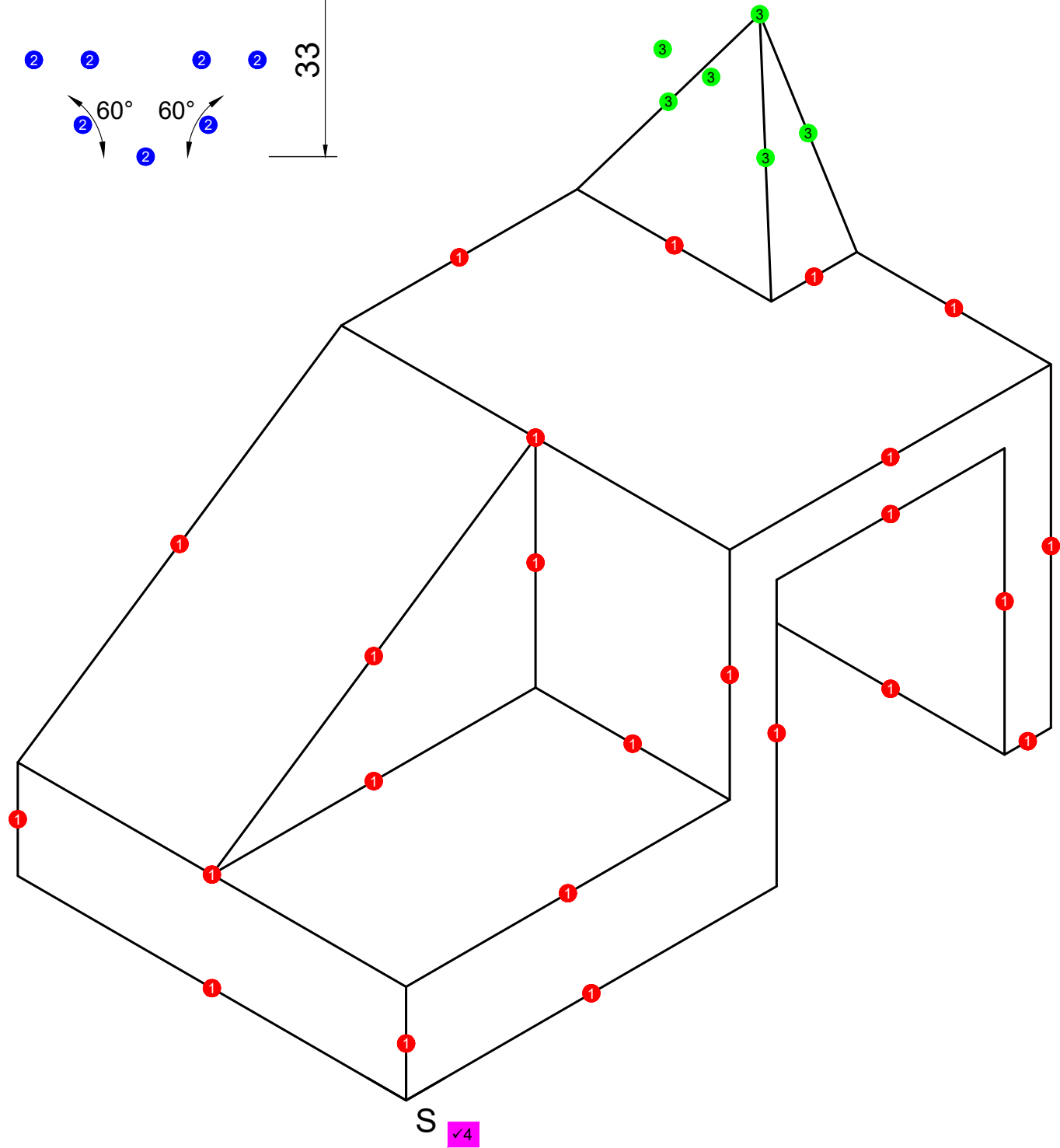
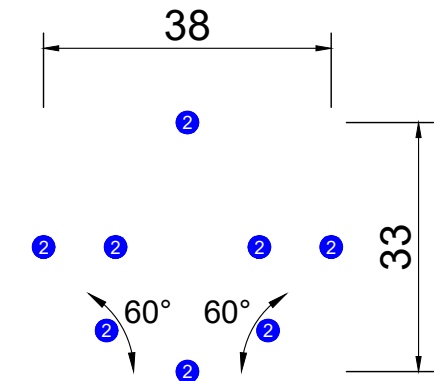

QUESTION 3: ISOMETRIC DRAWING

Given

The front view, left view and top view of a casting in third-angle-orthographic-projection. The starting point S on diagram sheet 3 (page 4).

Instructions:

With point S as the lowest point and to scale 1:1, draw an isometric drawing of the casting.

- No hidden detail is required.
- Show ALL necessary construction.

[20]

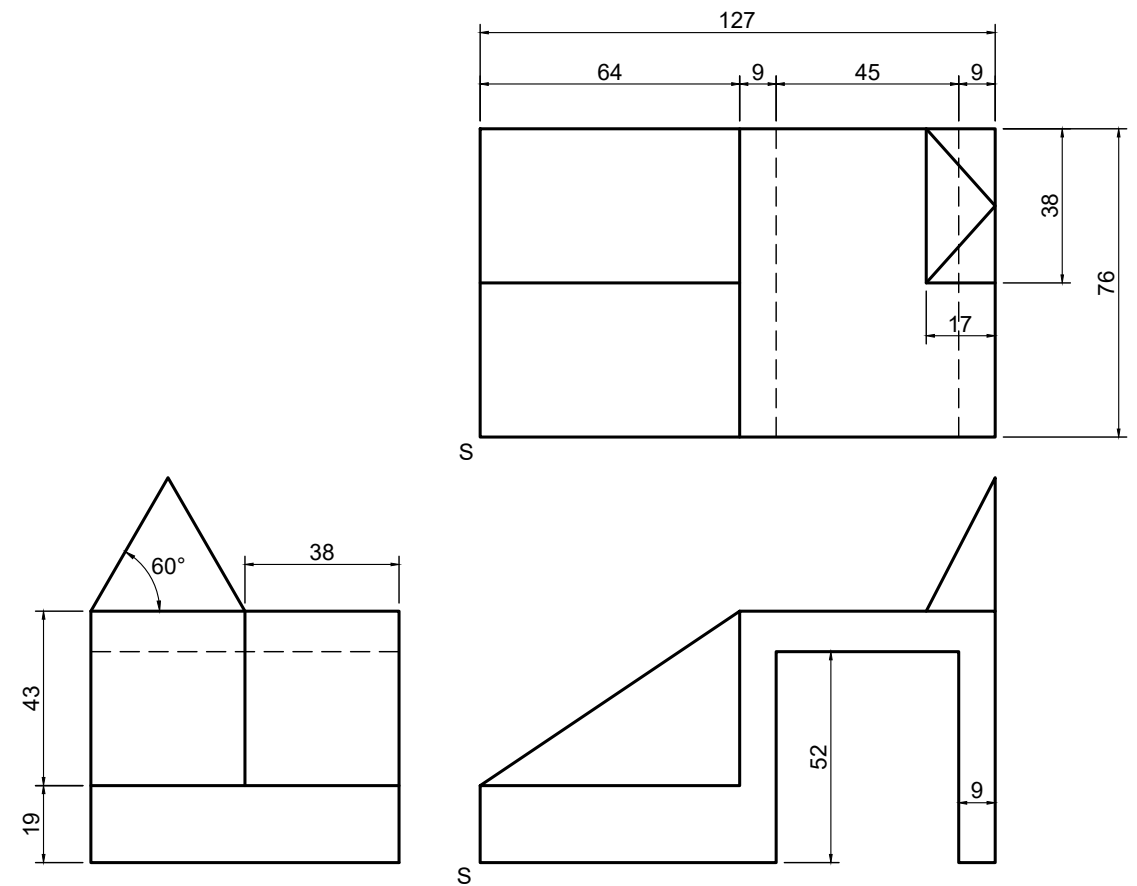

ASSESSMENT CRITERIA			Mark	Mod.
1	Isometric lines ($\frac{24}{2}$)	1	12	
2	Auxiliary view ($\frac{8}{2}$)	2	4	
3	Non-isometric lines ($\frac{6}{2}$)	3	3	
4	Placing	4	1	
TOTAL			20	

STAPLE

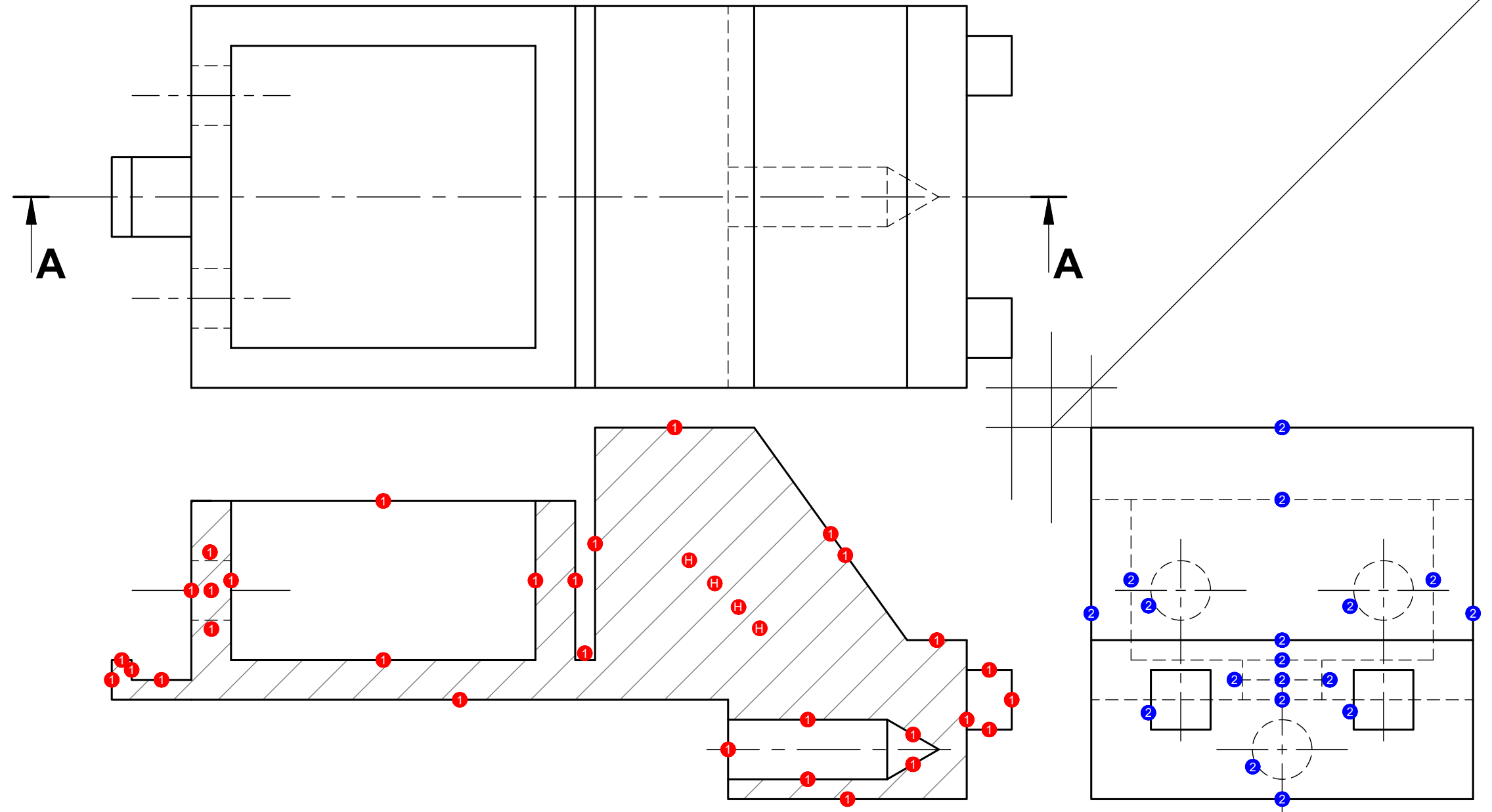

TITLE & SCALE	
CASTING	✓3
SCALE 1:1	✓3
PROJECTION SYMBOL	
	✓4

ASSESSMENT CRITERIA			Mark	Mod.
1	Sectioned front view ($\frac{34}{2}$)	1 1	17	
2	Right view ($\frac{18}{2}$)	2	9	
3	Title and scale	✓3	2	
4	Symbol of projection	✓4	2	
TOTAL			30	