

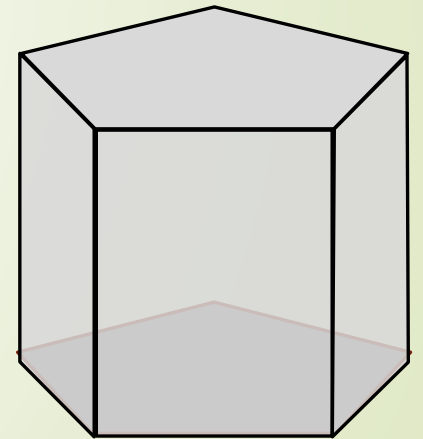

# Application on polygons

# SOLID GEOMETRY

- Projecting right regular pyramids, prisms, cones and cylinders from polygons.

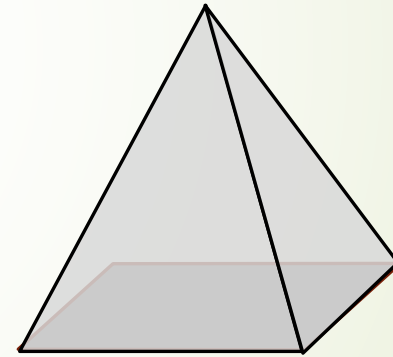
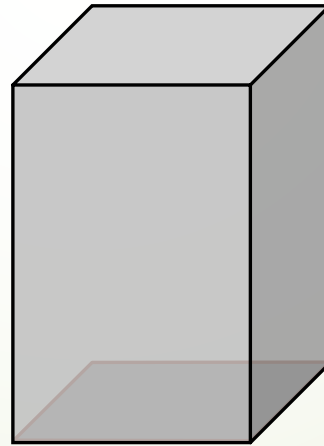
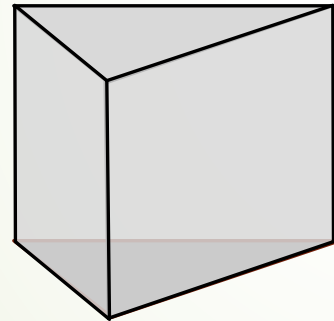
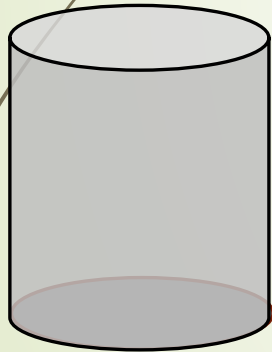

# Application on pyramids, prisms, cones and cylinders

- ➔ Draw inclined pyramids, prisms, cones and cylinders in first angle orthographic projection.

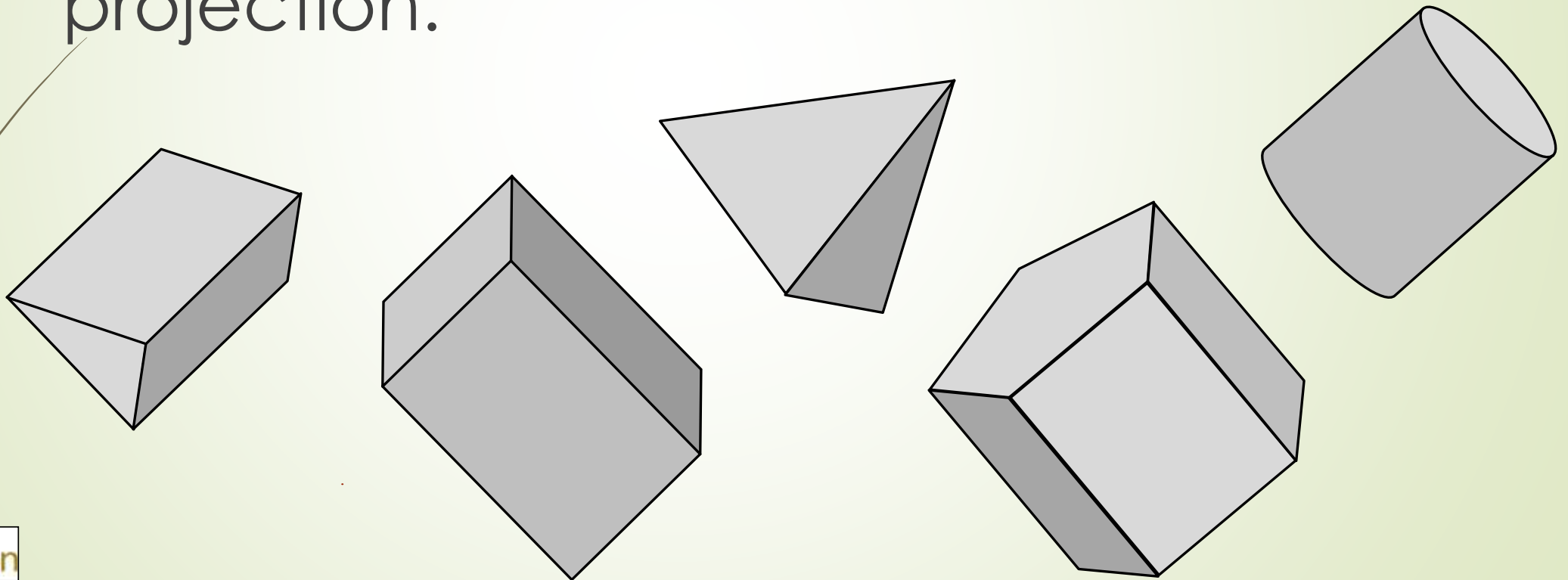

# Application on pyramids, prisms, cones and cylinders

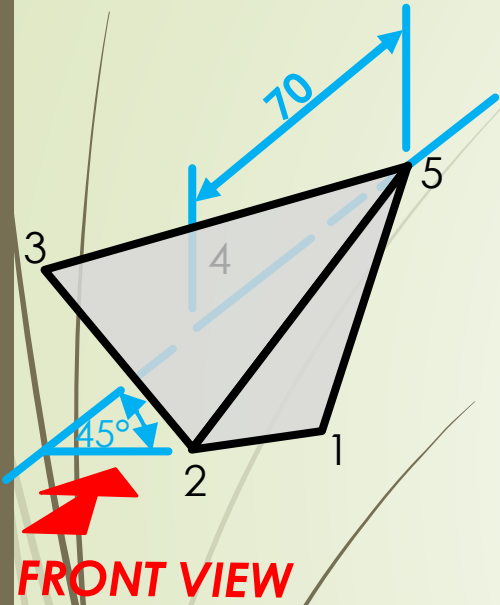

**FRONT VIEW**

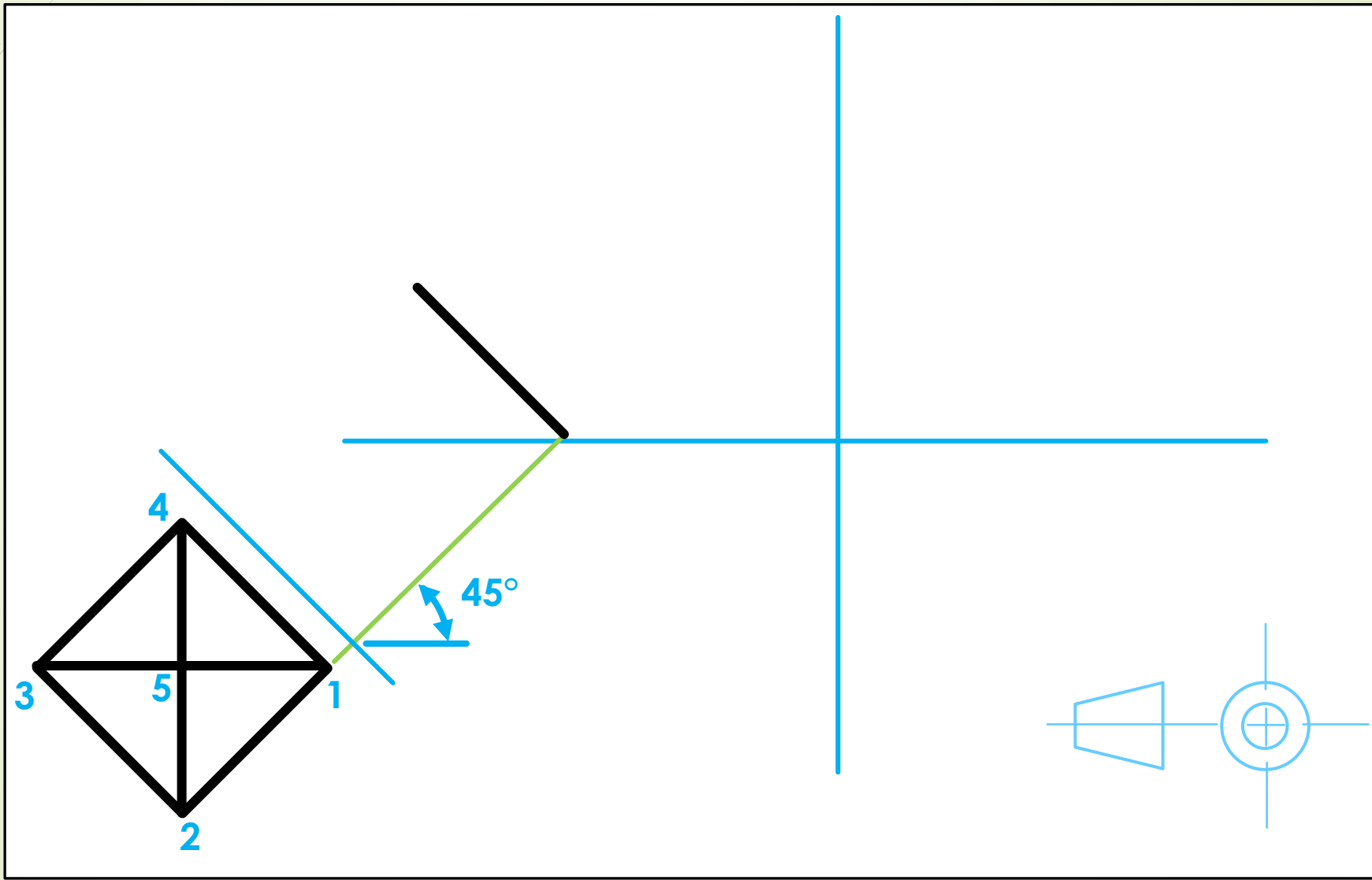

# Application on pyramids, prisms, cones and cylinders

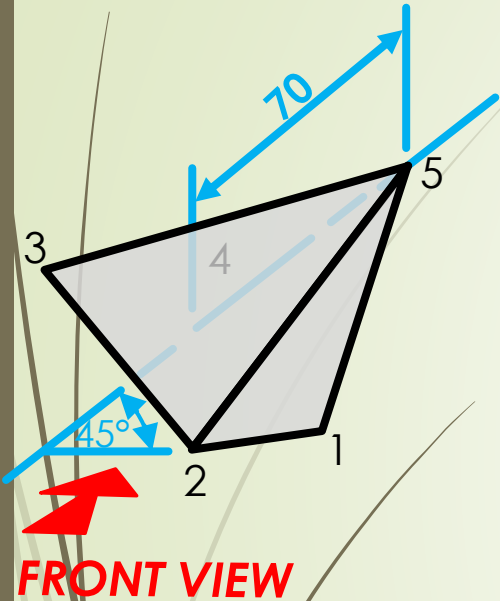

FRONT VIEW

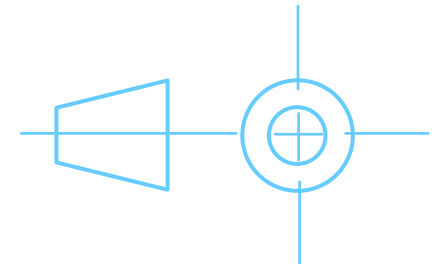
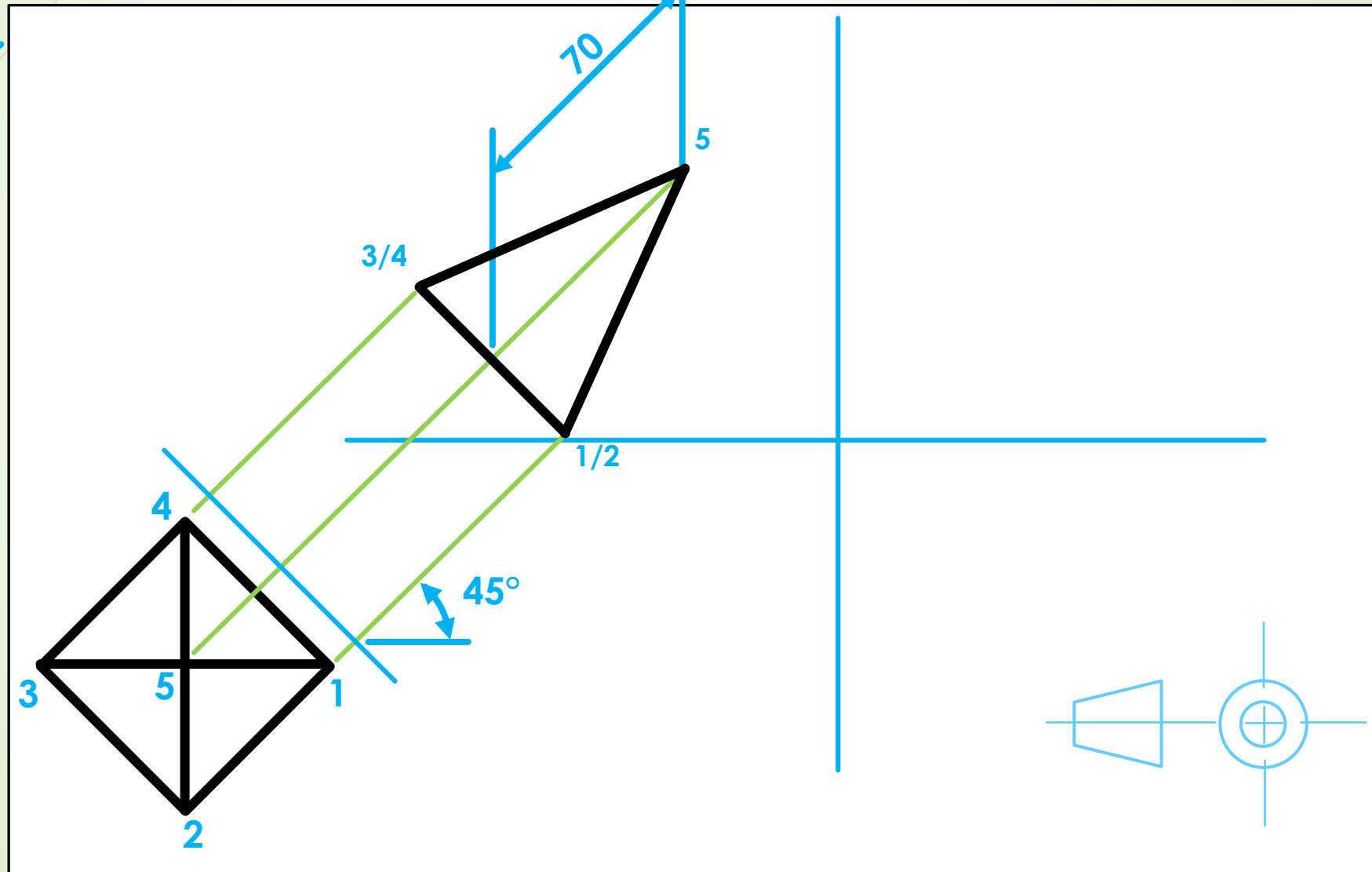

# Application on pyramids, prisms, cones and cylinders

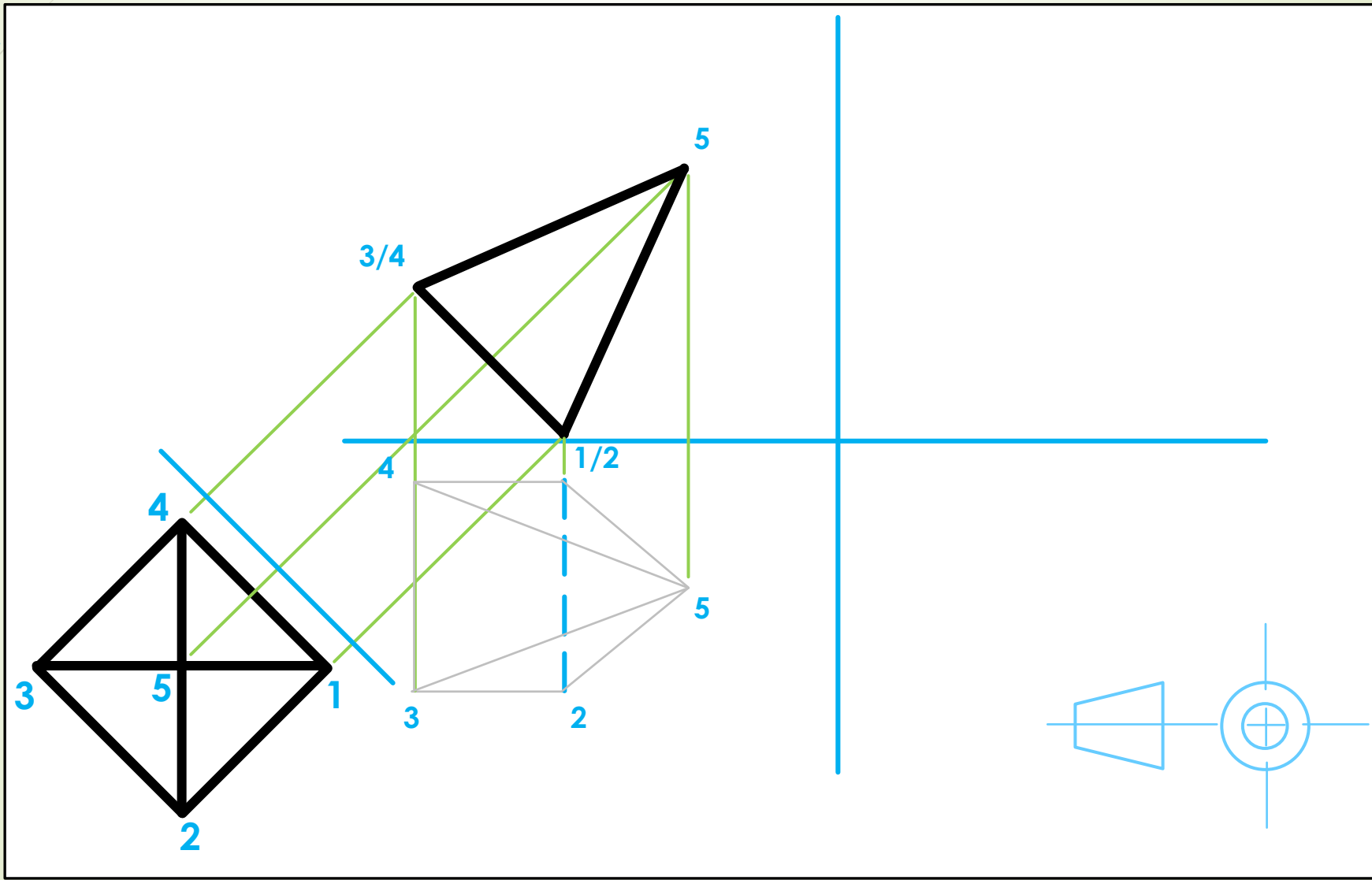
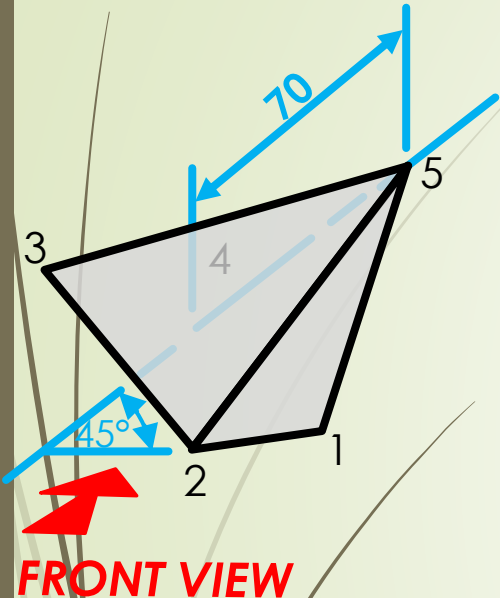

# Application on pyramids, prisms, cones and cylinders

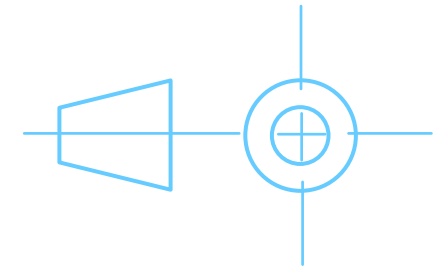
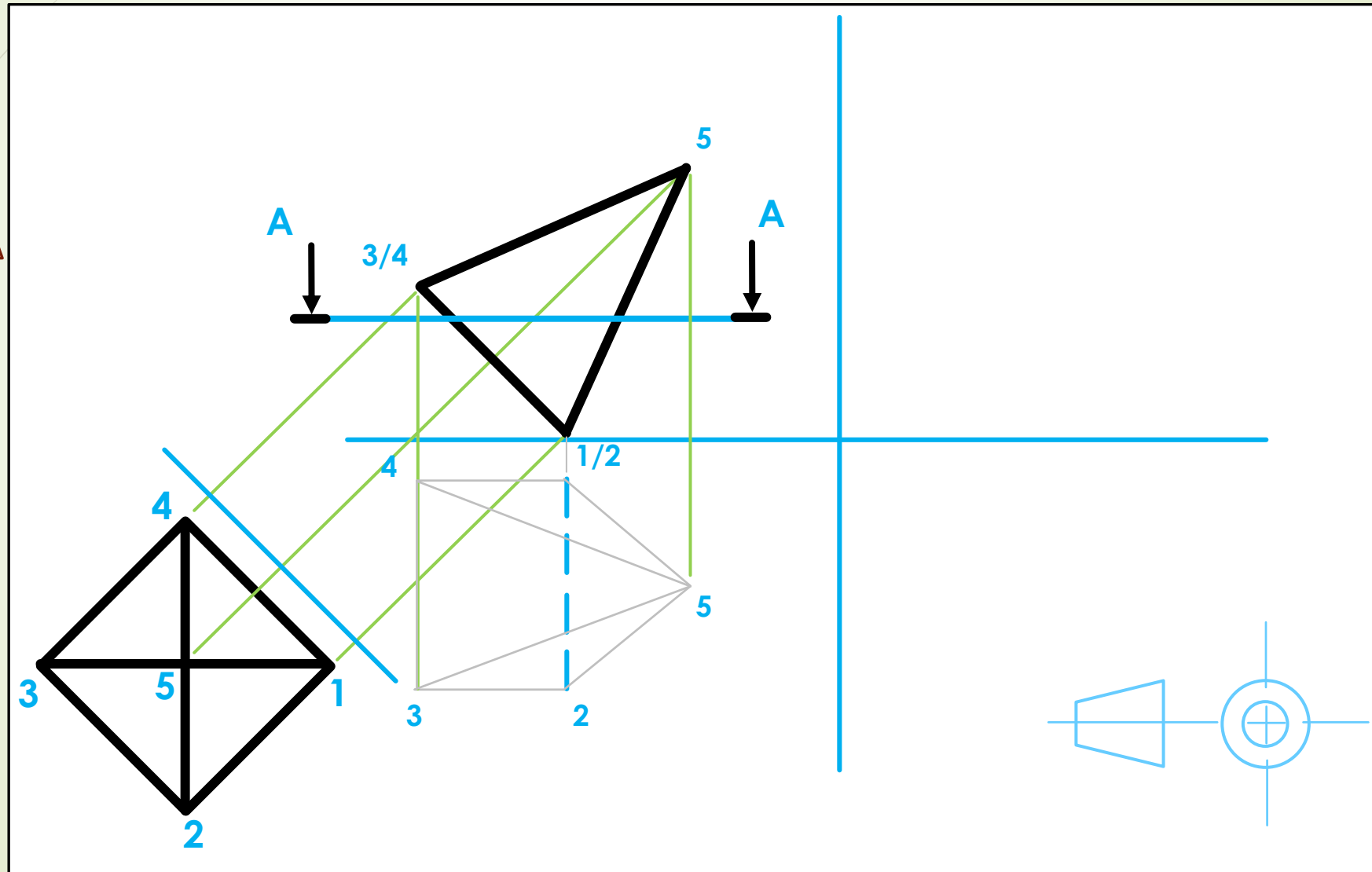
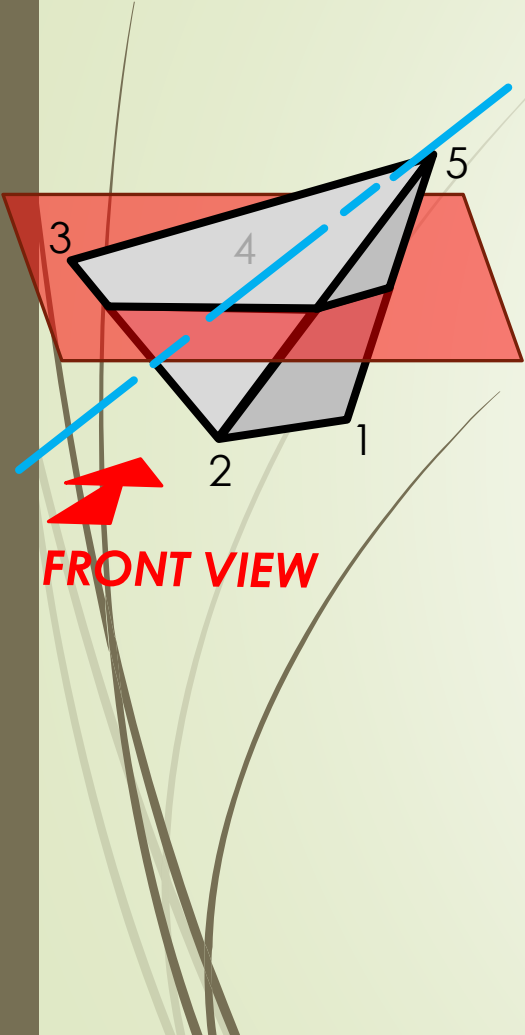

# Application on pyramids, prisms, cones and cylinders

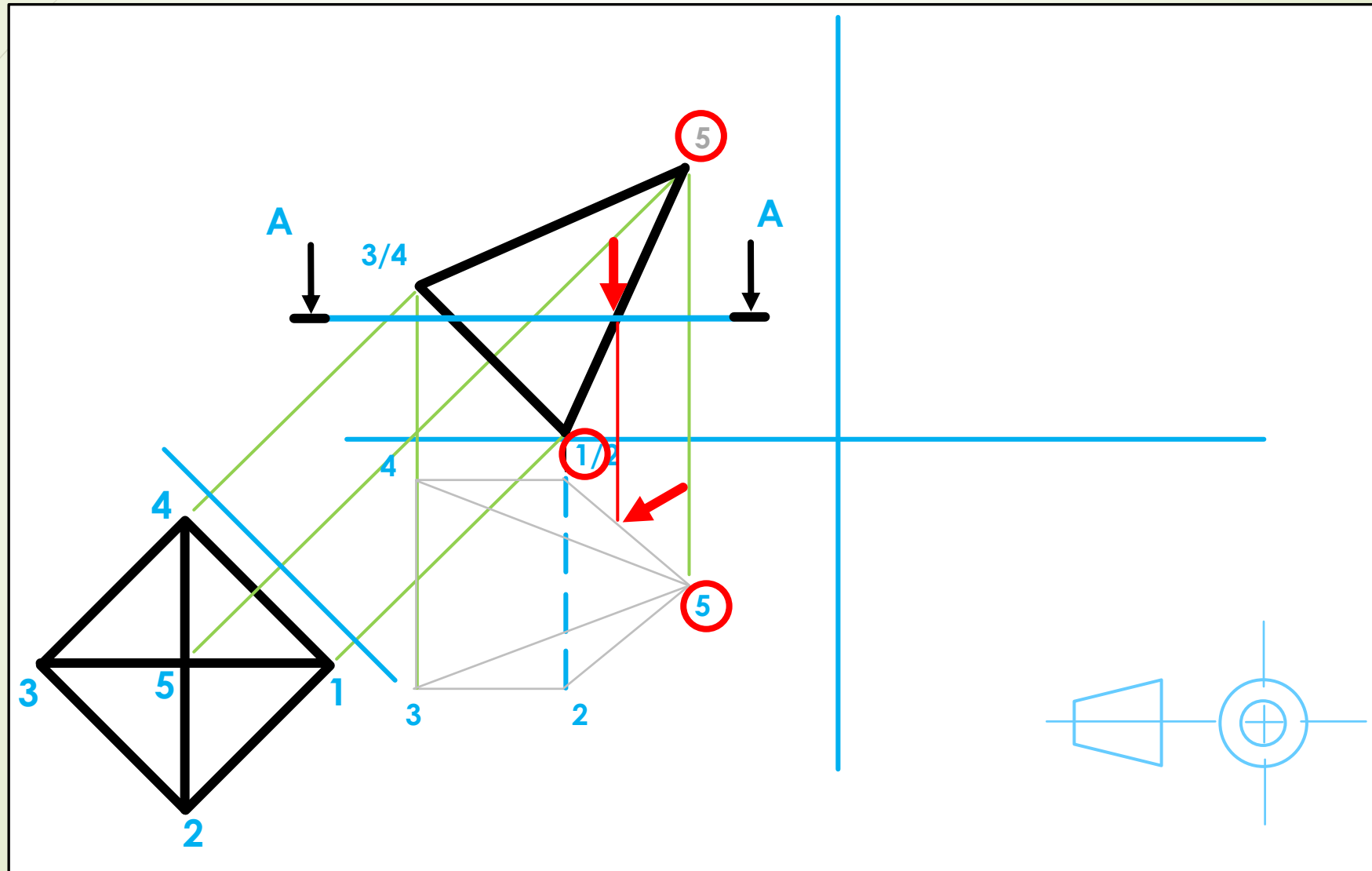
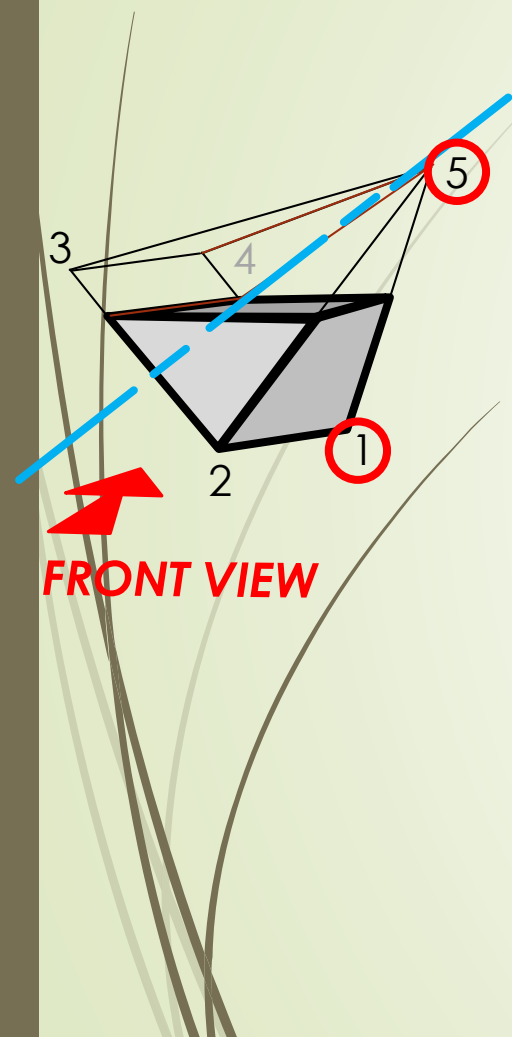

# Application on pyramids, prisms, cones and cylinders

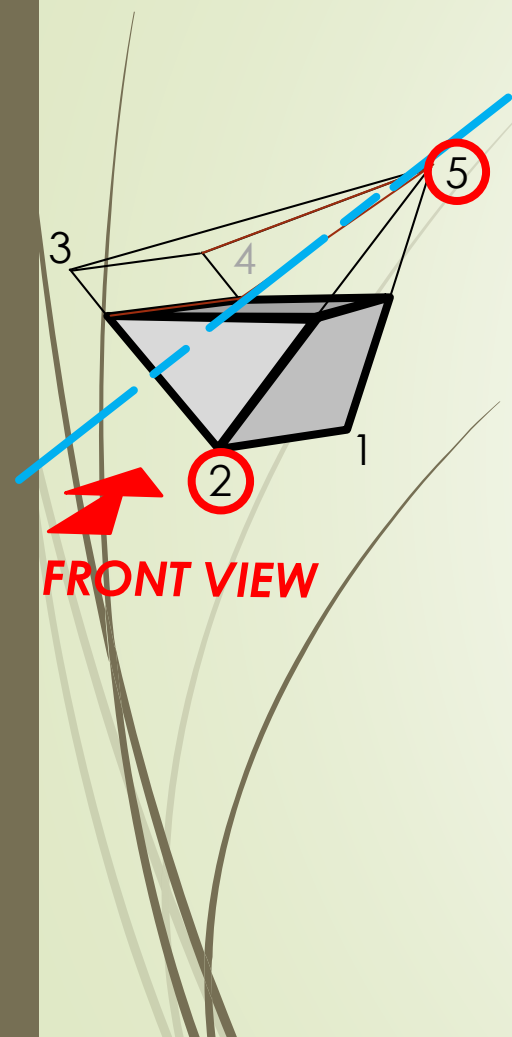

FRONT VIEW

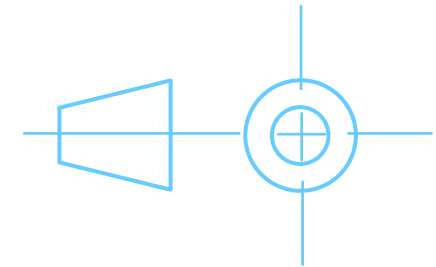
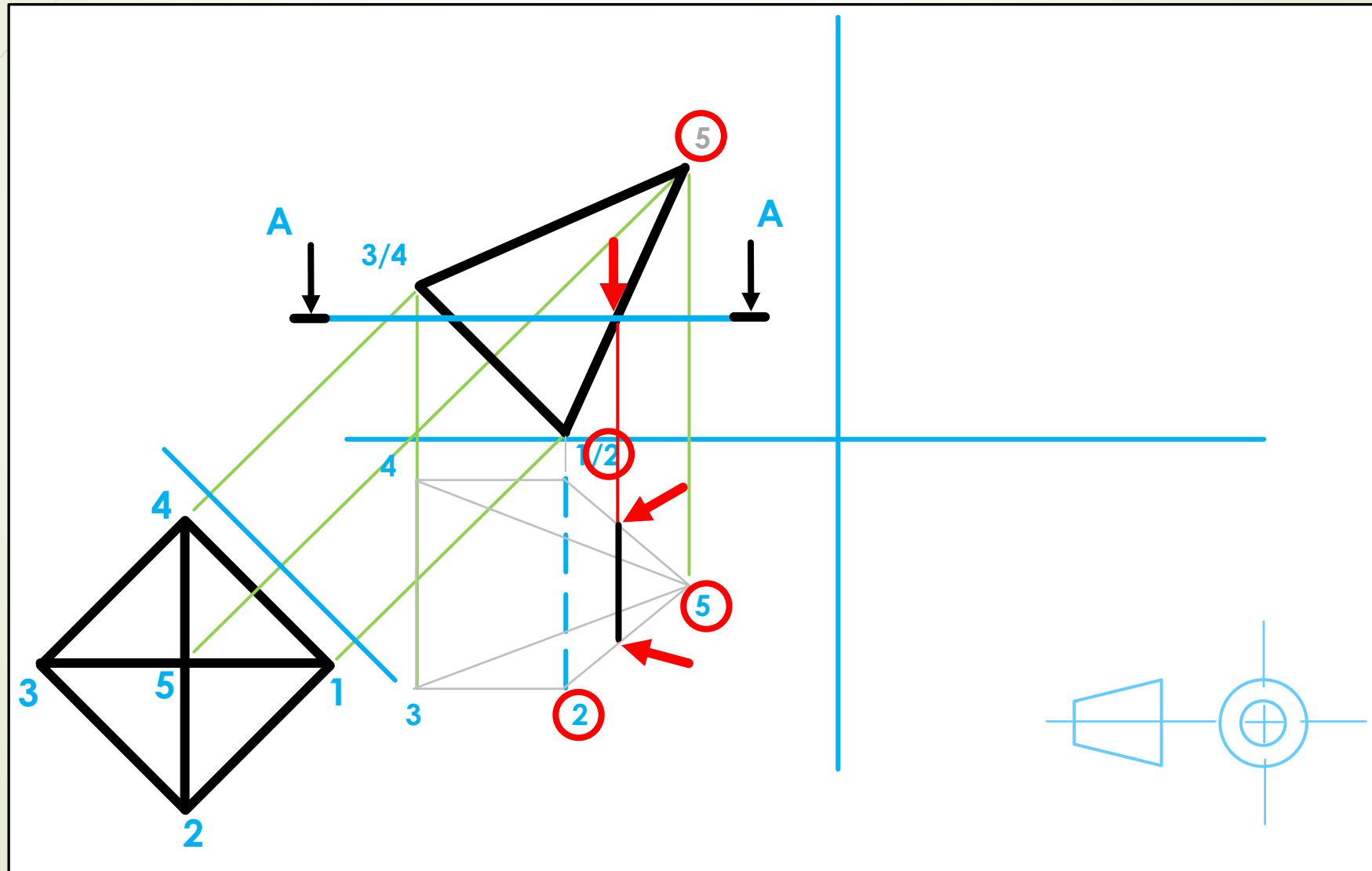

# Application on pyramids, prisms, cones and cylinders

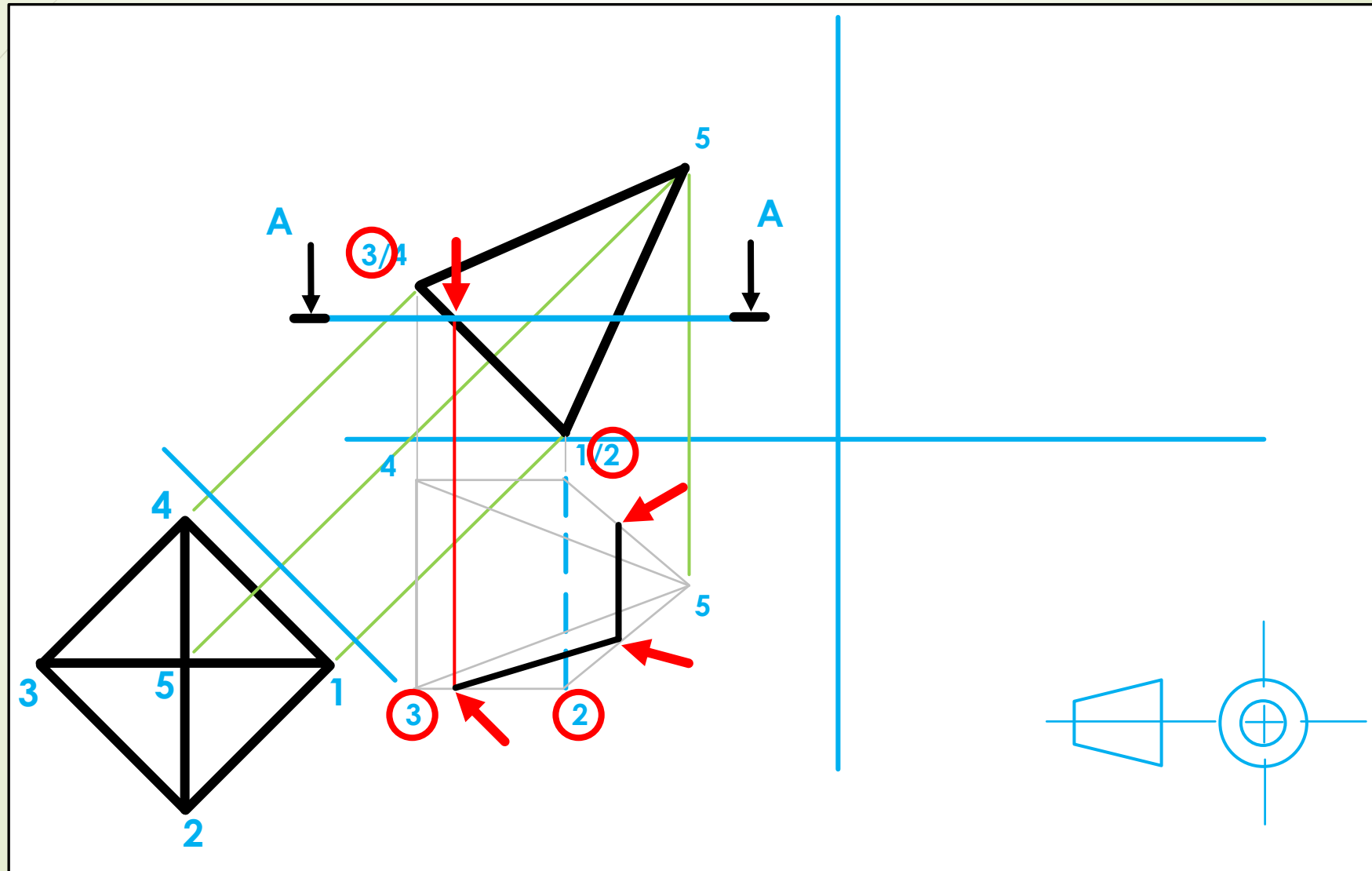
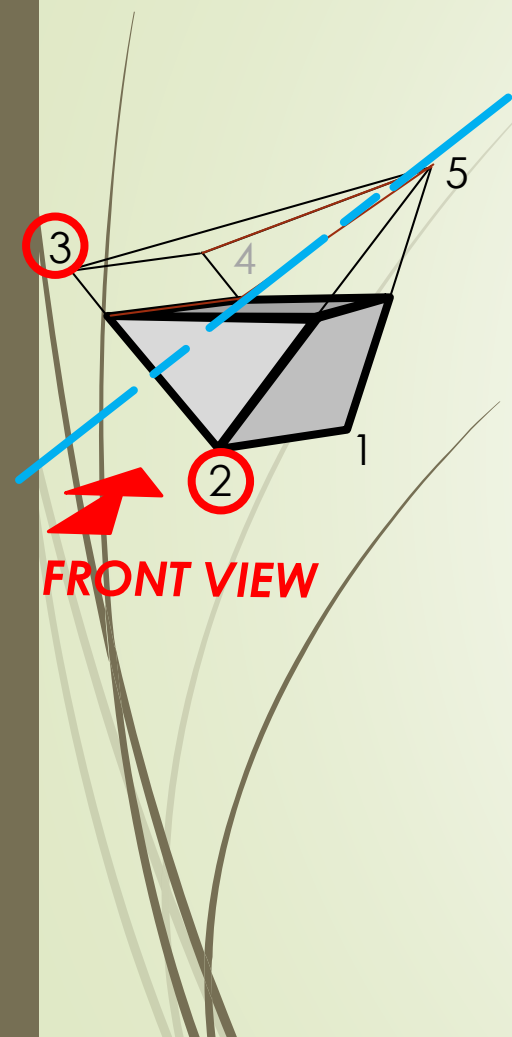



# Application on pyramids, prisms, cones and cylinders

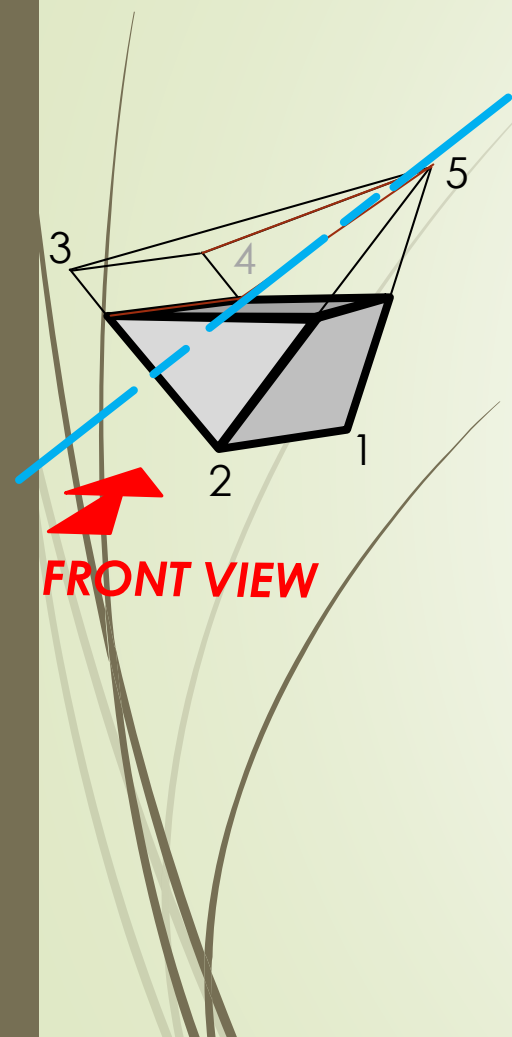

**FRONT VIEW**

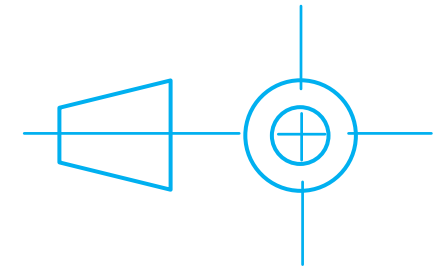
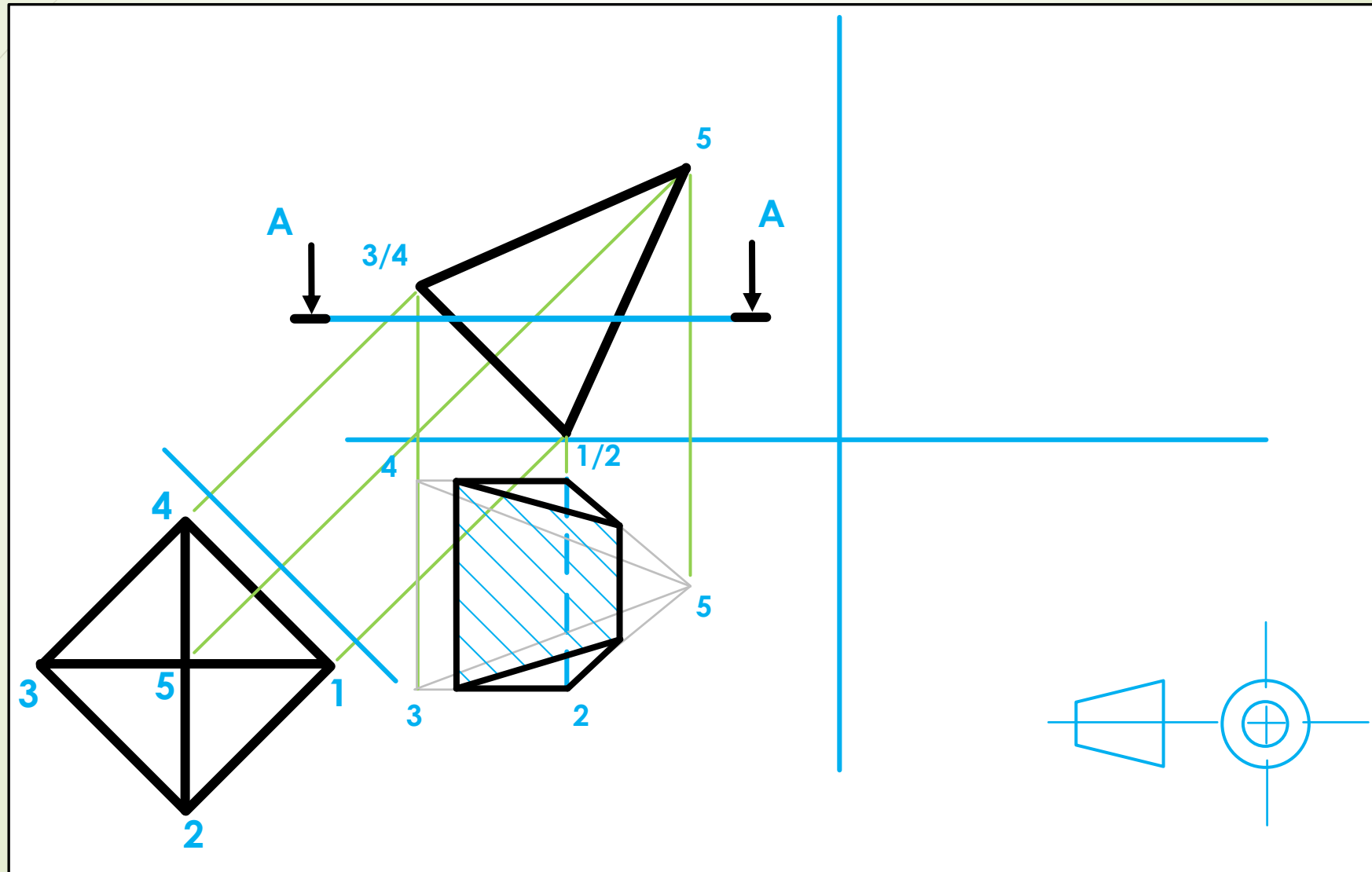

# Application on pyramids, prisms, cones and cylinders

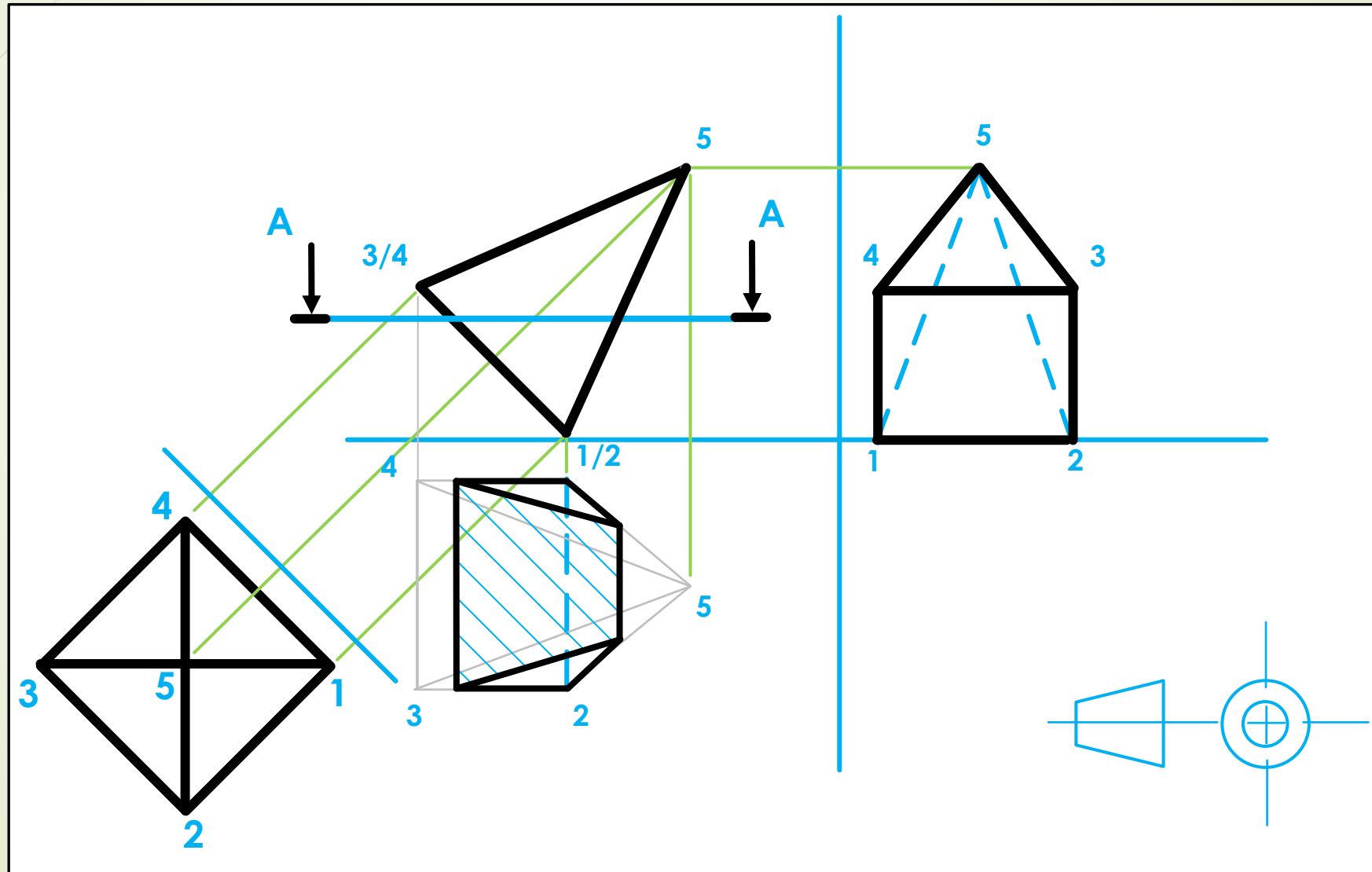
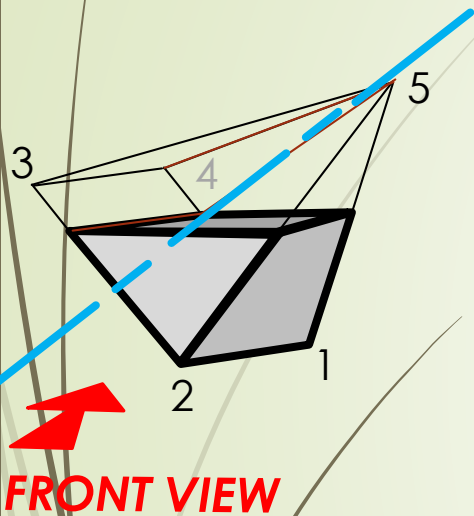

# Application on pyramids, prisms, cones and cylinders

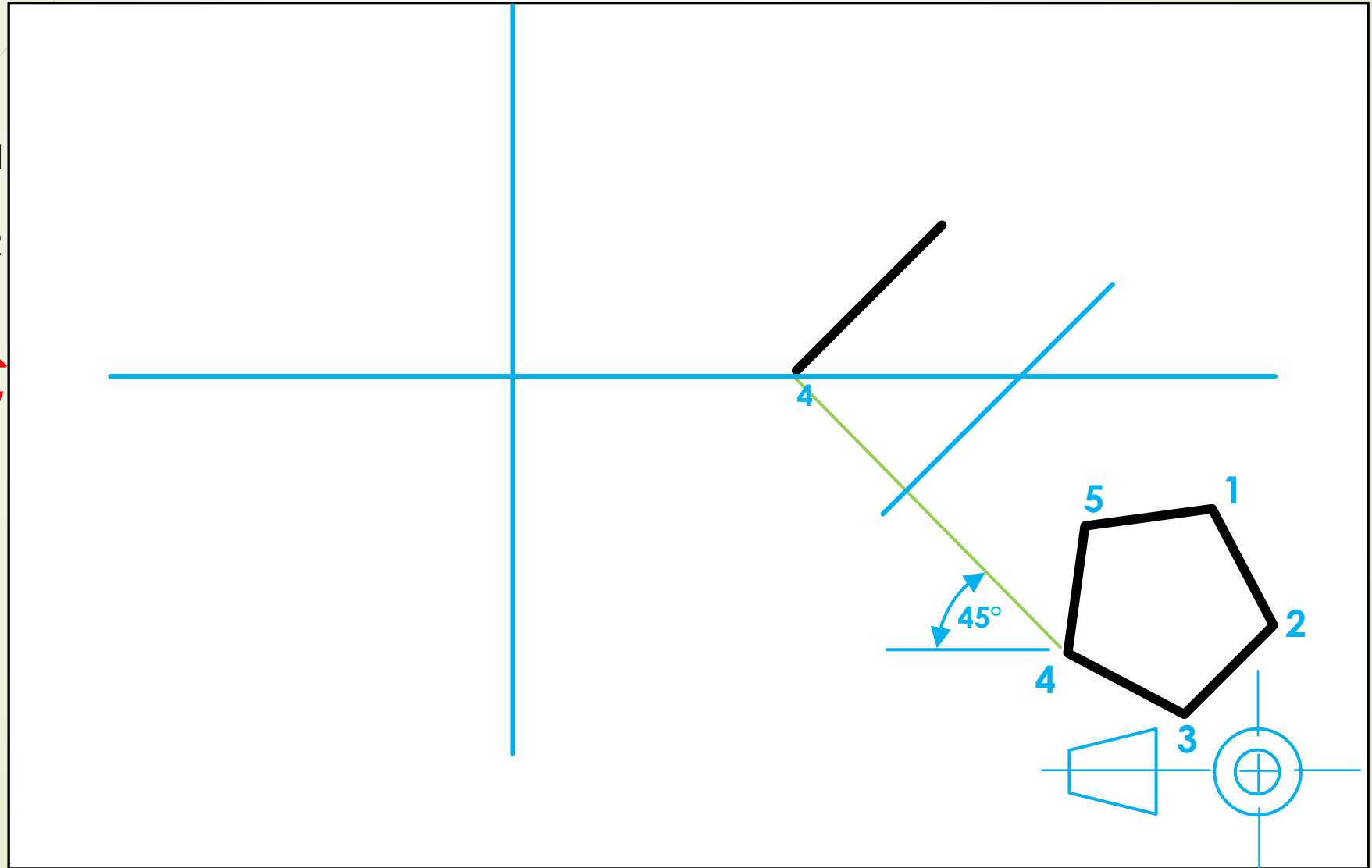
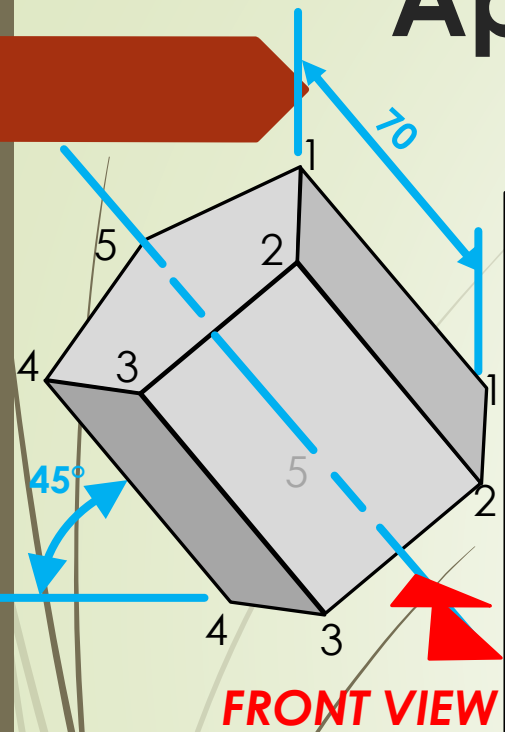

# Application on pyramids, prisms, cones and cylinders

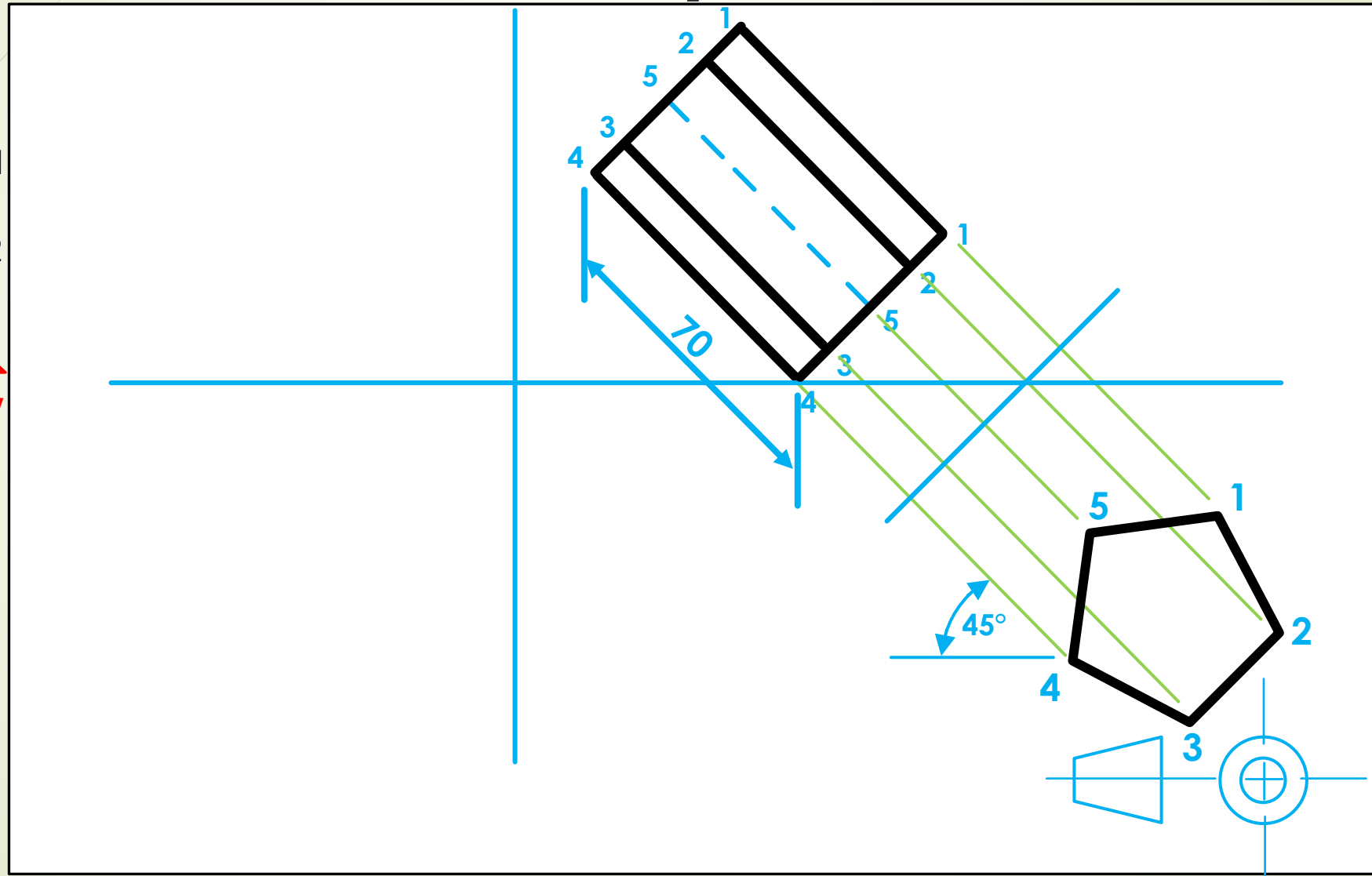
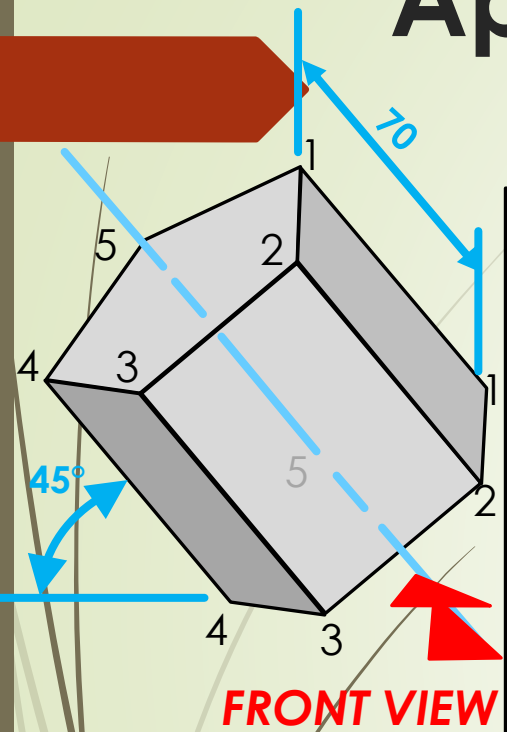

# Application on pyramids, prisms, cones and cylinders

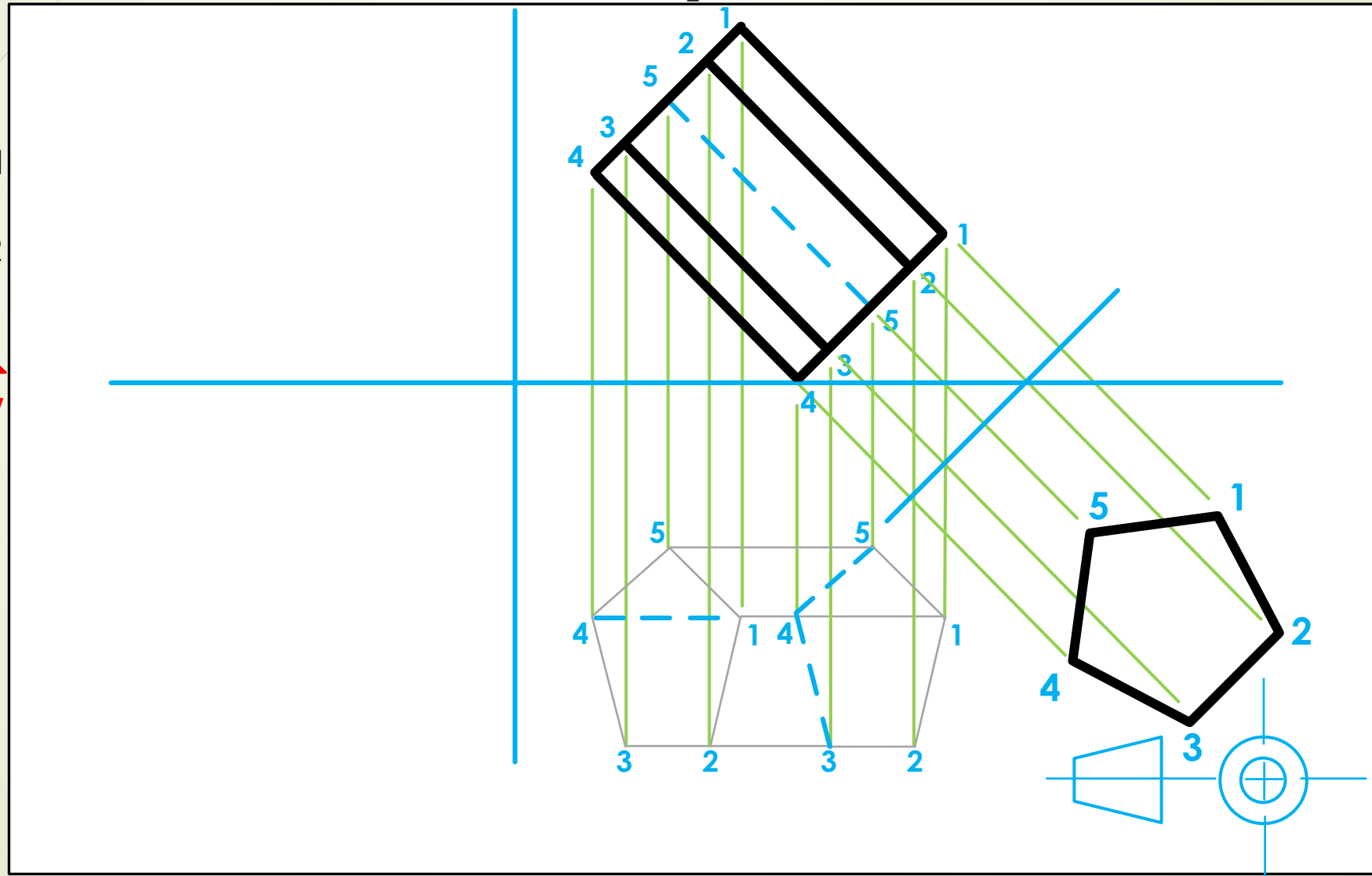
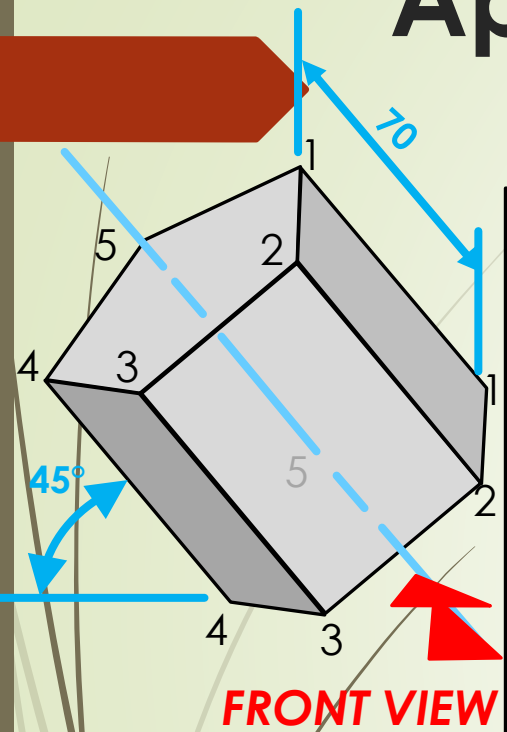

# Application on pyramids, prisms, cones and cylinders

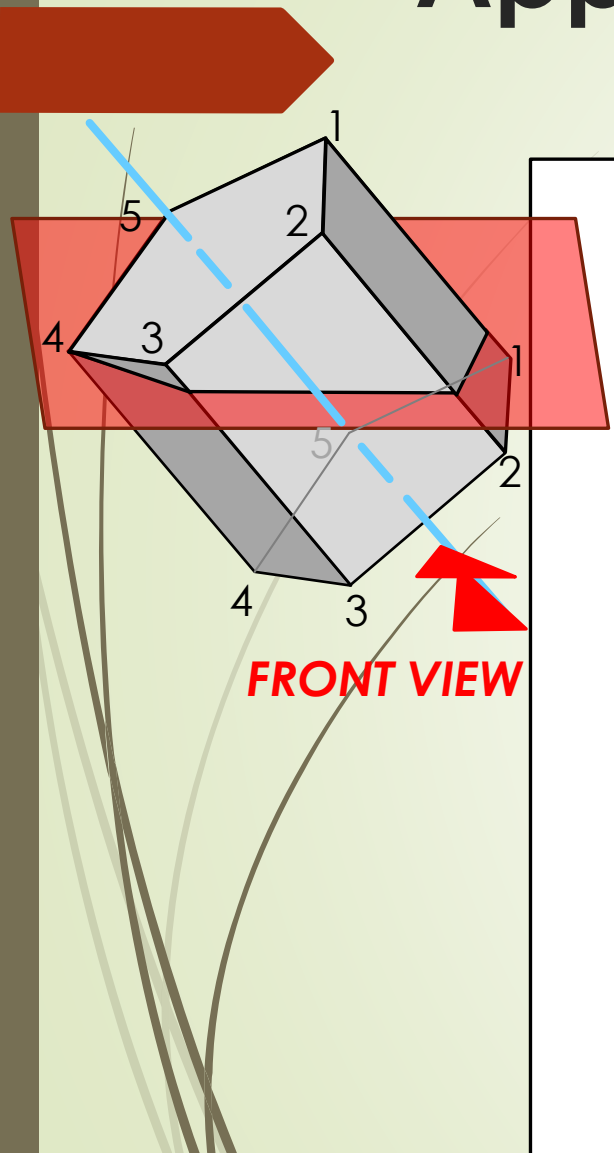

**FRONT VIEW**

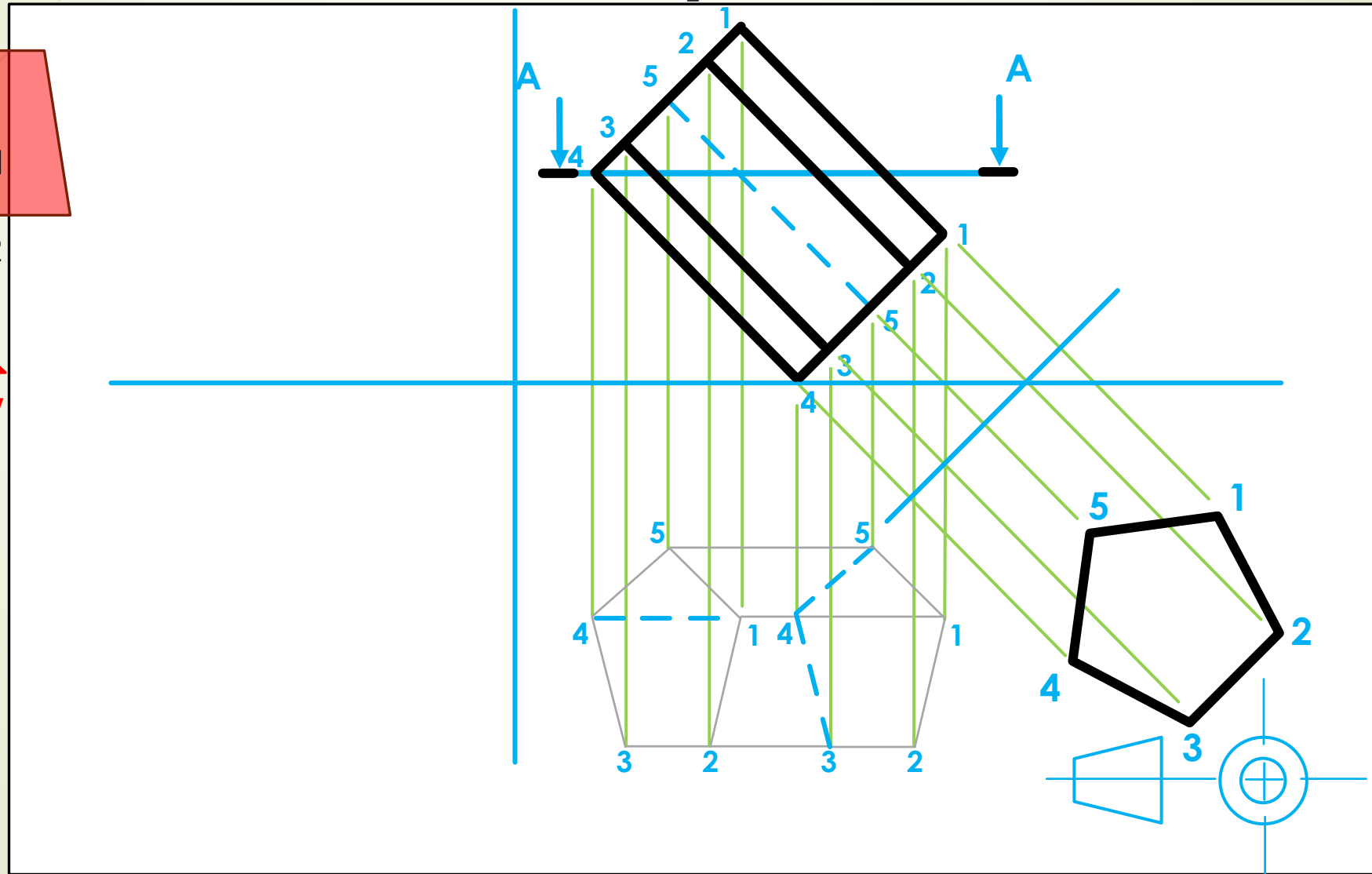

# Application on pyramids, prisms, cones and cylinders

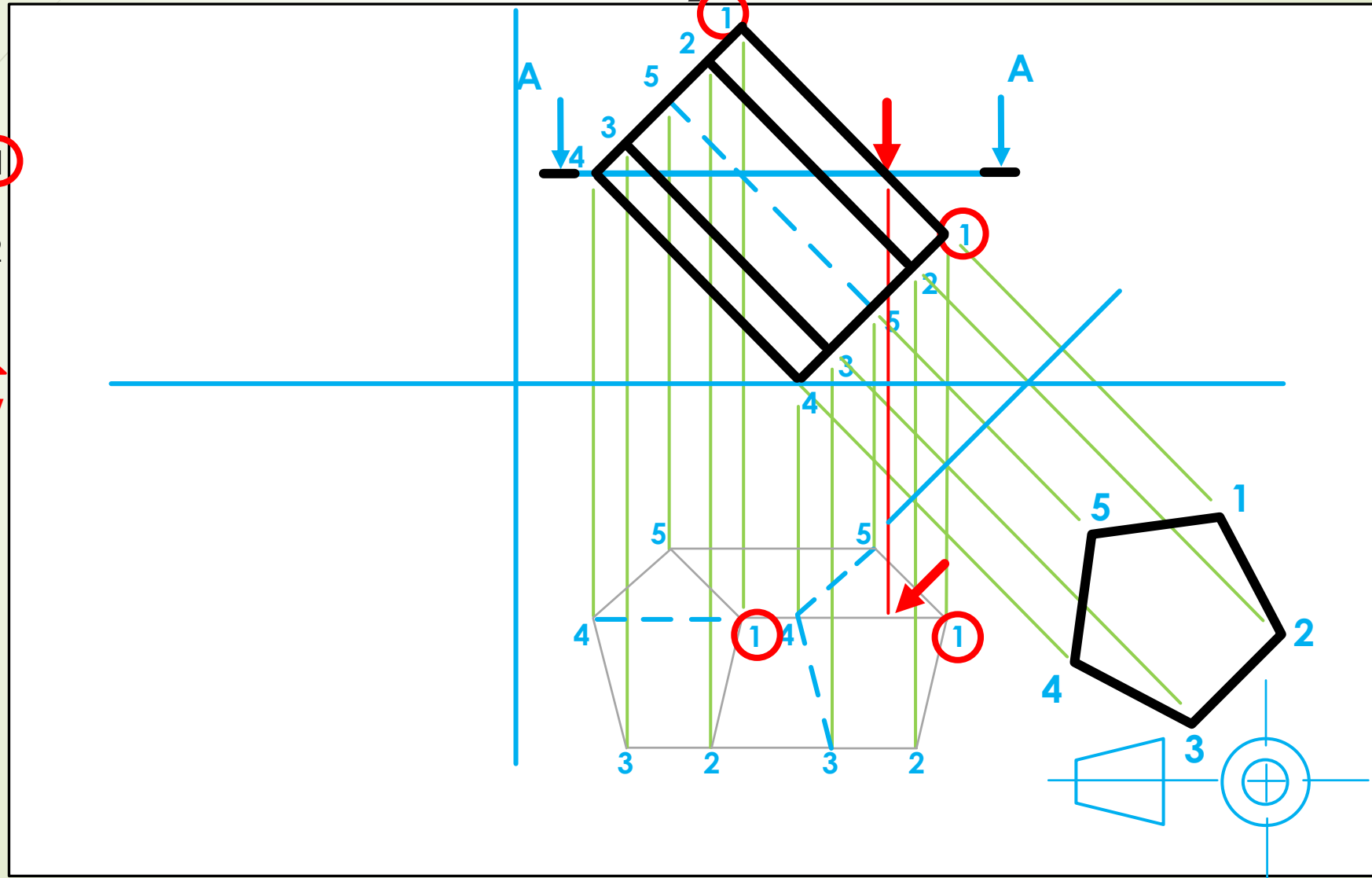
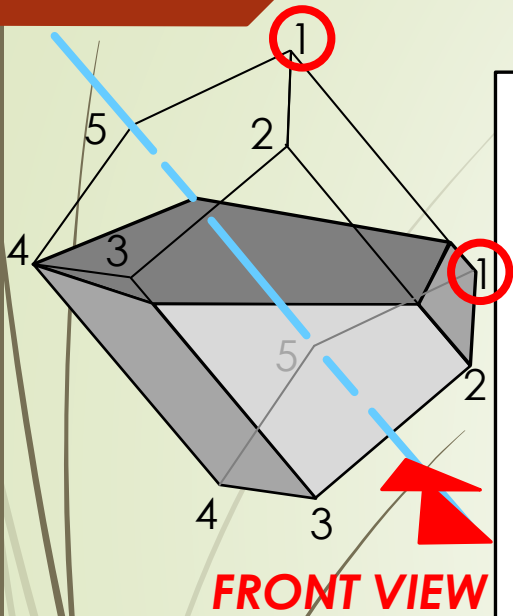

# Application on pyramids, prisms, cones and cylinders

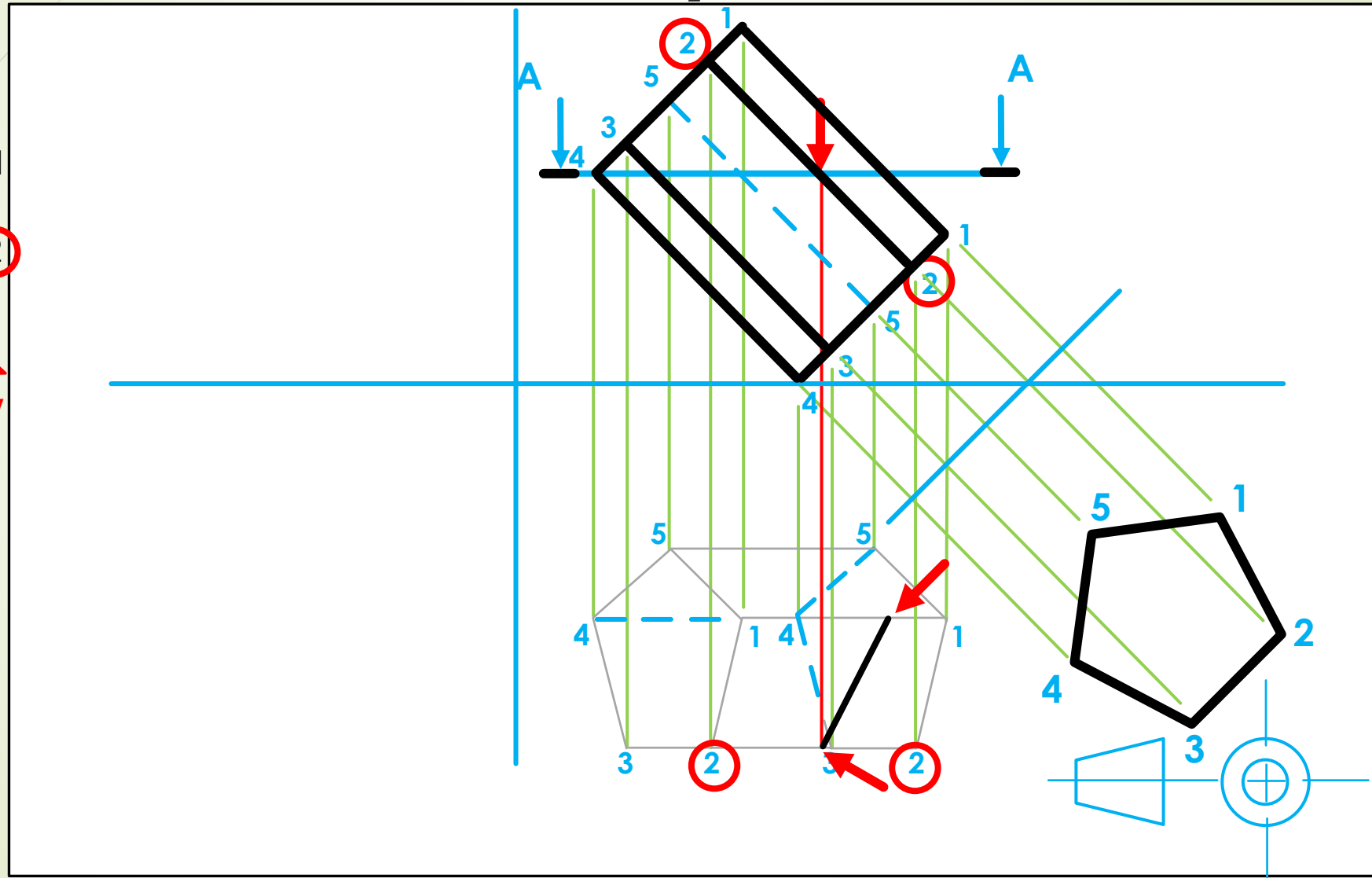
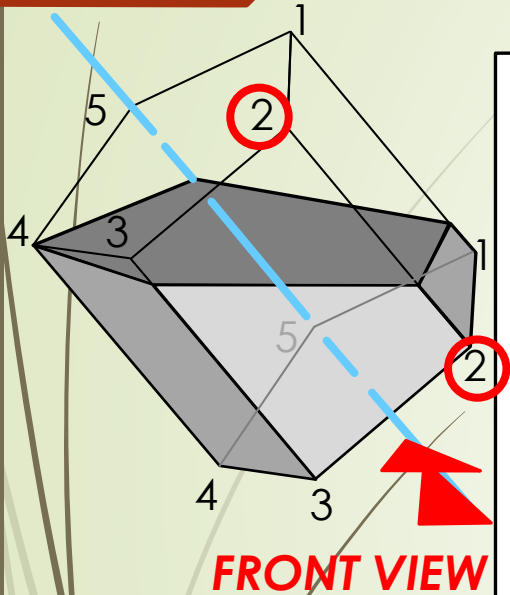





# Application on pyramids, prisms, cones and cylinders

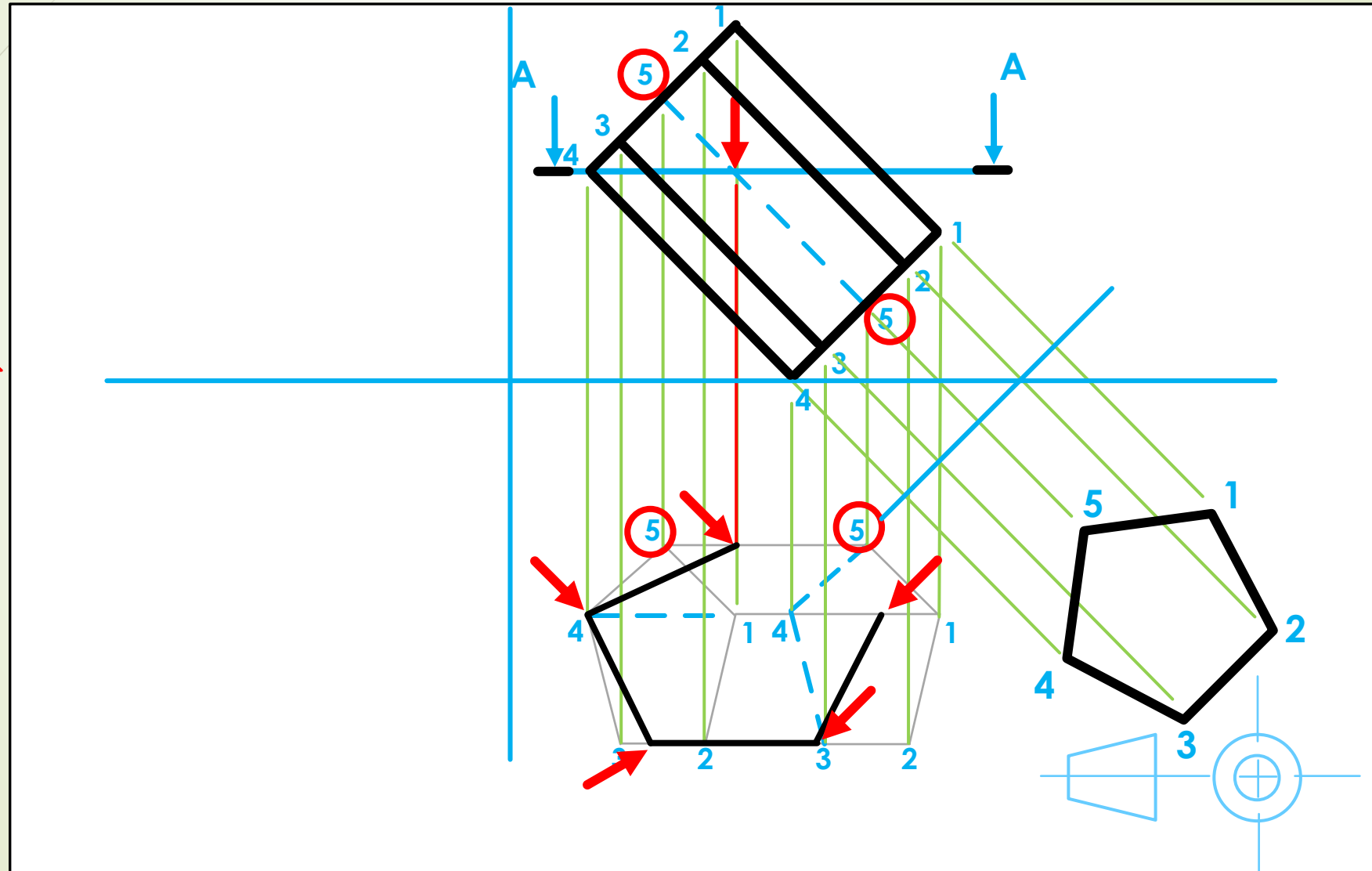
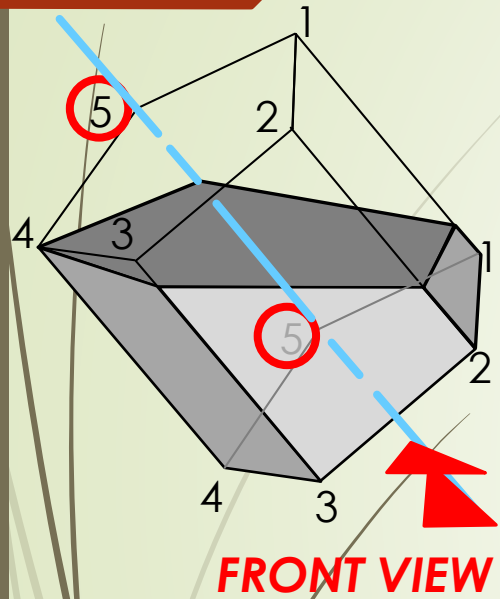

# Application on pyramids, prisms, cones and cylinders

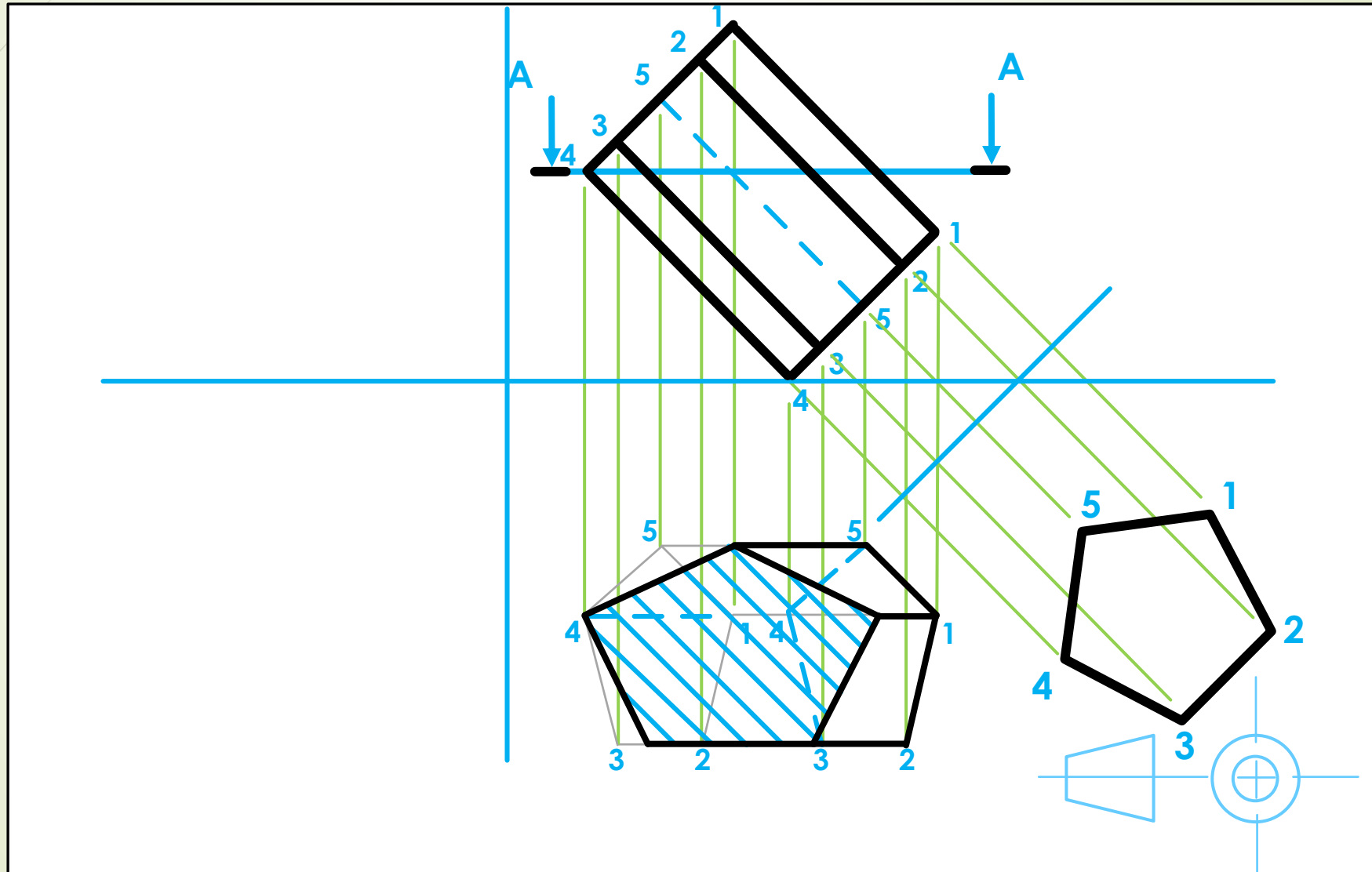
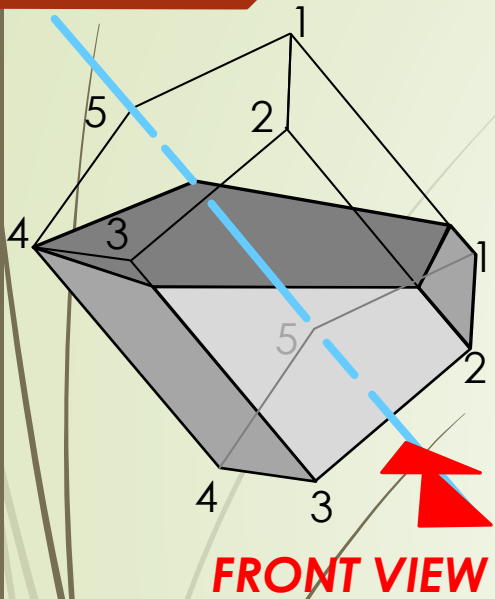

# Application on pyramids, prisms, cones and cylinders

