



2-Point-Perspective Drawing

Principles

Grade 11 & 12

Developed by: PC Viljoen
Senior Educational Specialist for
Engineering Graphics and Design
Free State Province

2-Point-Perspective Drawing

- Two-Point-Perspective is used to illustrate a rotated object at an angle to the picture plane.
- Two-Point-Perspective drawing form part of paper 1 question 3.
- Two-point-perspective uses two sets of vanishing points to draw an object.
- Vanishing Points are two points on a level whereto the drawing seem to converge and disappear.

2-Point-Perspective Drawing

Question

► The standard question for a perspective drawing will be:

QUESTION 3: PERSPECTIVE

Given:

Three views of a shelter with a viewing deck and the information needed to draw a two-point perspective drawing

PP – Picture plane

HL – Horizon line

GL – Ground line

SP – Station point

Instructions:

Complete the perspective drawing.

- Align the drawing sheet with the ground line (GL).
- Determine and label the vanishing points.
- Show ALL necessary construction.
- **NO** hidden detail is required.

[40]

2-Point-Perspective Drawing

Question

QUESTION 3: PERSPECTIVE

Given:

Three views of a shelter with a viewing deck and the information needed to draw a two-point perspective drawing

PP – Picture plane

HL – Horizon line

GL – Ground line

SP – Station point

Instructions:

Complete the perspective drawing.

- Align the drawing sheet with the ground line (GL).
- Determine and label the vanishing points.
- Show ALL necessary construction.
- NO hidden detail is required. [40]

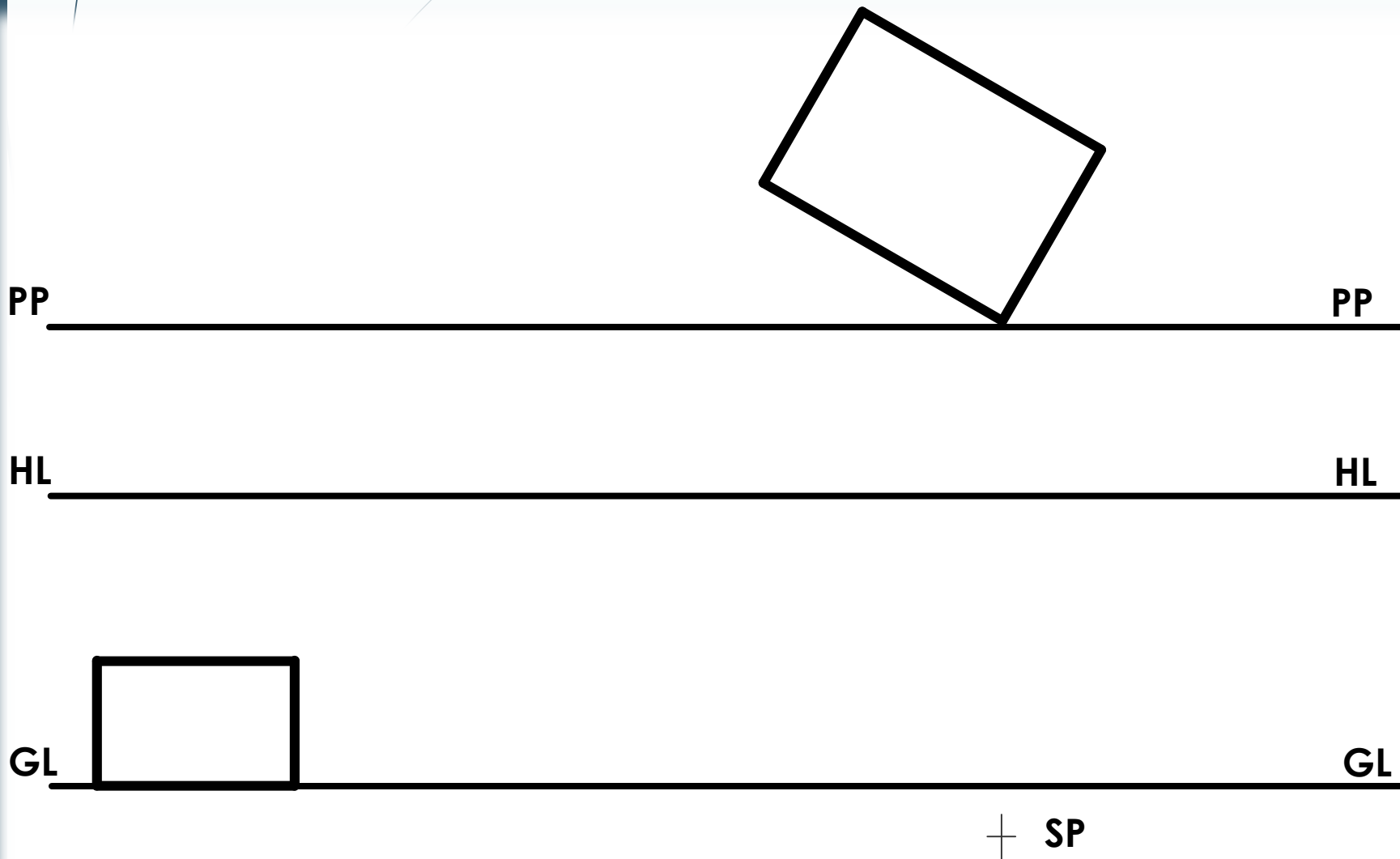

education

Department of
Education
FREE STATE PROVINCE

2-Point-Perspective Drawing

Step 1

- Determine the left vanishing point & name it **LVP**.

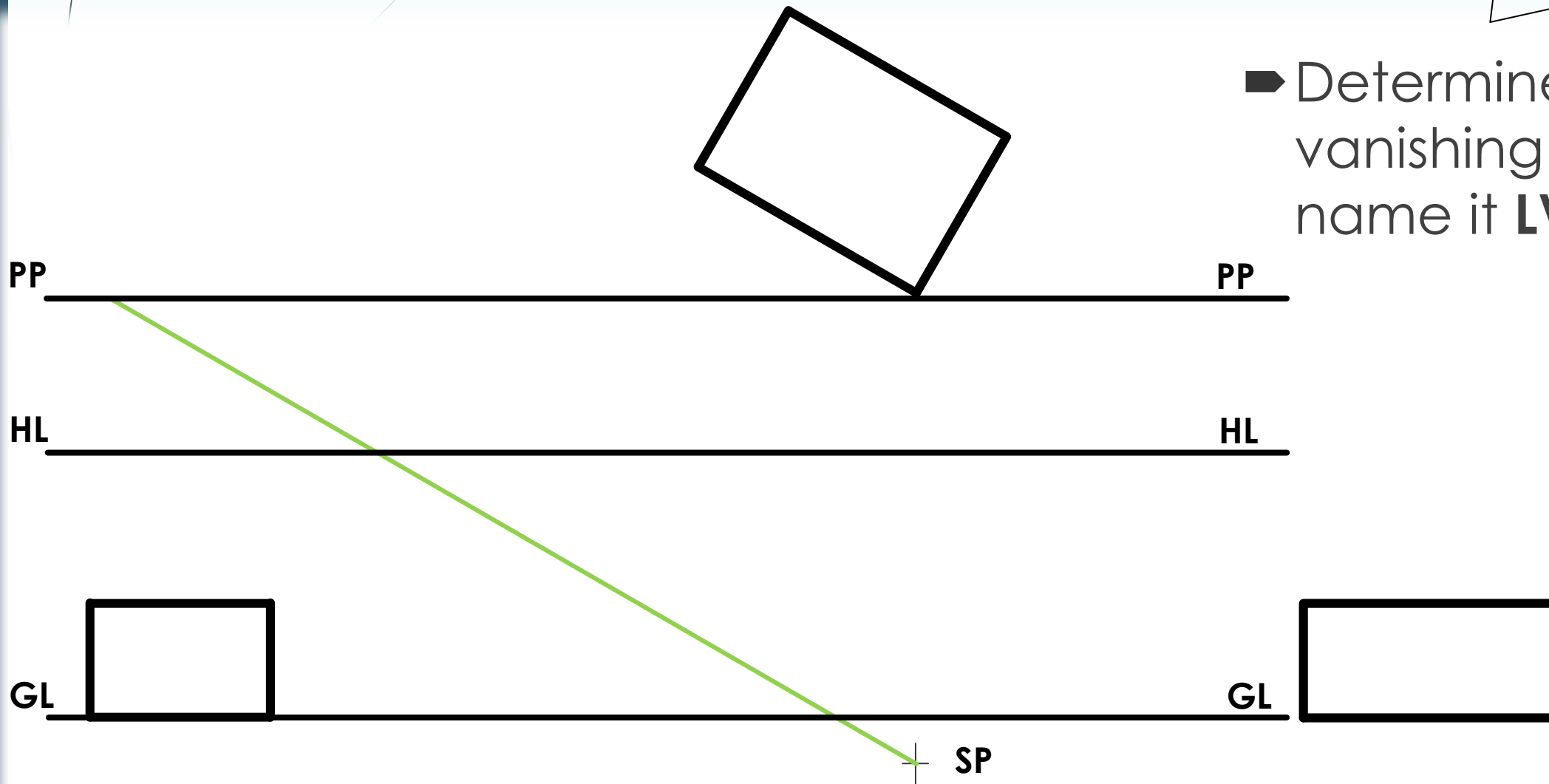

2-Point-Perspective Drawing

Step 2

- Determine the left vanishing point & name it **LVP**.

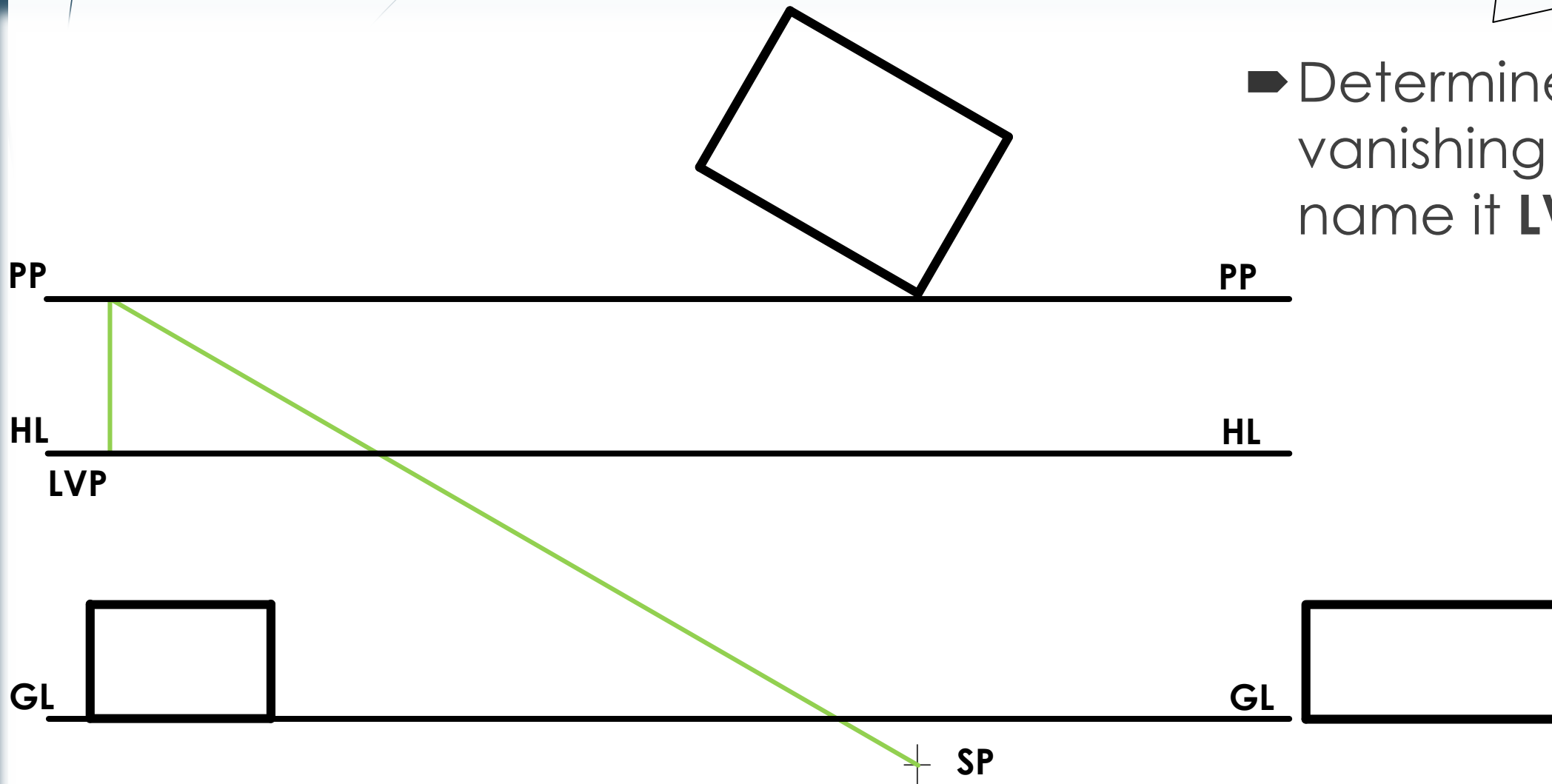

2-Point-Perspective Drawing

Step 3

- Determine the right vanishing point & name it **RVP**.

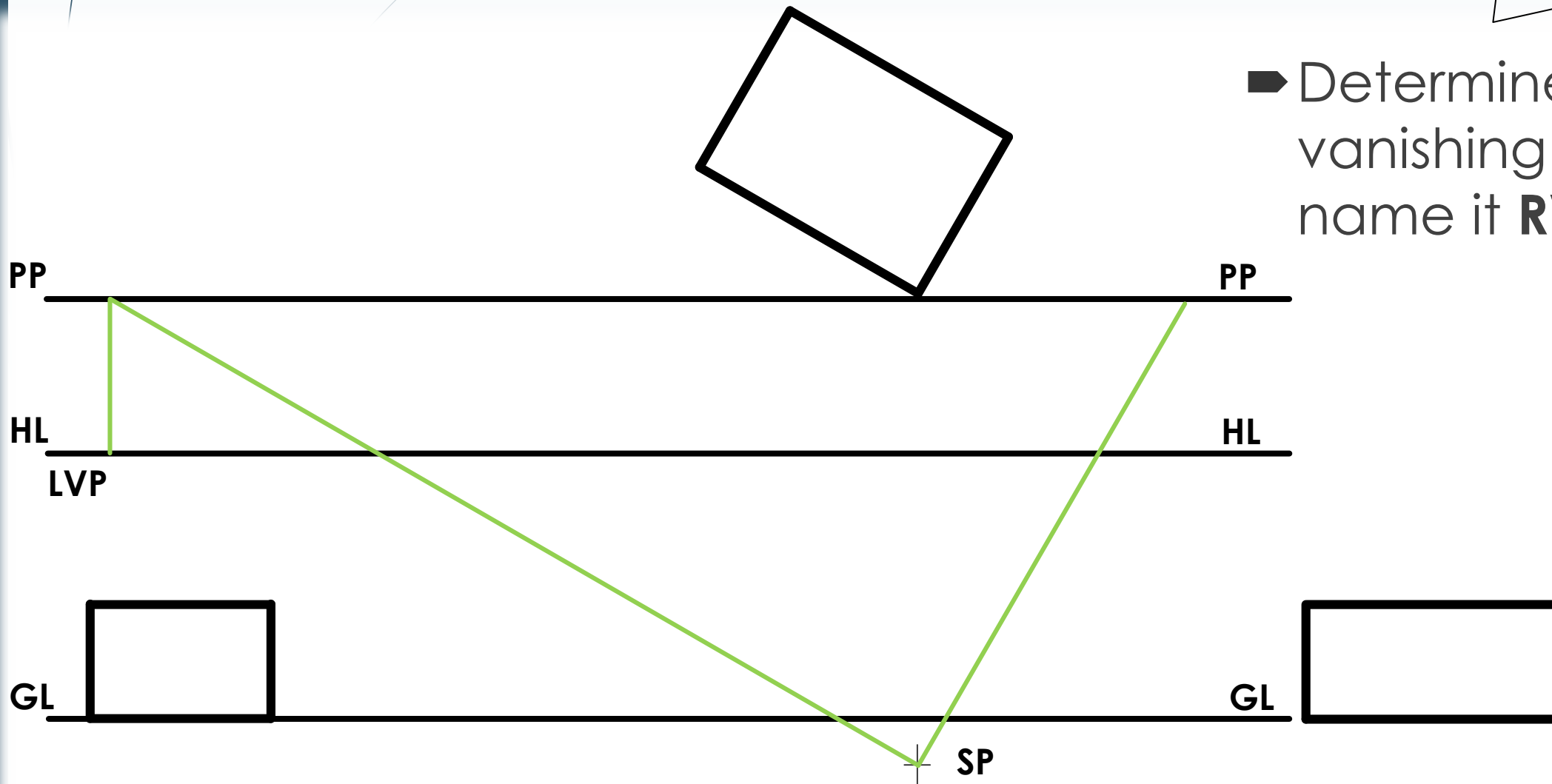

2-Point-Perspective Drawing

Step 4

- Determine the right vanishing point & name it **RVP**.

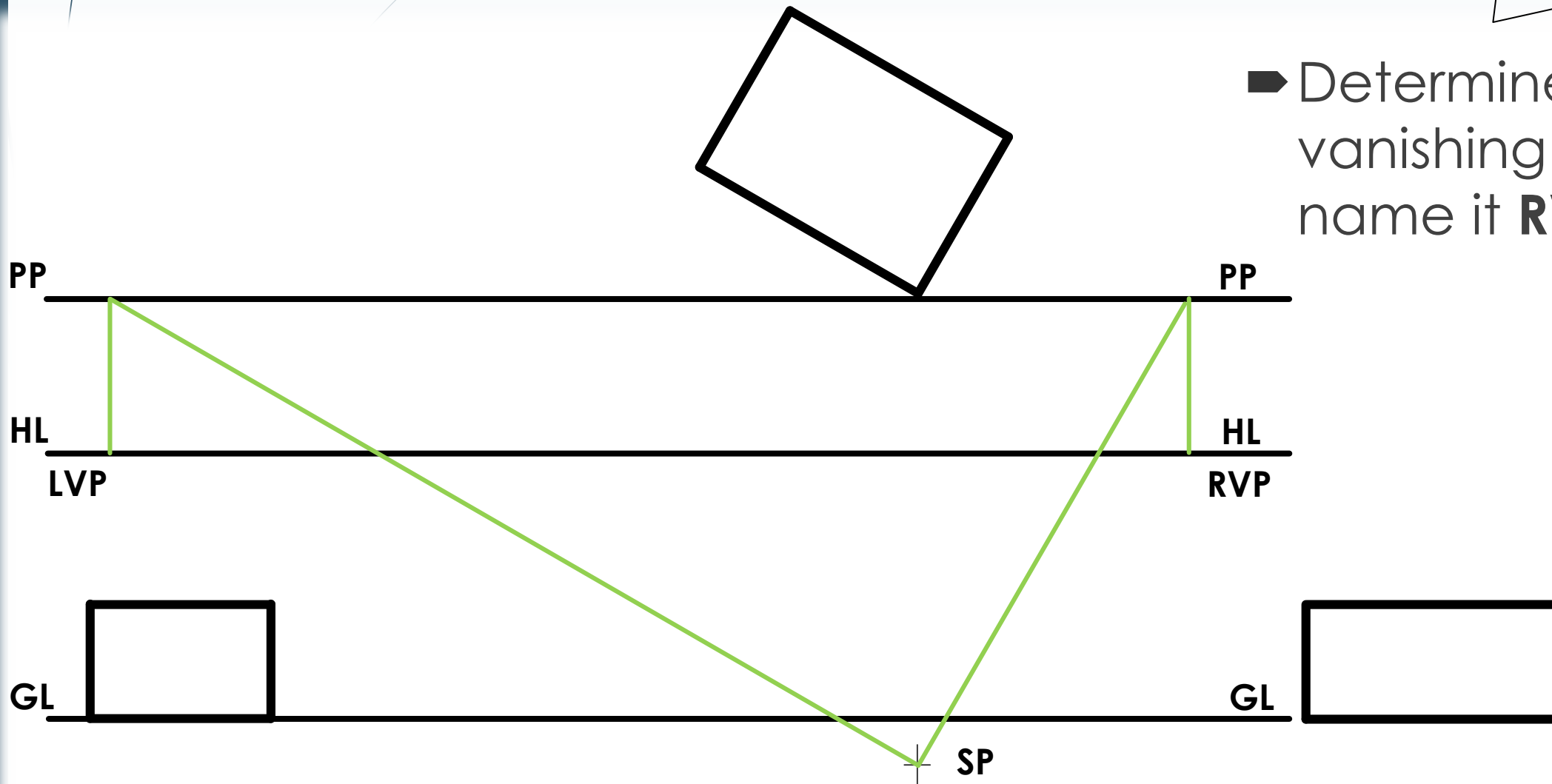

2-Point-Perspective Drawing

Step 6

- Extend the base of the drawing towards both vanishing points

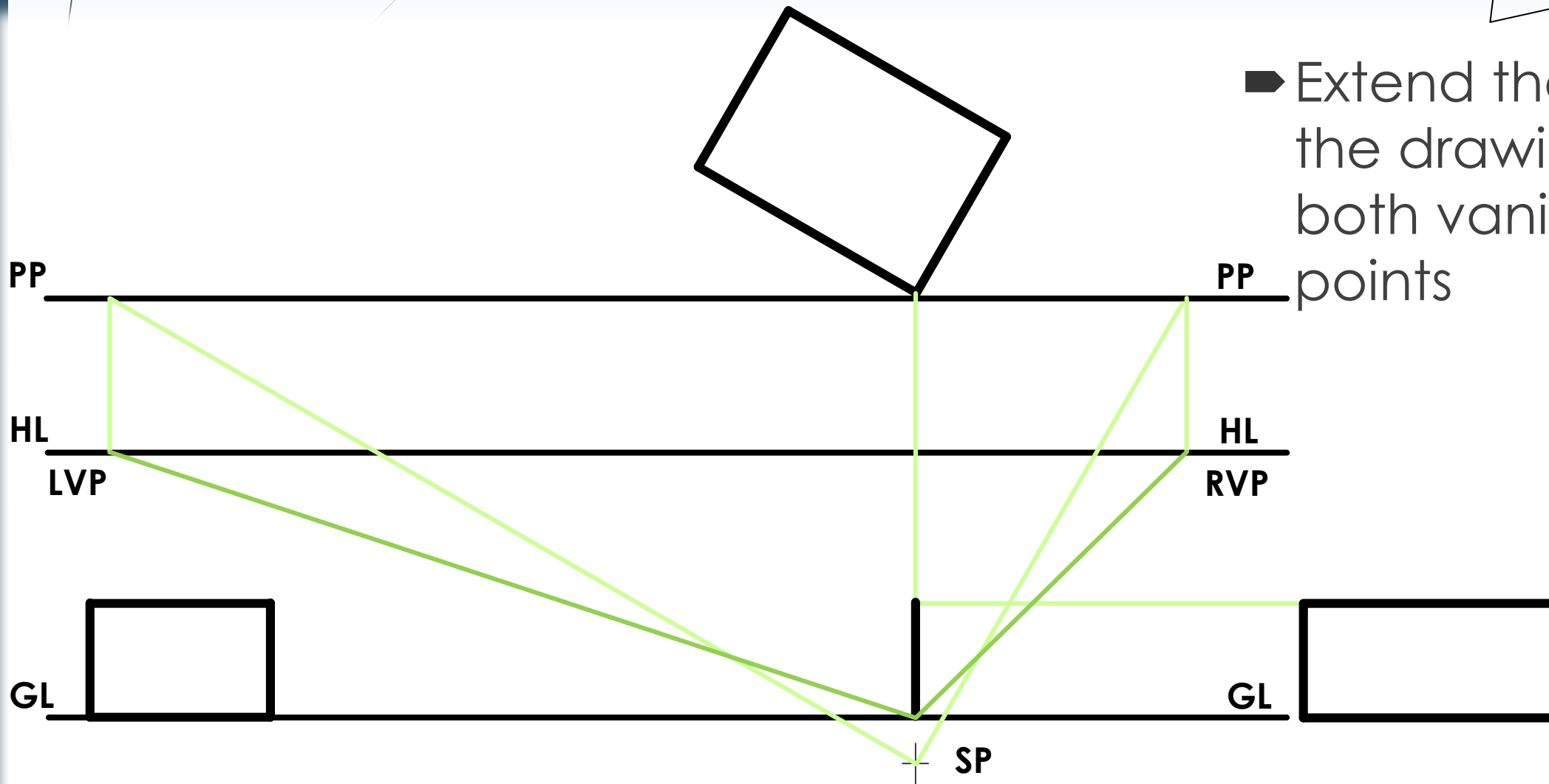

2-Point-Perspective Drawing

Step 7

- Determine the bottom left endpoint of the drawing.

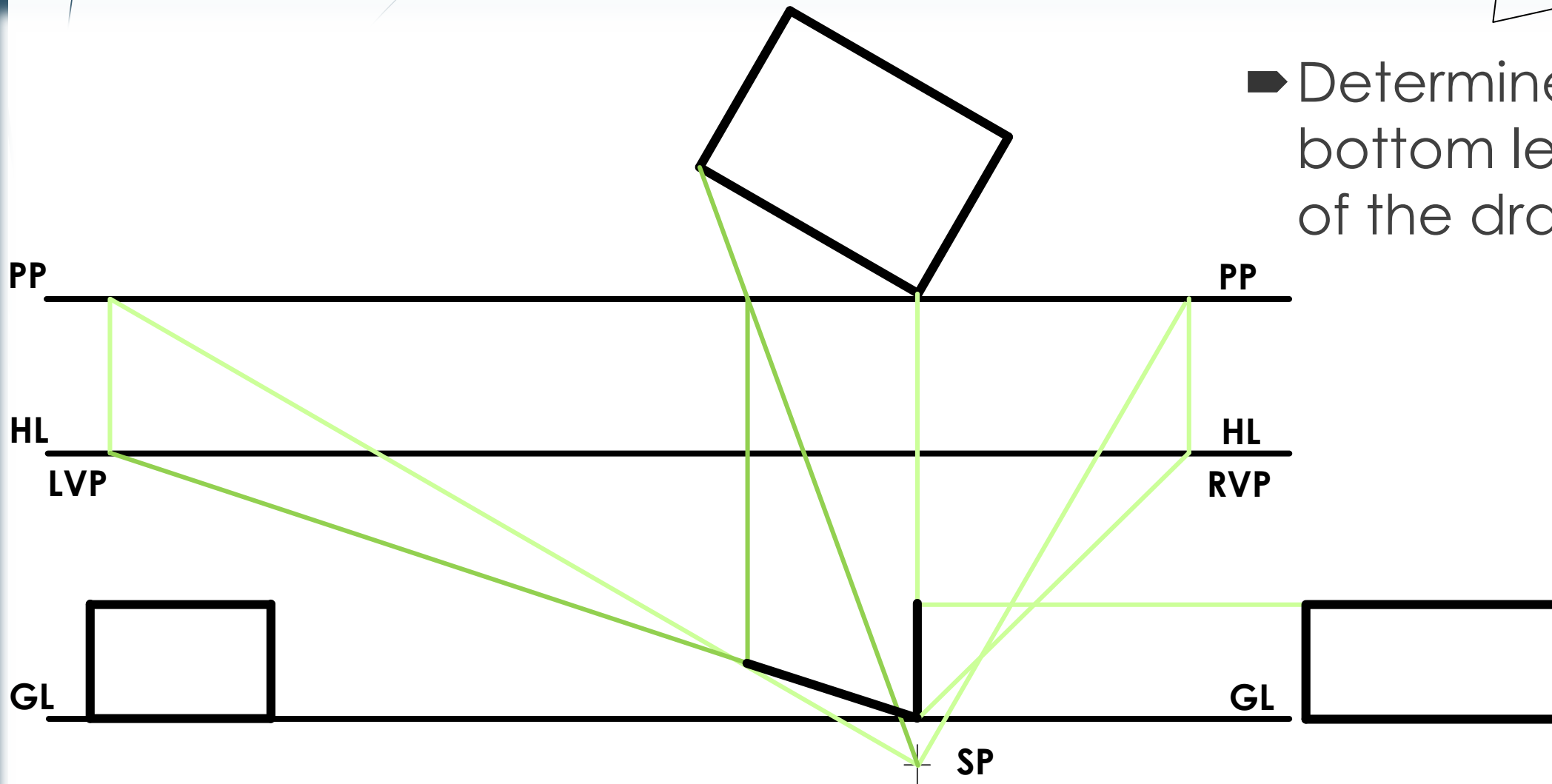

2-Point-Perspective Drawing

Step 10

- Determine the top right endpoint of the drawing.

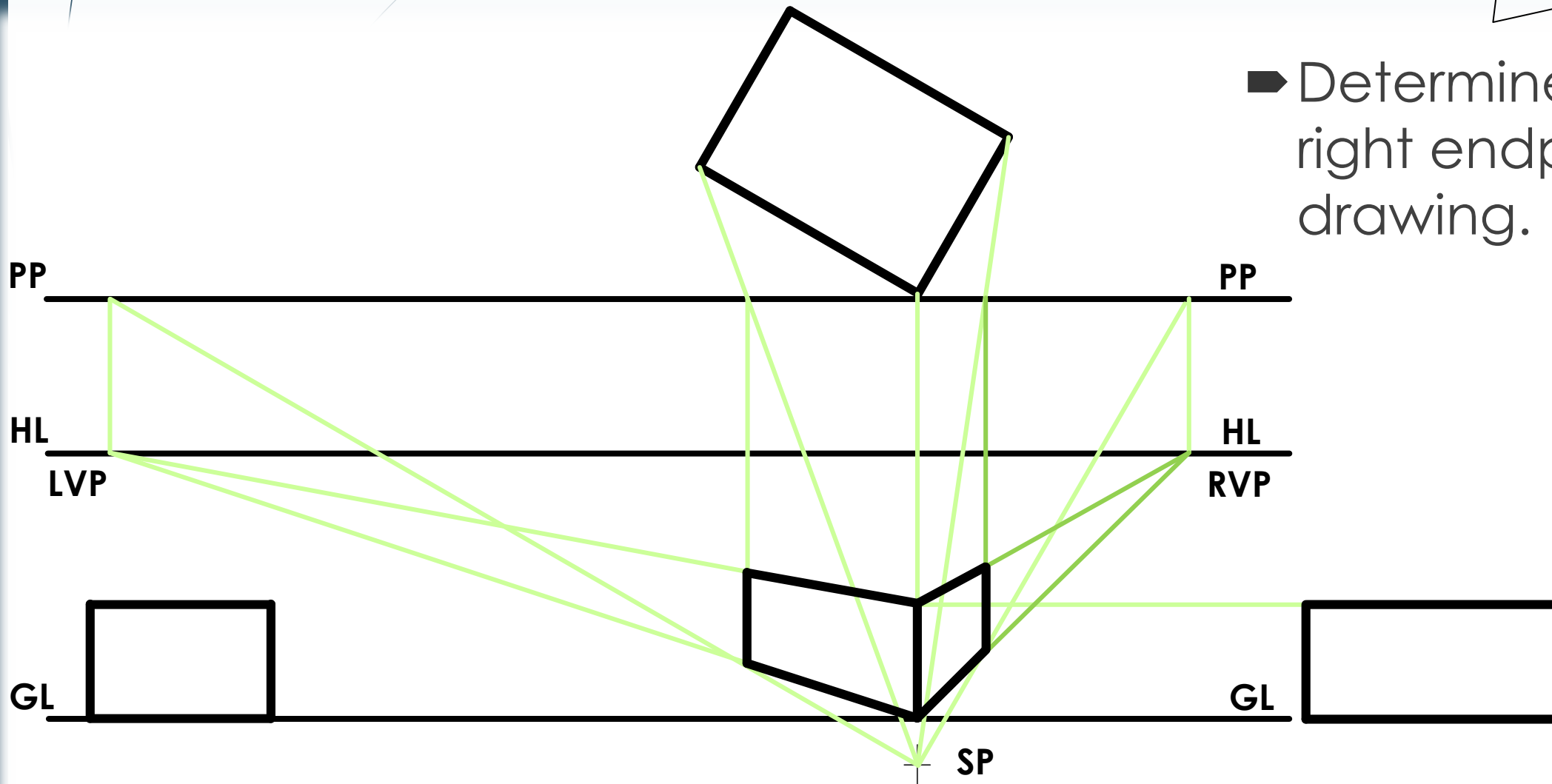

2-Point-Perspective Drawing

Step 11

➡ Complete the drawing.

