

DOOR AND WINDOW SCHEDULE

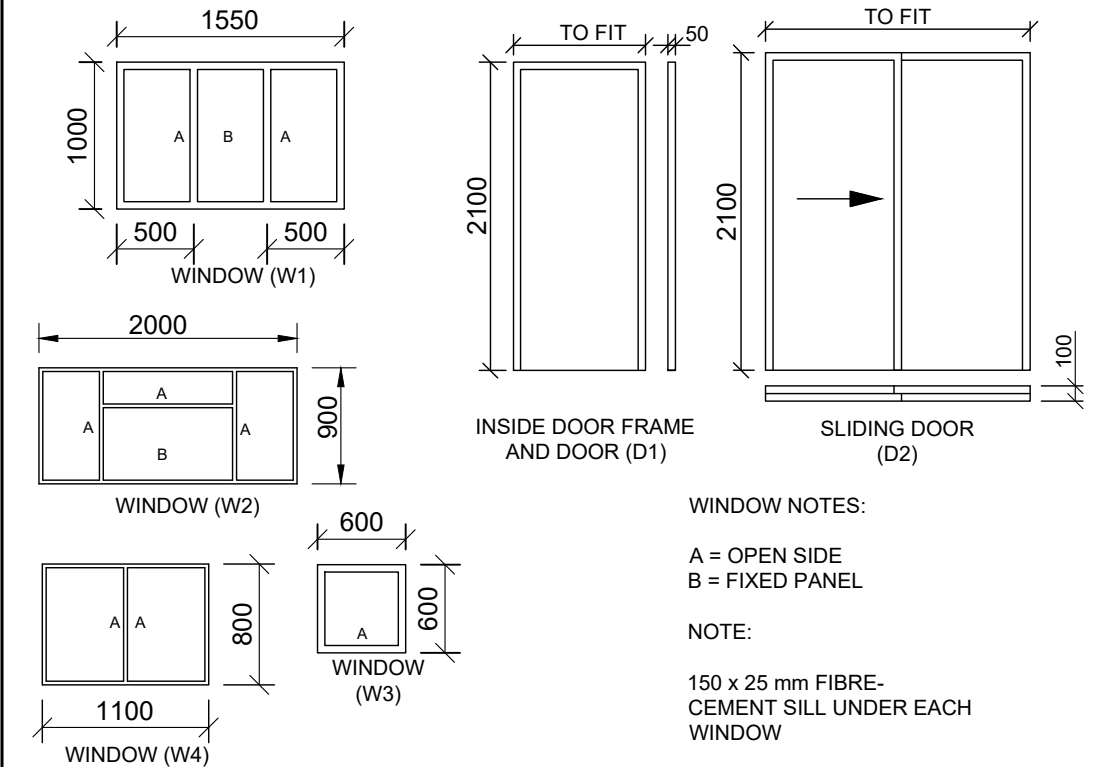

FIXTURES

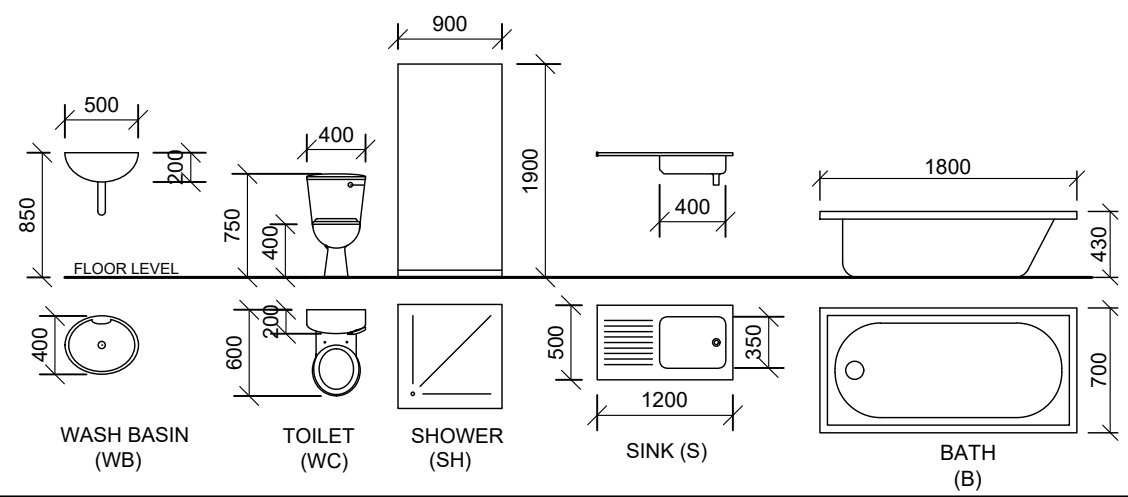

ROOM DESCRIPTIONS	FIXTURES
A. KITCHEN	TILE
B. LIVING ROOM	WOOD
C. BEDROOM 1	CARPET
D. BATHROOM	TILES
E. BEDROOM 2	CARPET
	SH Shower
	WB Wash-Basin
	WC Toilet
	S Sink
	BIC built in cabinet

QUESTION 4: CIVIL DRAWING

Given:

- The incomplete floor plan of a house showing the outlines of the common brick walls and the positions of all the features, relevant notes and dimensions.
- A table of electrical symbols.
- A door and window schedule.
- Detailed drawings of all the sanitary fixtures.
- According to scale 1:40, the outlines of the floor plan of the house on the answer sheet.

Instructions:

- Answer this questions on the answer sheet.
- Use the given incomplete floor plan and complete, according to scale 1:40, the floor plan:

Specifications:

Show the following features on the drawing:

- All the walls with hatching detail.
- The doors and windows.
- The graphic symbols and abbreviations of all the sanitary fixtures as indicated on the incomplete floor plan.
- ALL the electrical features as indicated with the numbers on the incomplete floor plan.
- The room descriptions with their finishes in all of the rooms as described by the letters.
- Name the view and indicate the scale.
- Show the north symbol.

Note:

All drawings must comply with the graphic symbol and guidelines contained in SANS 10143 [61]

ELECTRICAL SCHEDULE

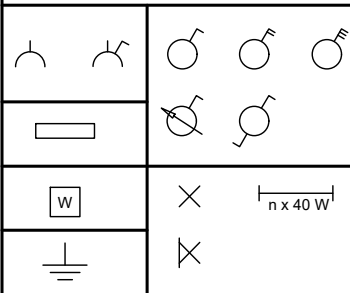

ELECTRICAL FEATURES

- Ceiling mounted light
- Wall mounted light
- 2 x 40 W Fluoresced light
- Light Switch - Single pole
- Light Switch - Double pole
- Two way switch
- Switch Socket Outlet
- Distribution board

NOTE:
 THE ARROW SHOWS THE LIGHT CONNECTION TOWARDS THE SWITCH

DOORFRAME

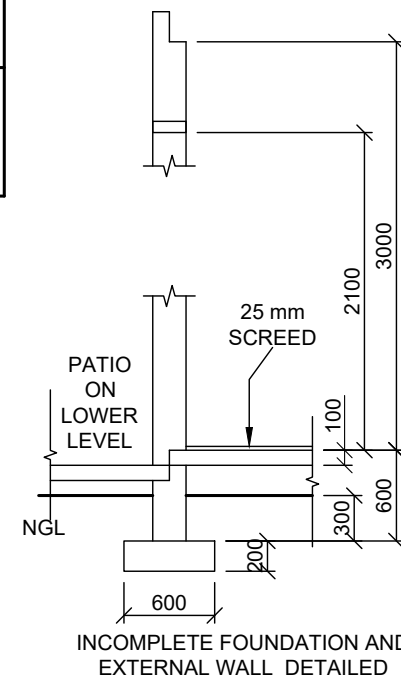
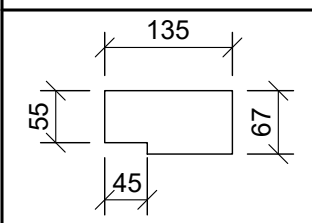

INCOMPLETE FOUNDATION AND EXTERNAL WALL DETAILED

LOAD BEARING WALLS = 200mm
 NON LOAD BEARING WALLS = 110mm

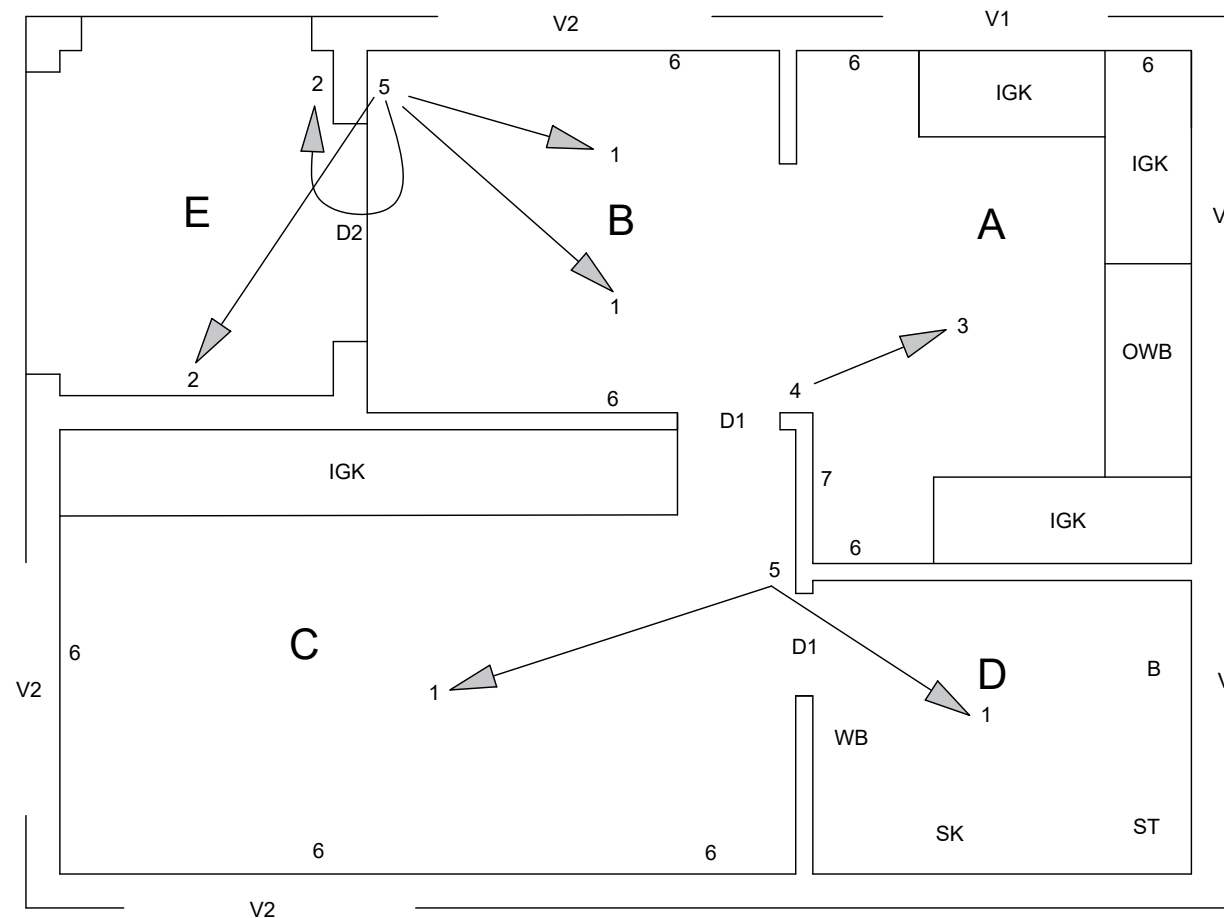

INCOMPLETE FLOOR PLAN
 SCALE 1:70



CIVIL

ESTIMATED TIME FOR COMPLETION 30 MIN
 YOUR TIME FOR COMPLETION MIN

GRADE 11

INITIALS & SURNAME

TASK 5.5
 PAGE 19

STAPEL

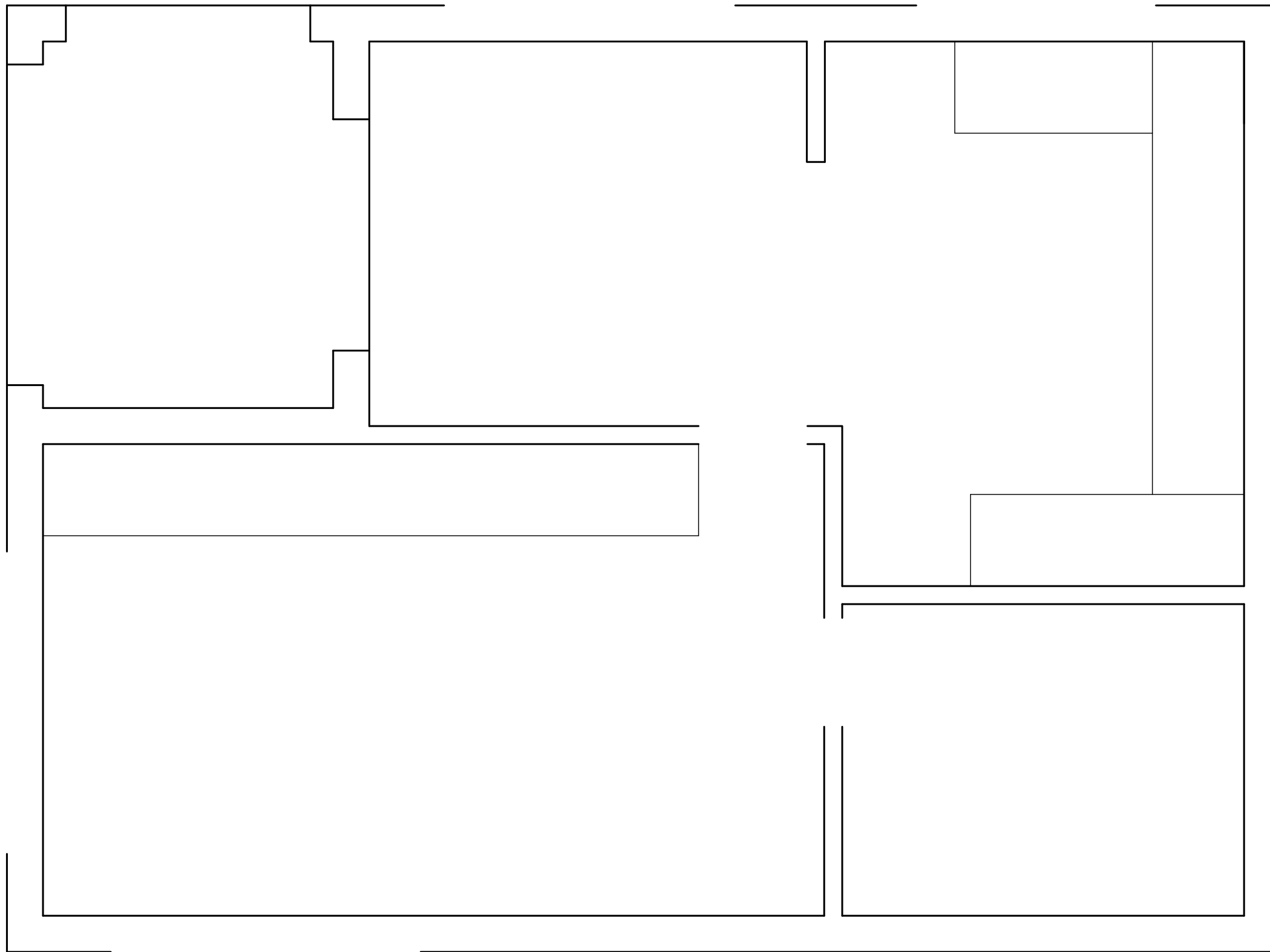

ASSESSMENT CRITERIA				
FLOOR PLAN				
1	DOORS	4		
2	WINDOWS	15		
3	FIXTURES	15		
4	ELECTRICAL	14		
5	HATCHING	6		
6	LABELS	7		
TOTAL		61		



CIVIL WORK DRAWING

ESTIMATED TIME FOR COMPLETION
YOUR TIME FOR COMPLETION

30 MIN
MIN

GRADE
11

INITIALS &
SURNAME

TASK
5.5

PAGE
20