

THE
CONSTRUCTION
INDUSTRY
CIVIL DRAWINGS
Sectioned Elevation

Developed by: PC Viljoen
Senior Educational Specialist for
Engineering Graphics and Design
Free State Province

A SECTIONAL VIEW (Grade 12 level)

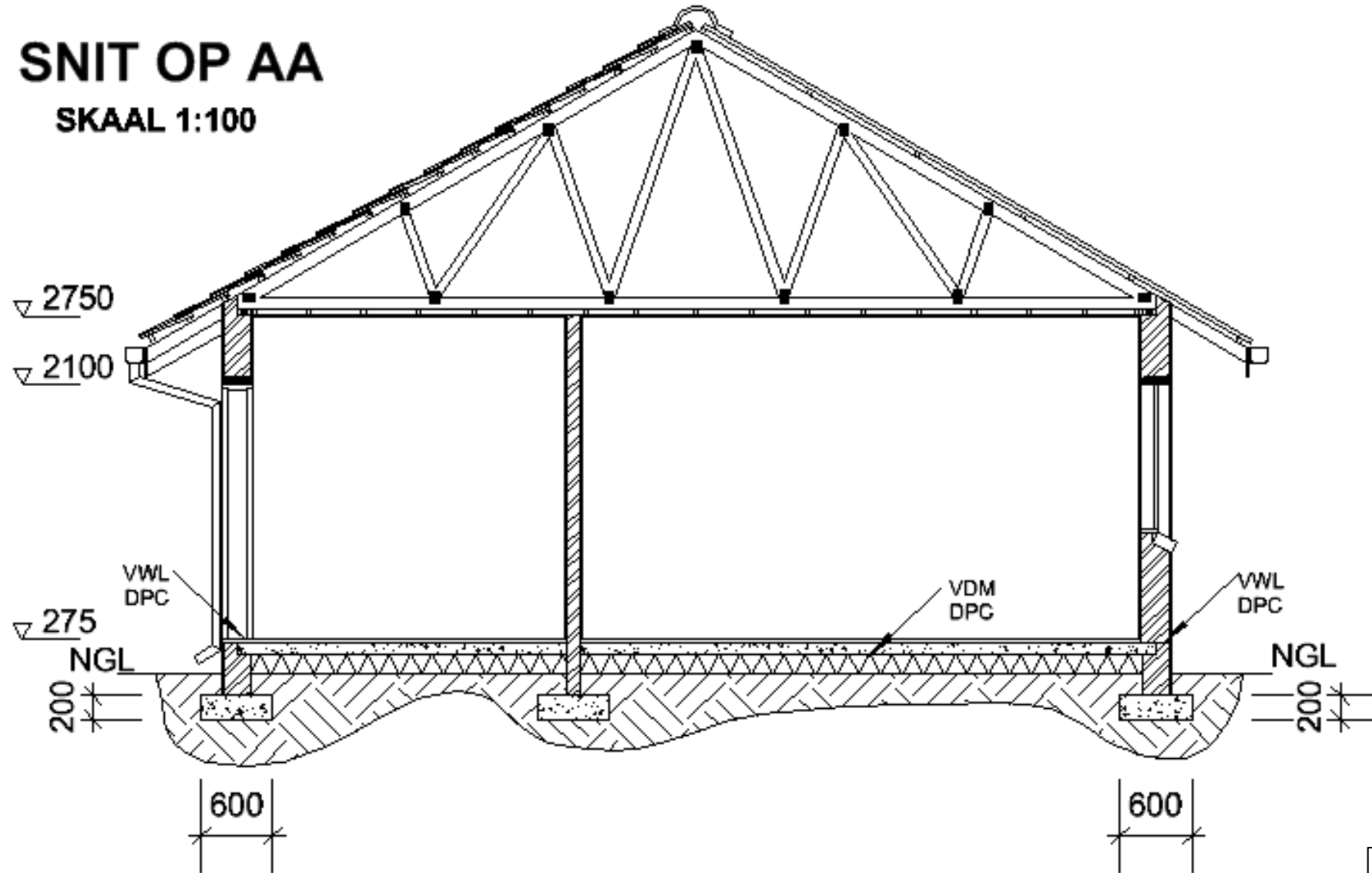

FOUNDATIONS (Grade 10, 11 & 12)

- The foundation is the most important part of any building.
- Foundations must be in solid ground.
- Foundations are influenced by the soil structure (sandy, clay & rock).

WHY FOUNDATIONS?

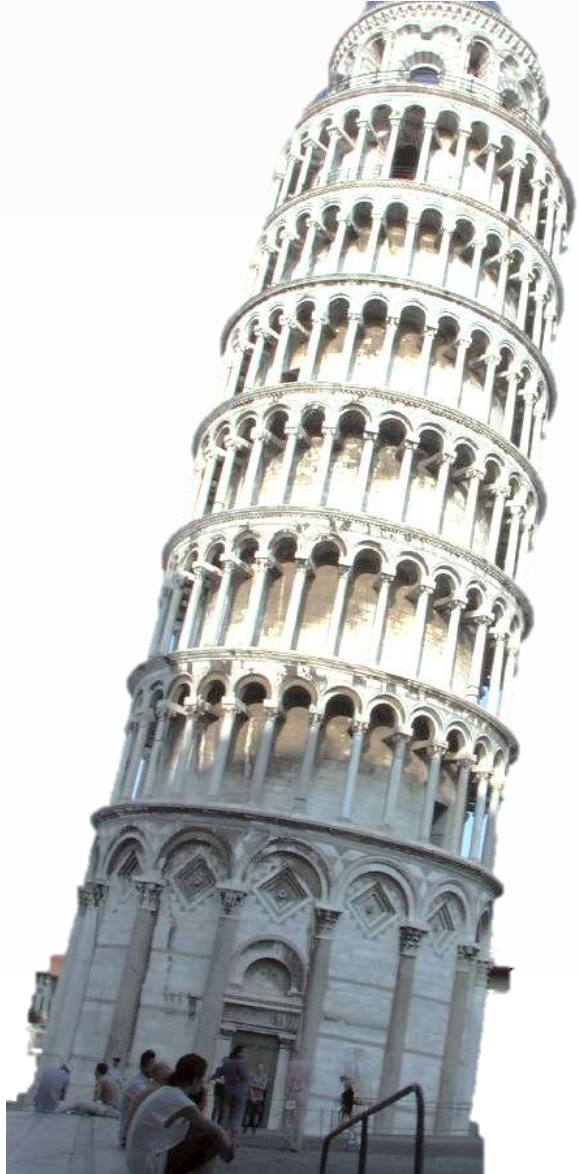

- Walls are very heavy
- Walls are standing on soft soil.
- Without foundations the weight of the building is not spread evenly

FOUNDATIONS

Work from Natural Ground Level (NGL)

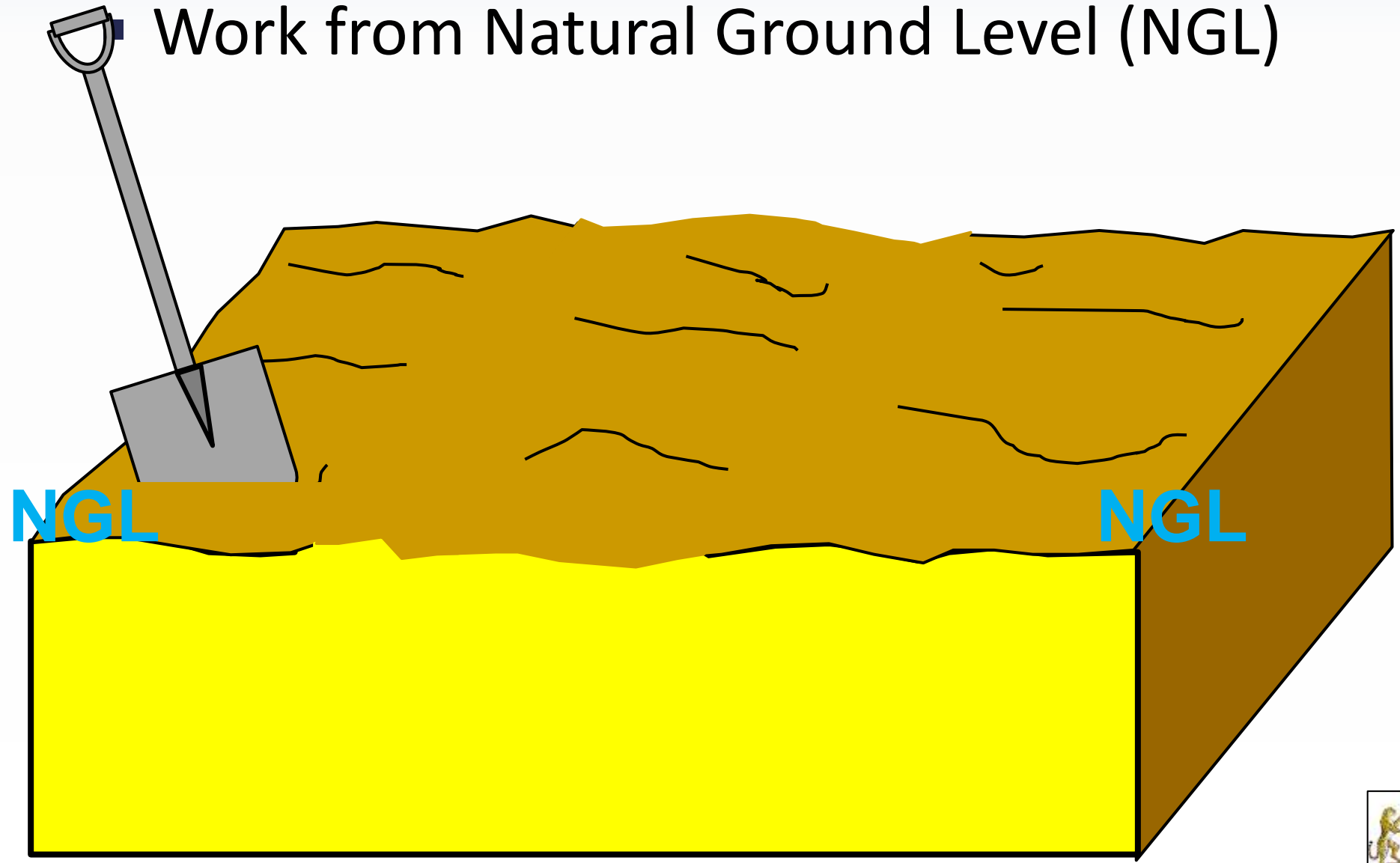

NATURAL GROUND LEVEL (NGL)

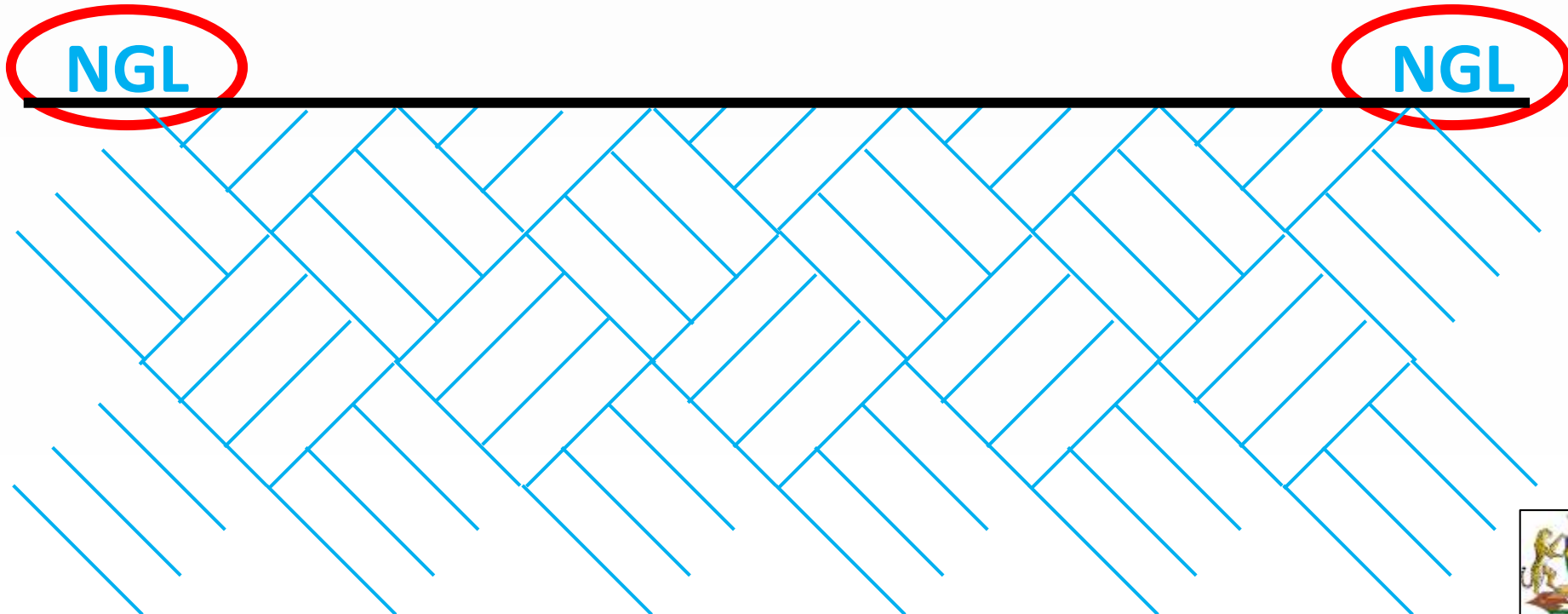

FOUNDATIONS

- Plot and measure the foundation area exactly according to the specifications



FOUNDATIONS

- Dig out all foundation trenches

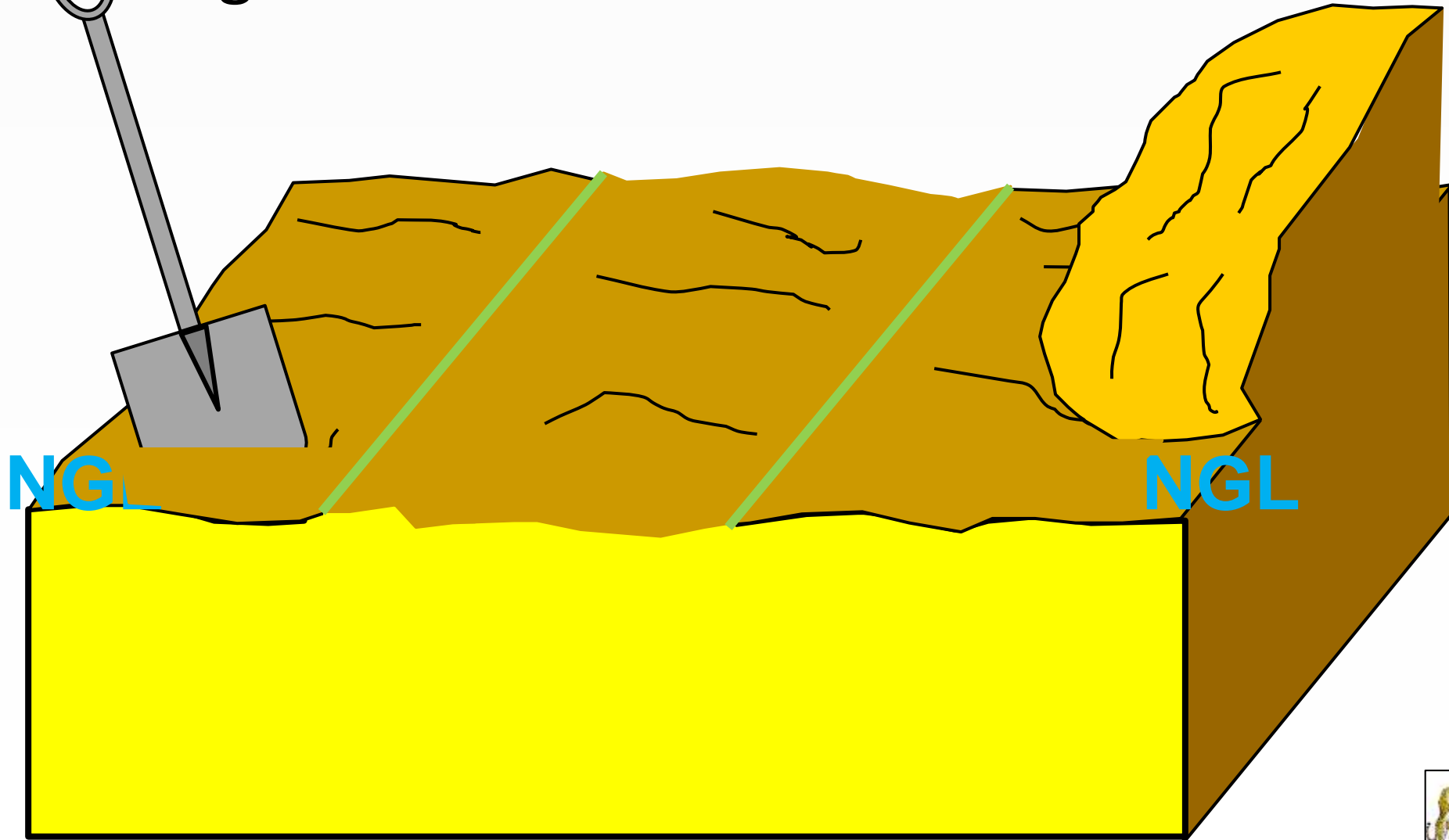

FOUNDATIONS



FOUNDATION TRENCHES

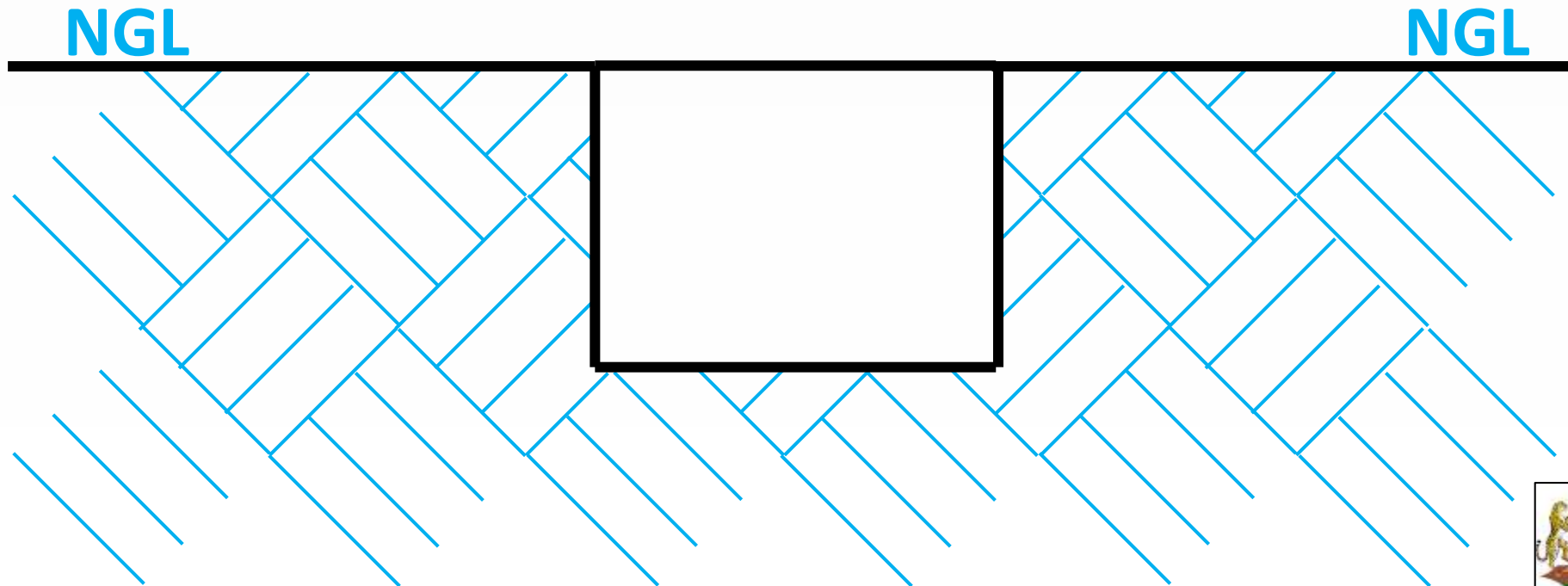

FOUNDATIONS

- Cast the concrete foundations

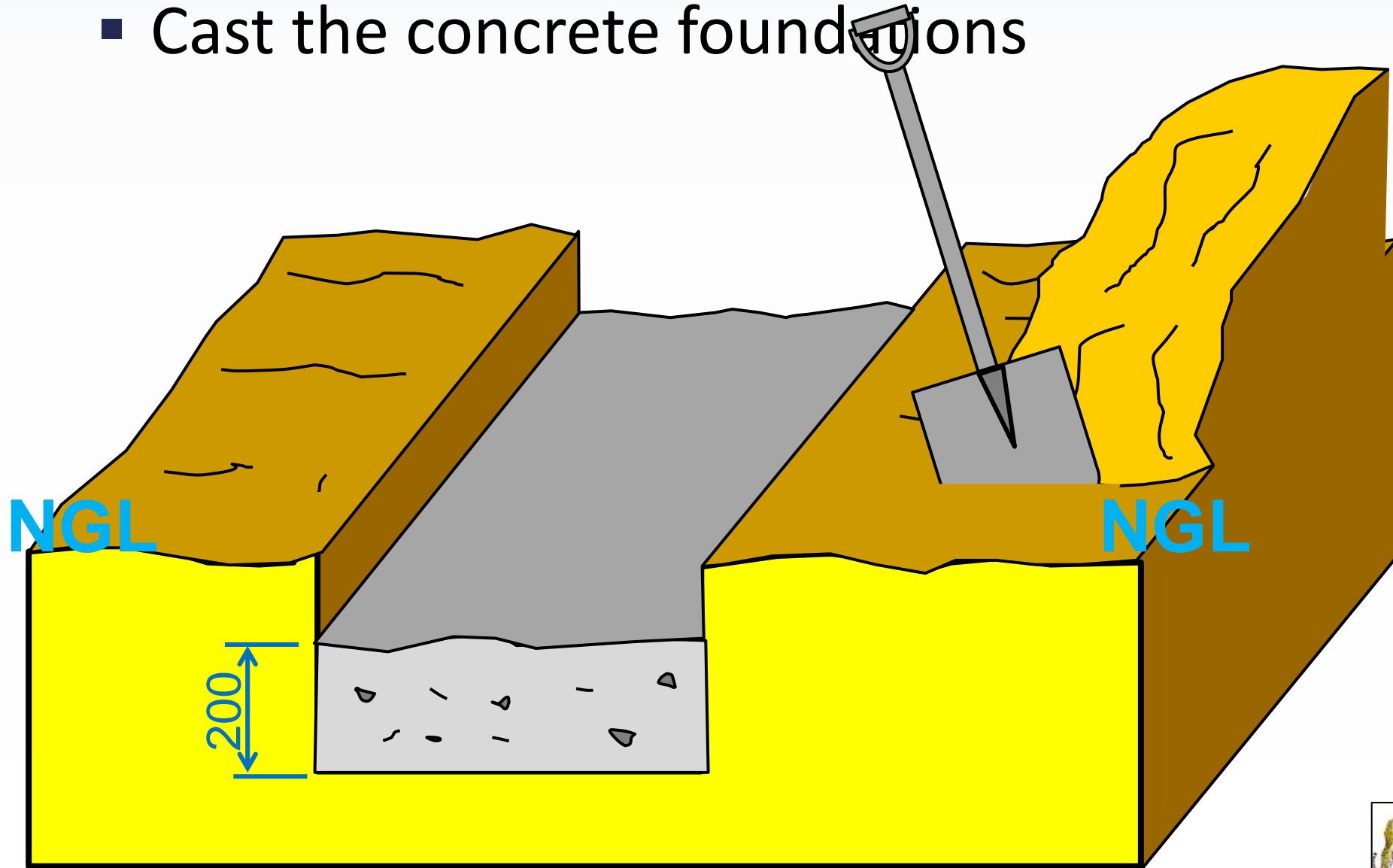

FOUNDATIONS



FOUNDATION TRENCHES FILLED WITH CONCRETE

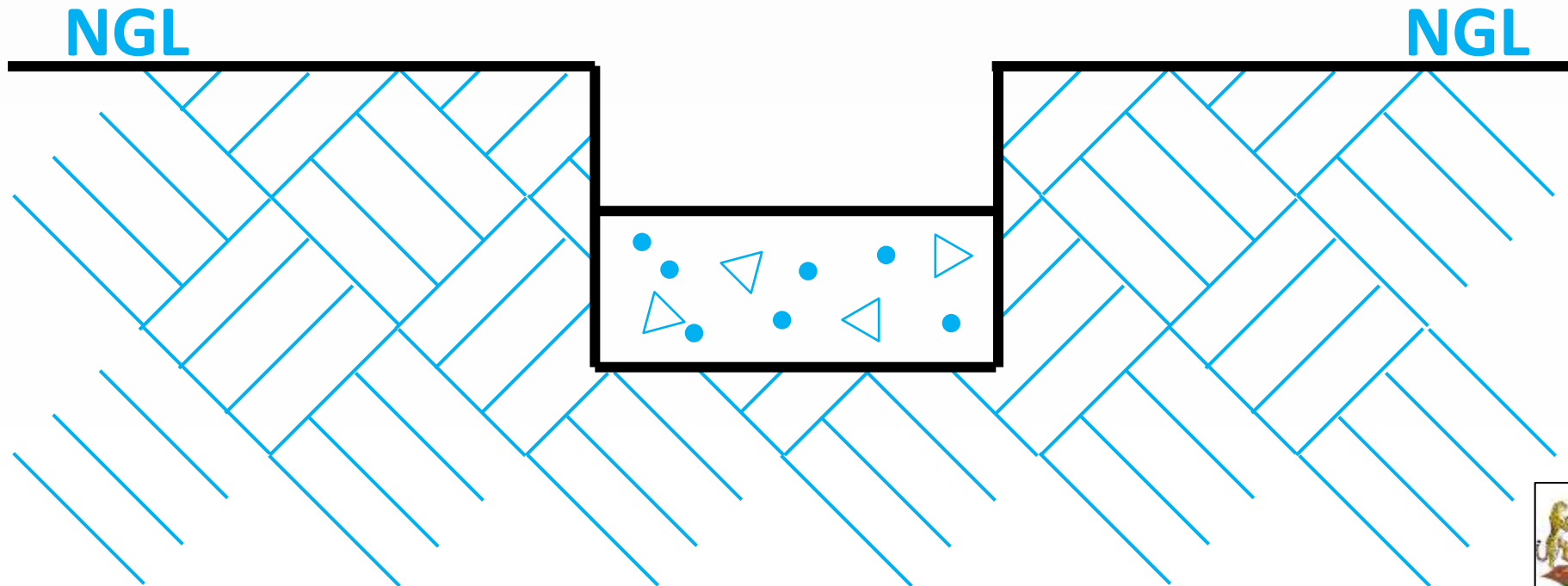

FOUNDATION DIMENSIONS

- **The foundation depth** (normally not less than 150 deep)

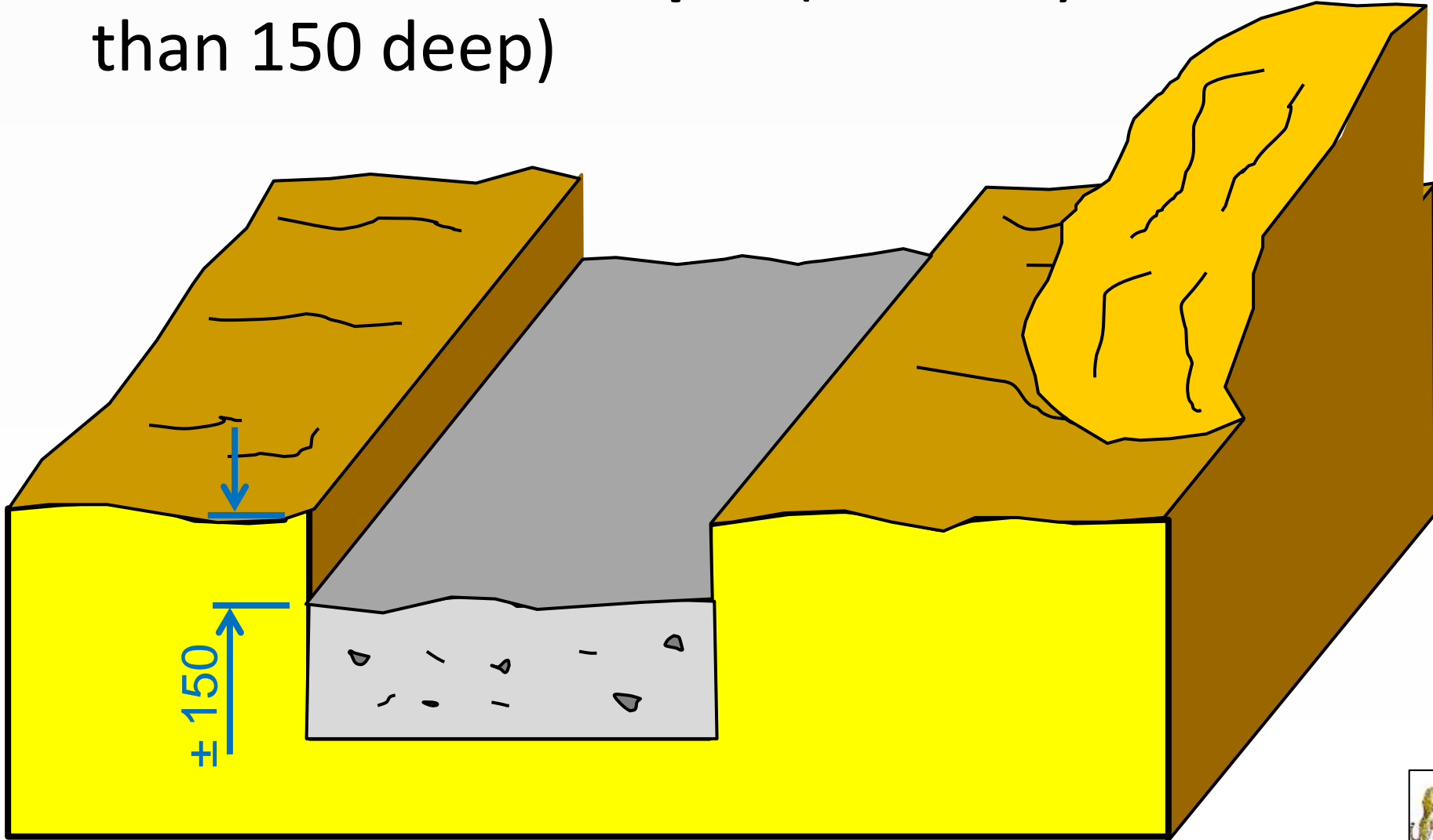

FOUNDATION DEPTH

- **The foundation depth** (normally not less than 150 deep)

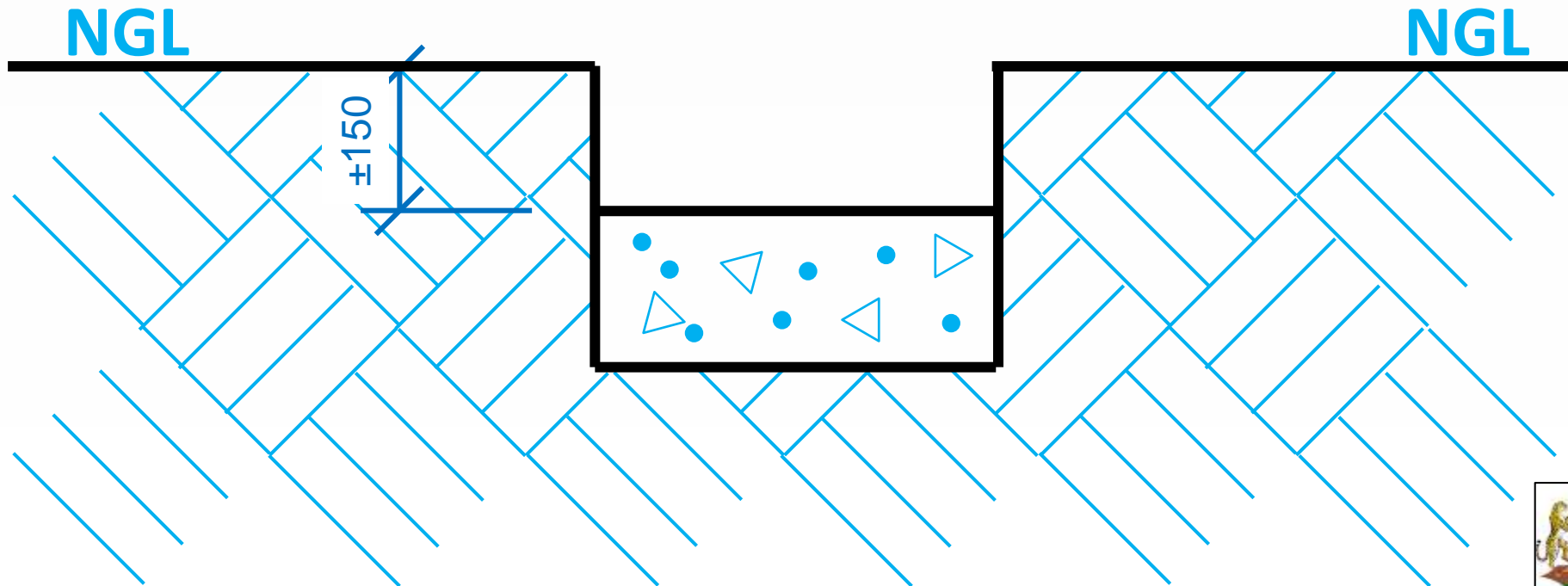

BRICK SIZE

DRAWING SIZE

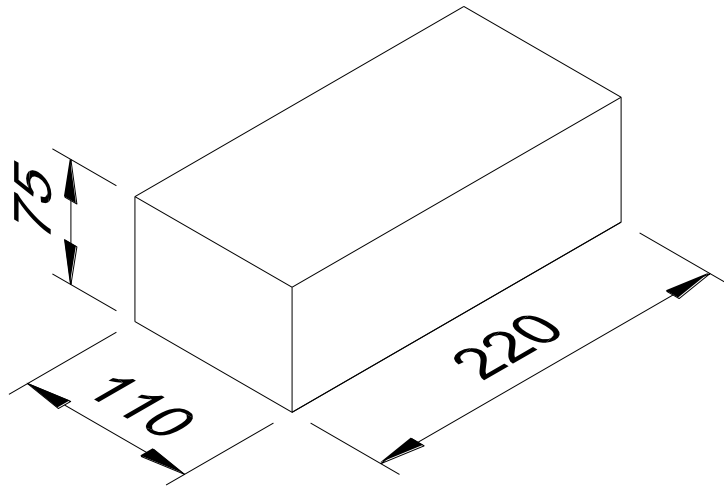

TRUE SIZE

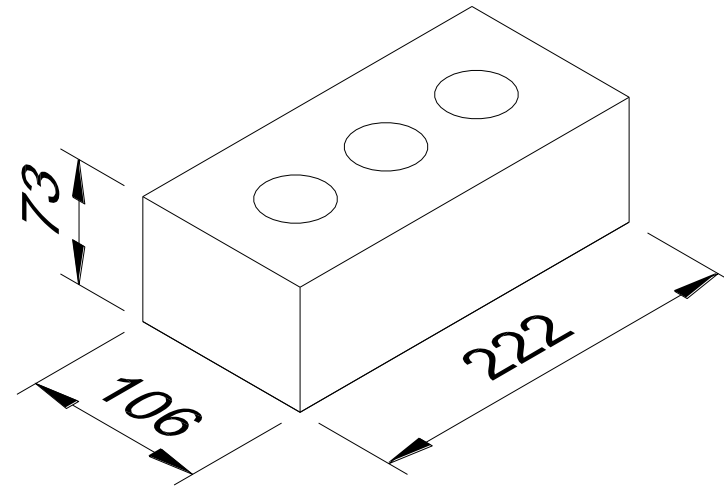

STANDARD SIZES FOR STOCK AND CLAY BRICK

BLOCK SIZES

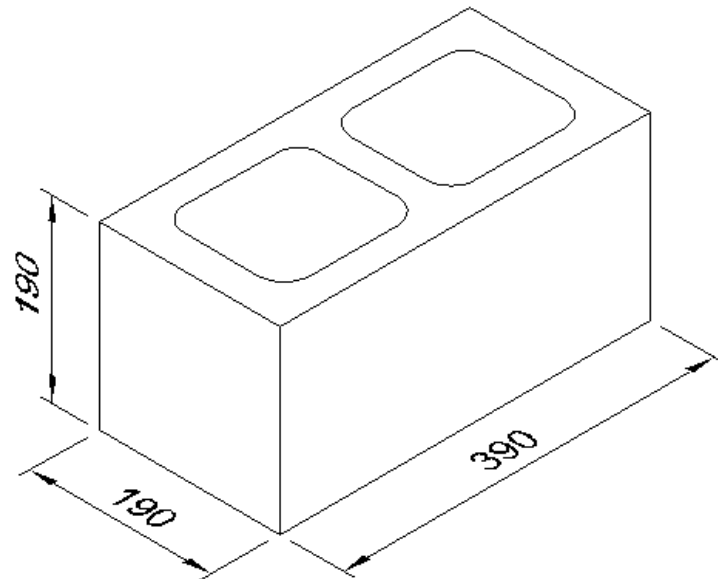
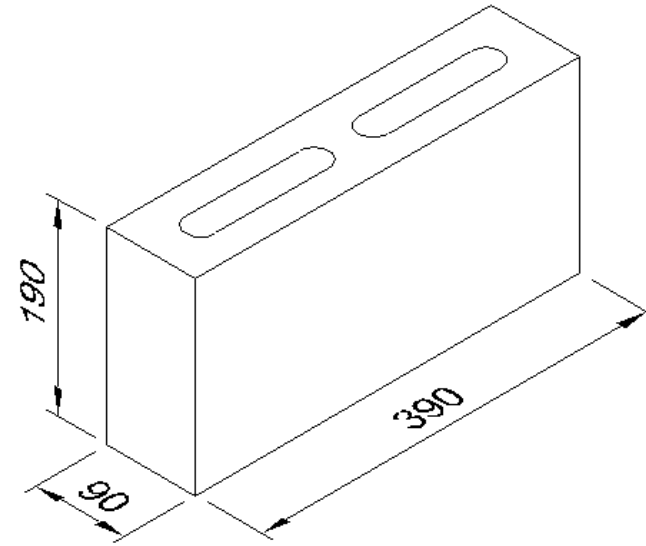
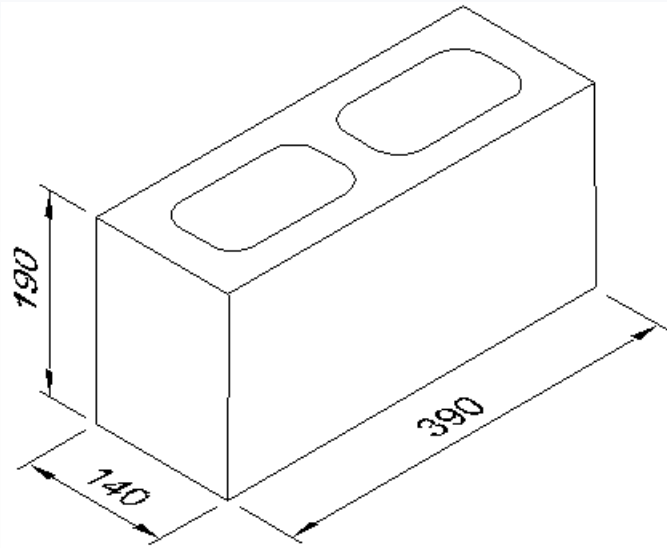

FOUNDATION DIMENSIONS

- Non load bearing walls (200 x 400)

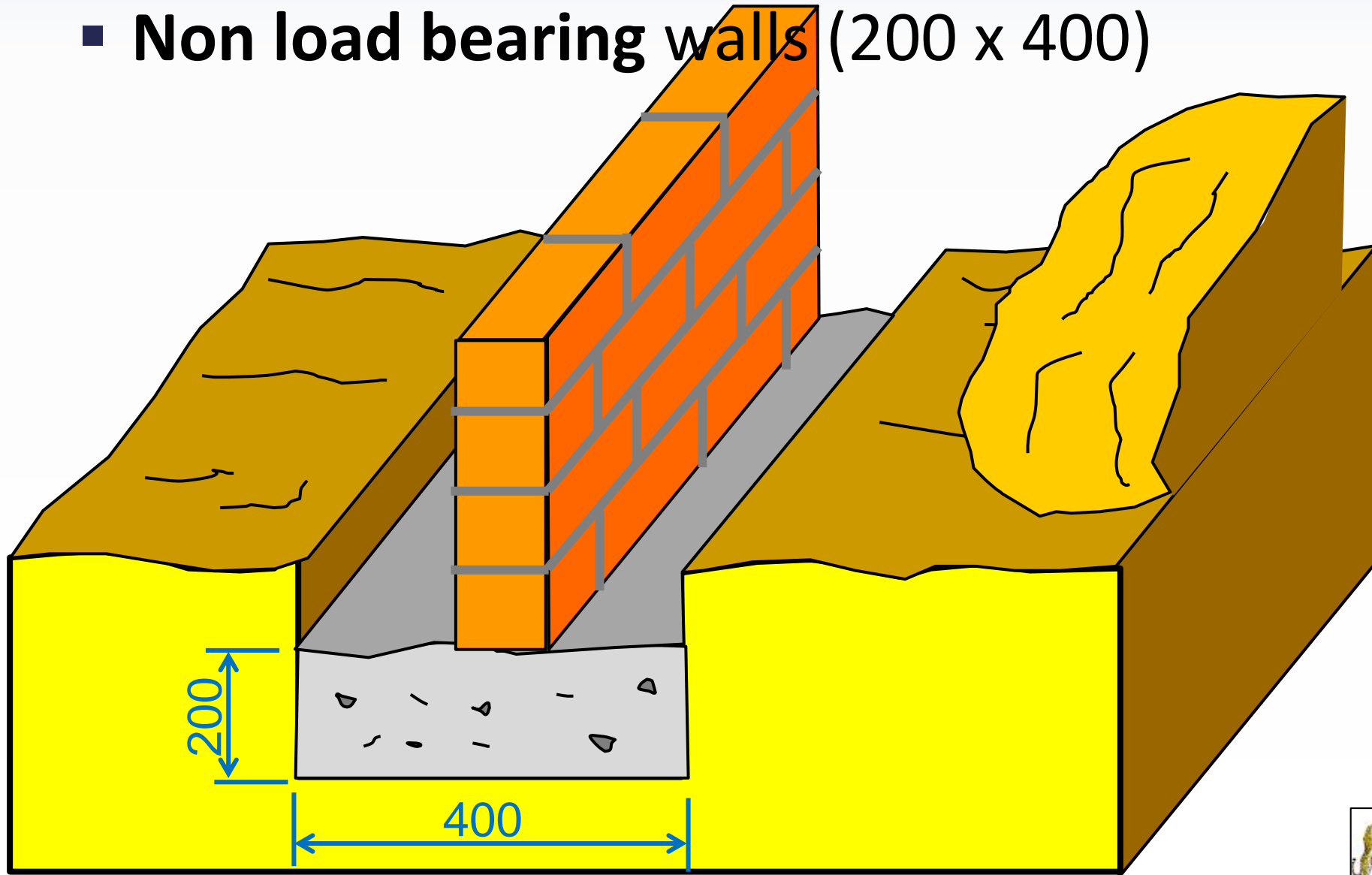

FOUNDATION DIMENSIONS

- Non load bearing walls (200 x 400)

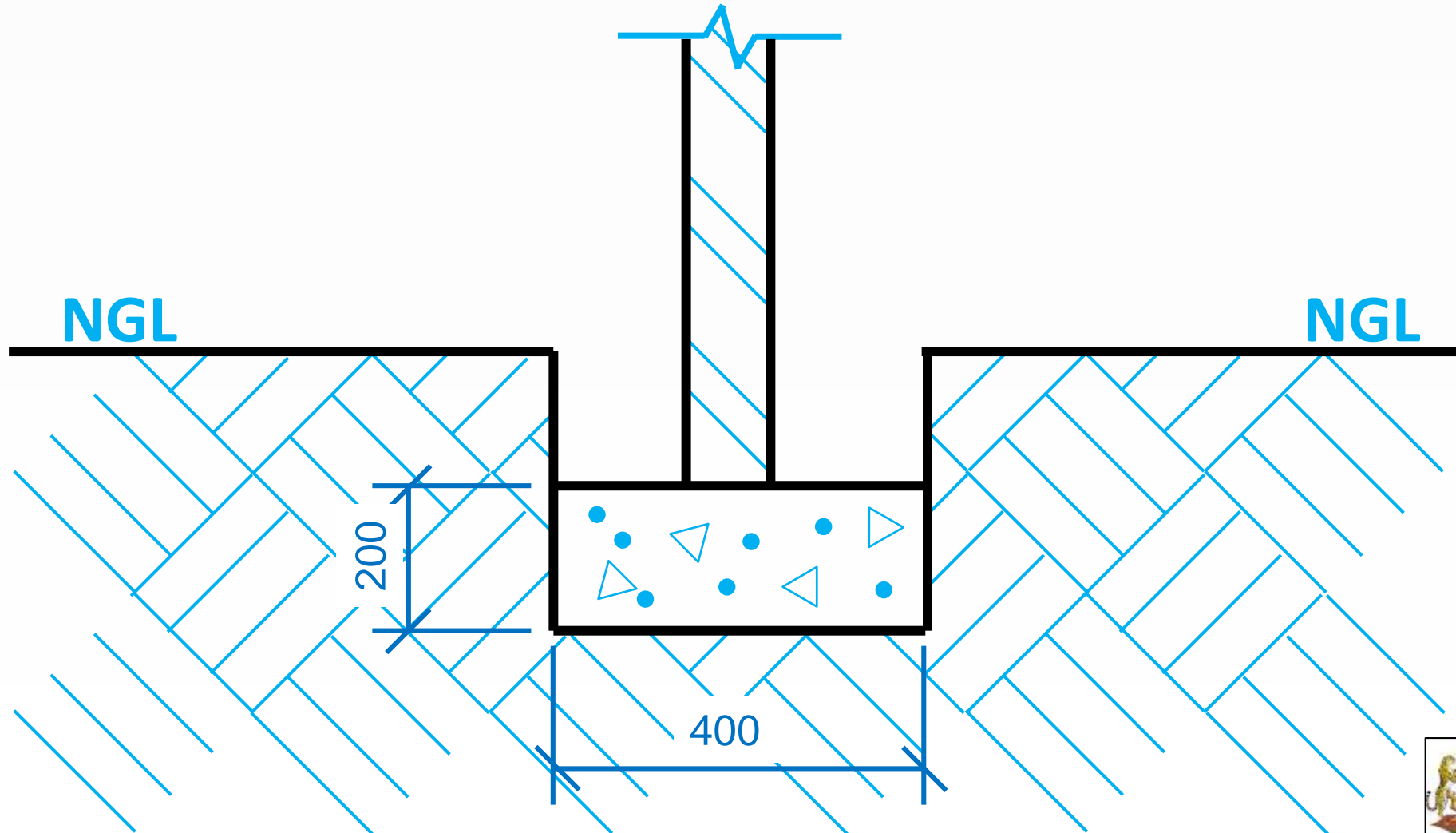

FOUNDATION DIMENSIONS

- Non load bearing wall (200 x 400)

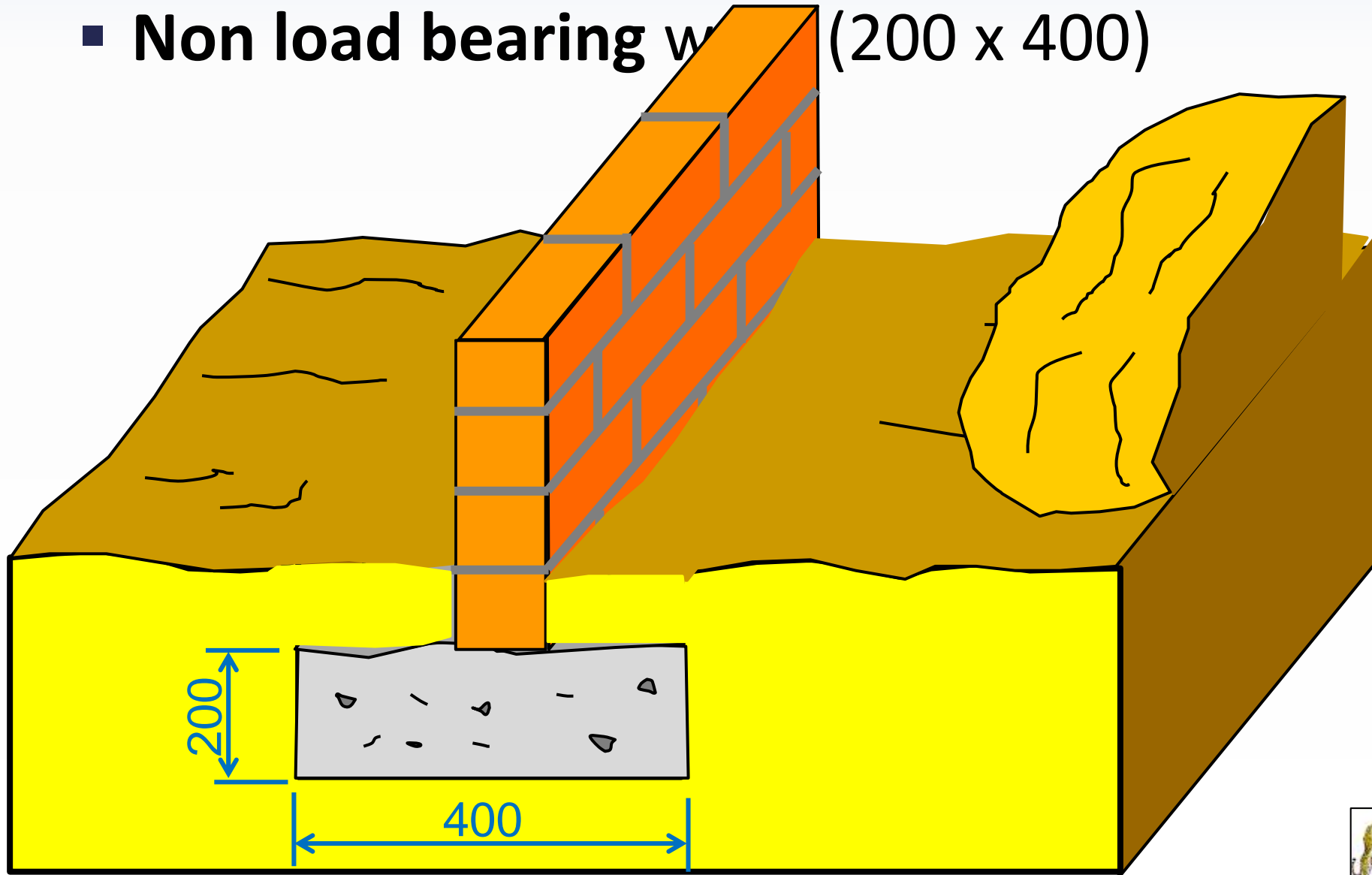

FOUNDATION FILLING & COMPACTING

- Non load bearing walls (200 x 400)

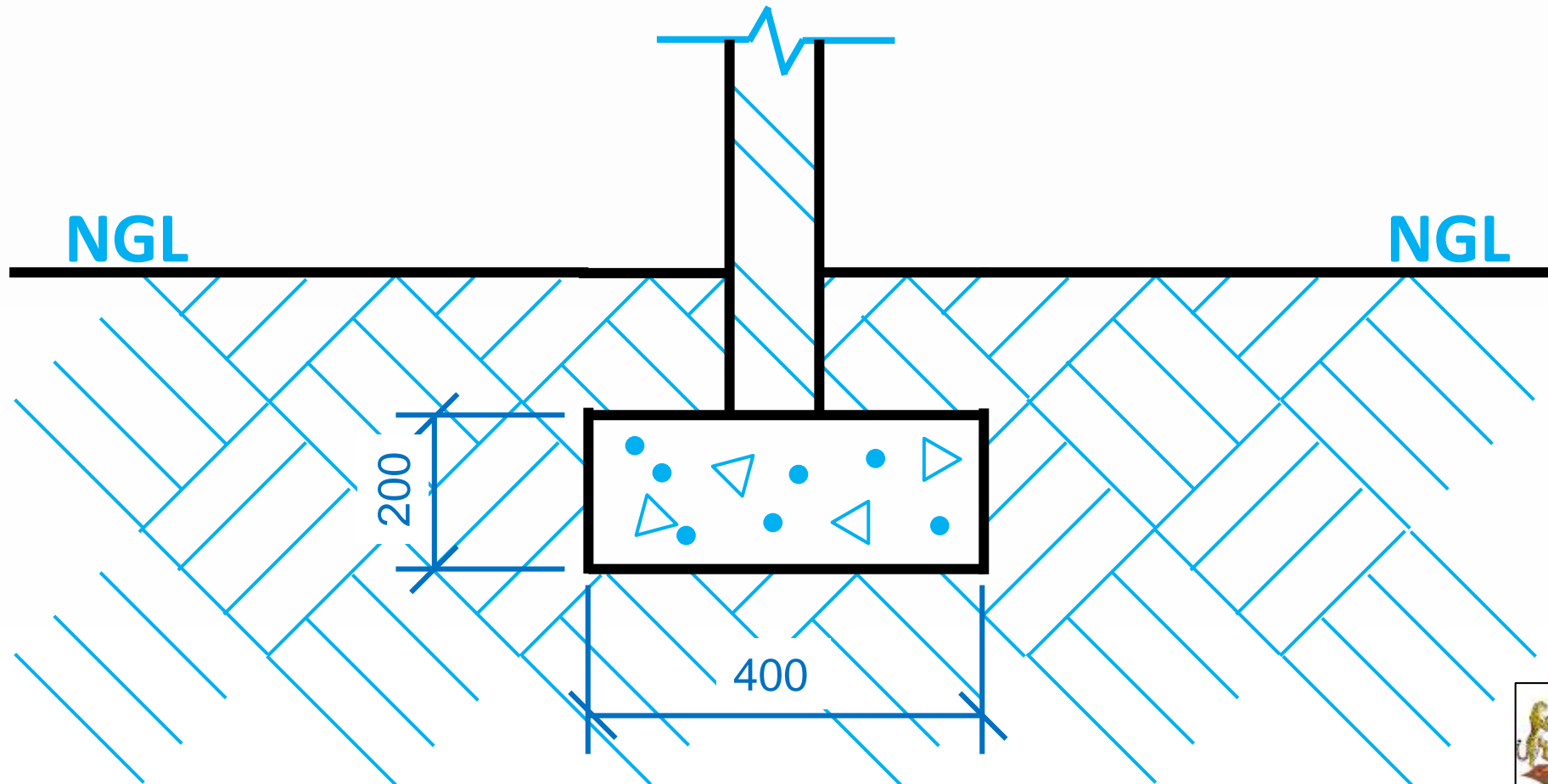

A SECTIONED VIEW (grade 12 level)

SNIT OP AA

SKAAL 1:100

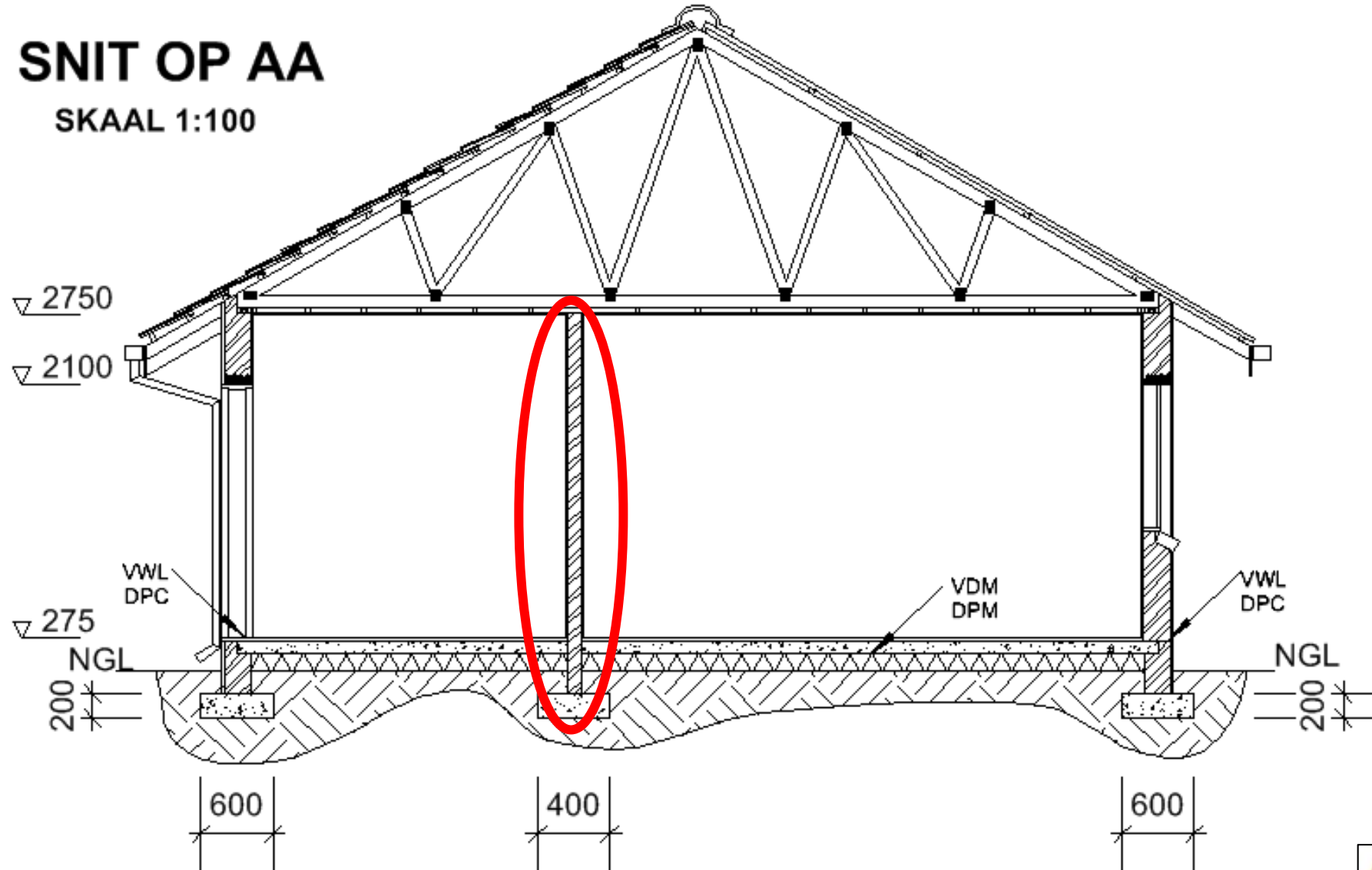

FOUNDATION DIMENSIONS

- Load bearing walls (200 x 600)

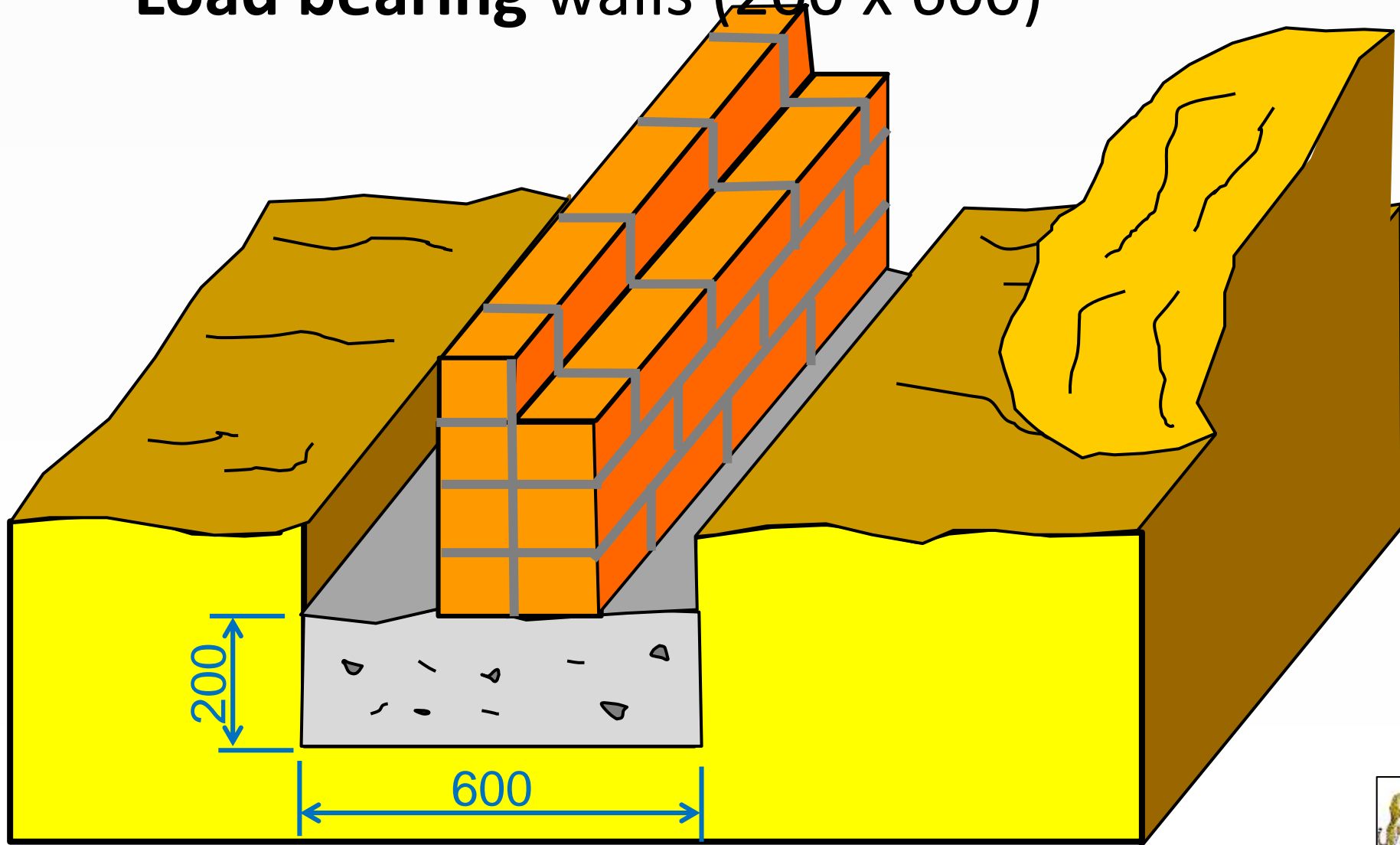

FOUNDATION DIMENSIONS

- Load bearing walls (200 x 600)

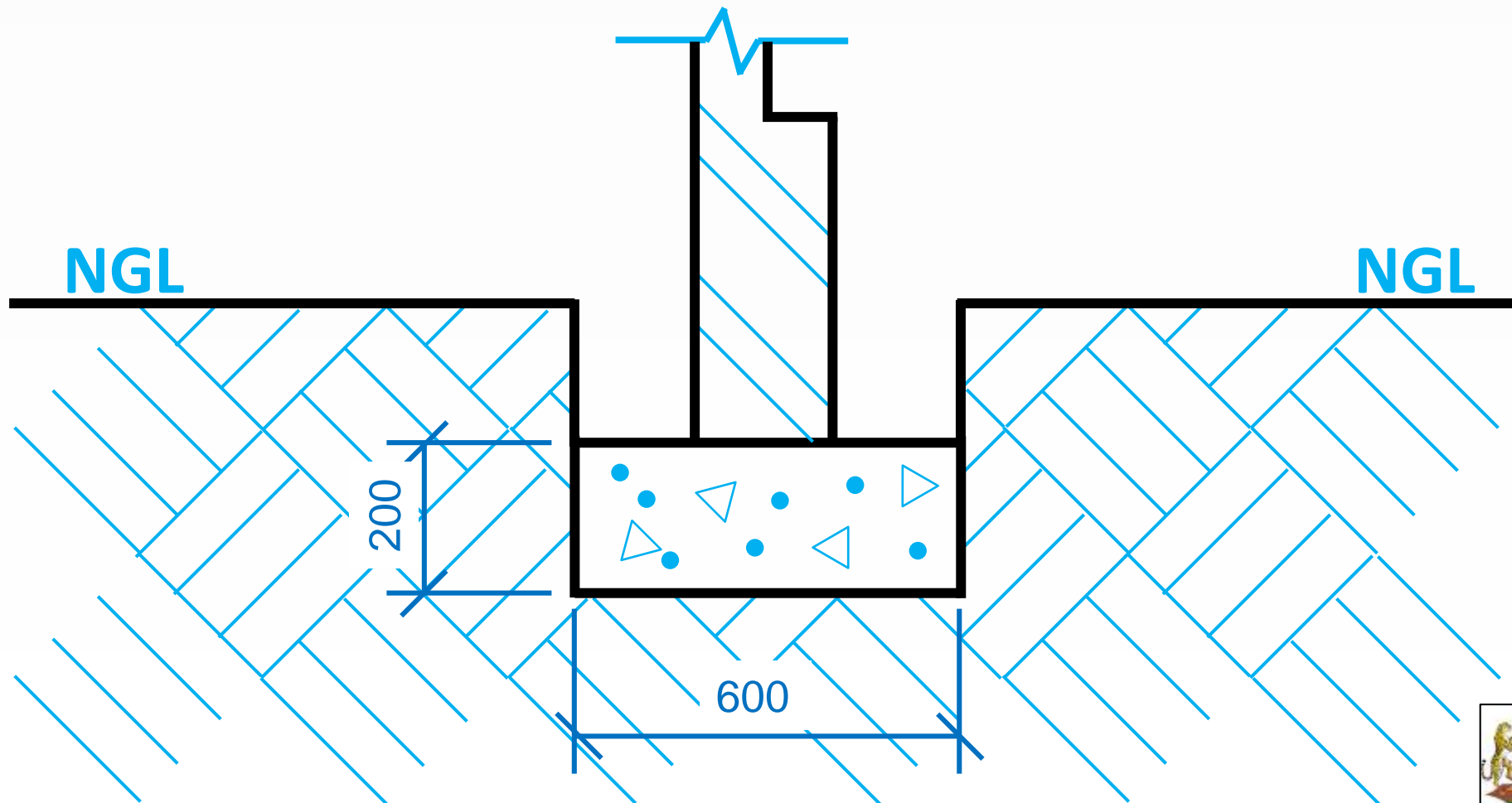

FILLING AND COMPACTING

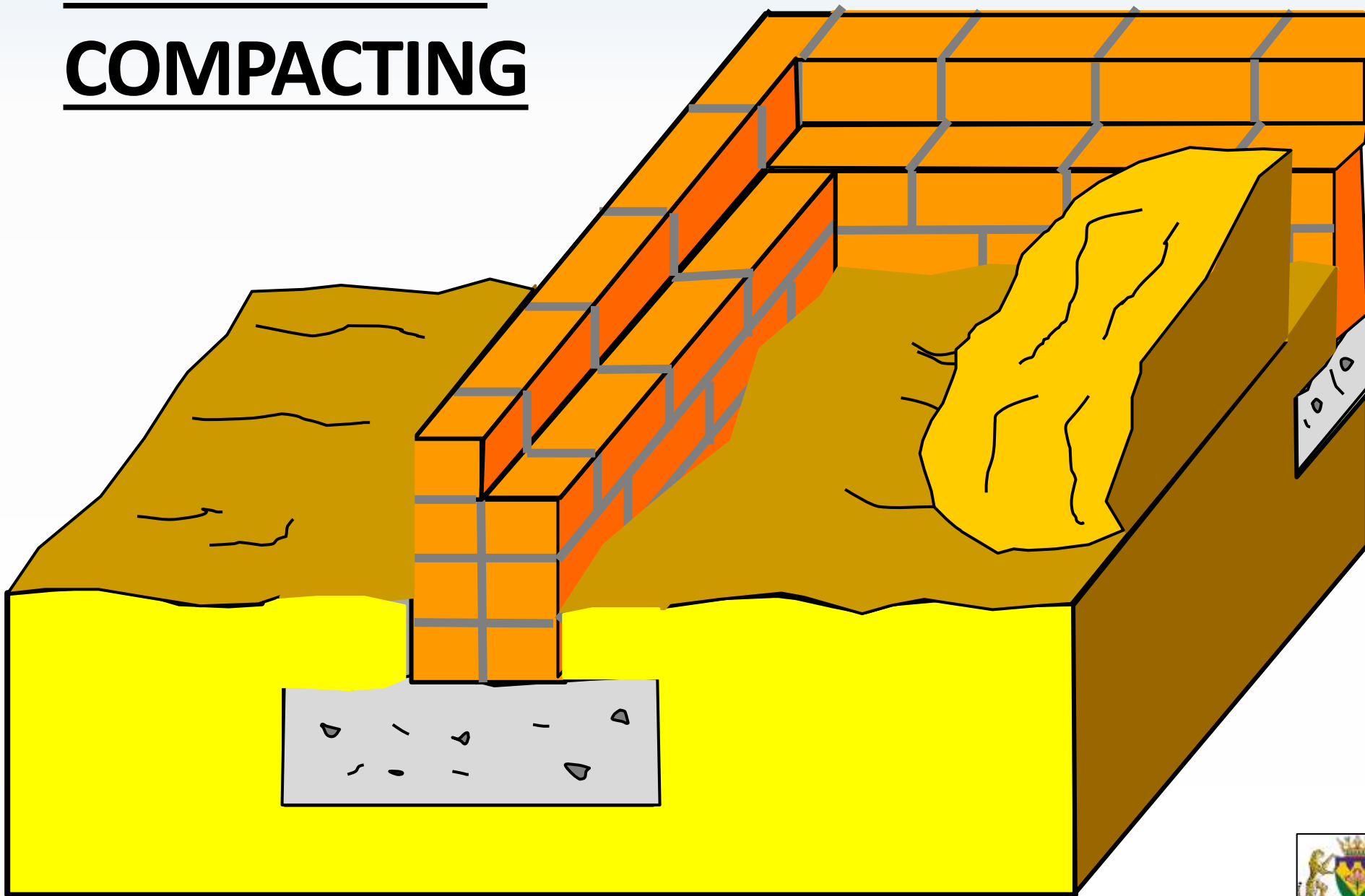

FOUNDATION FILLING & COMPACTING

- Load bearing walls (200 x 600)

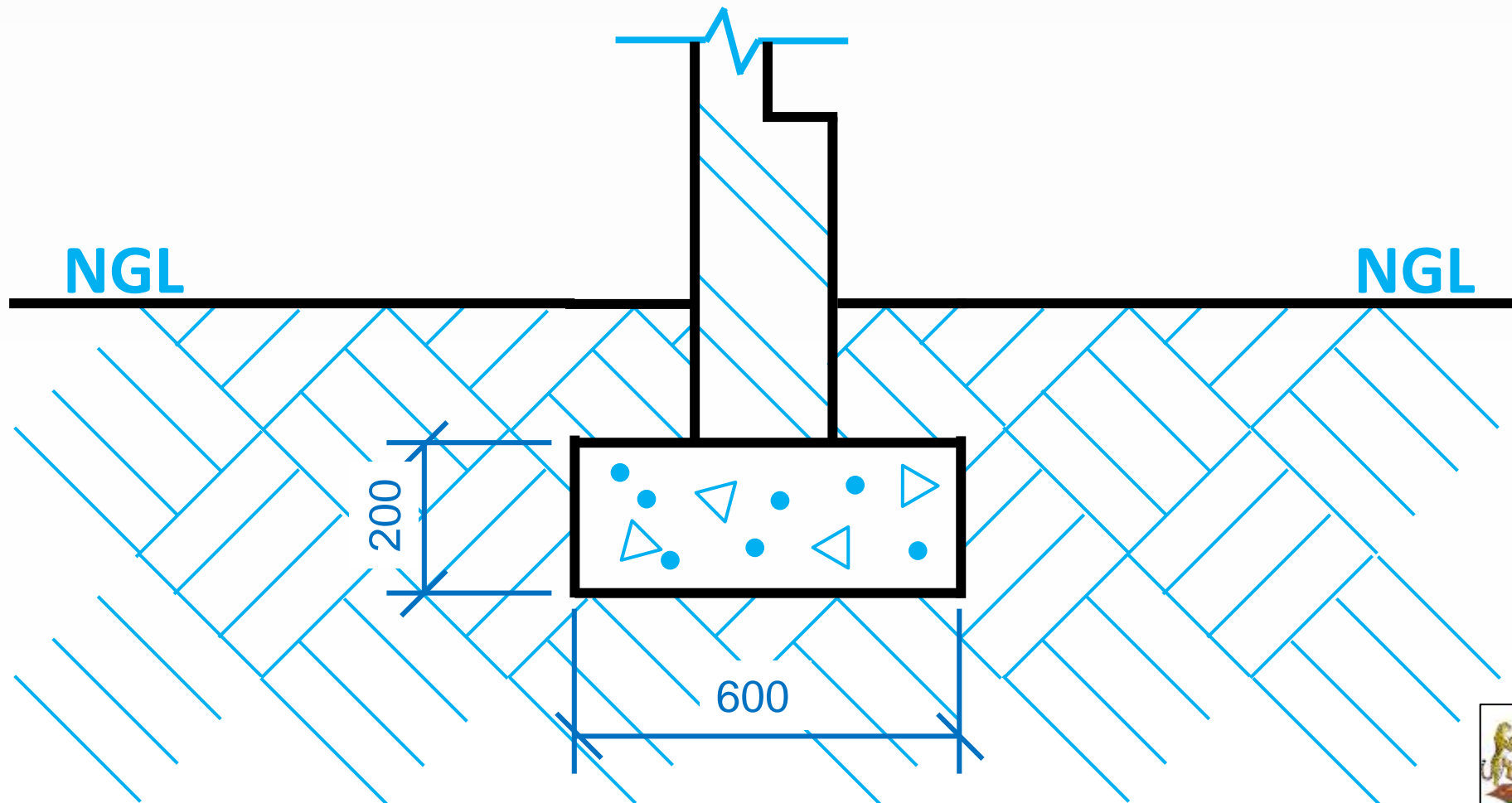

A SECTIONED VIEW (grade 12 level)

SNIT OP AA

SKAAL 1:100

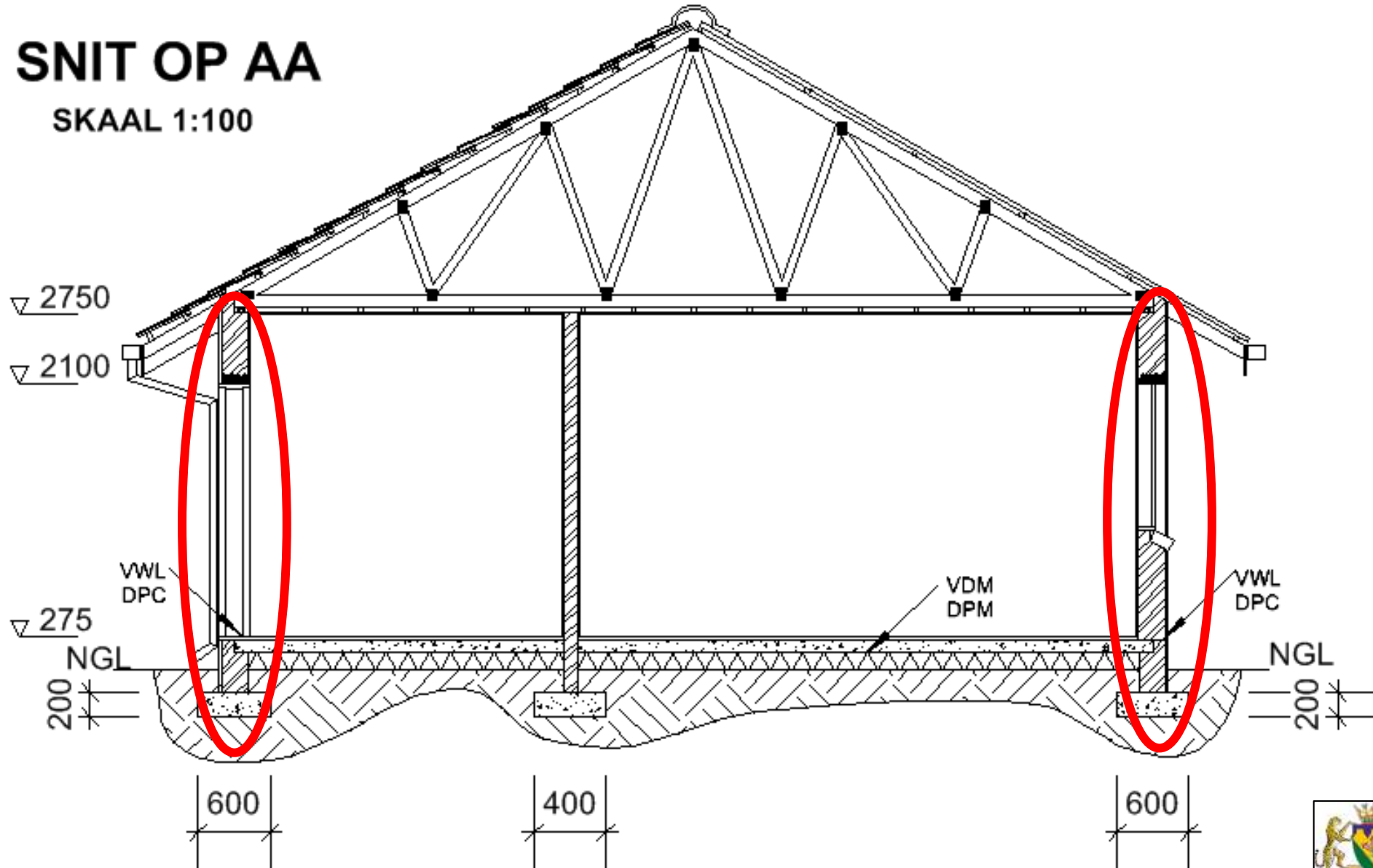

FOUNDATION DIMENSIONS

- Cavity walls (230 x 730)

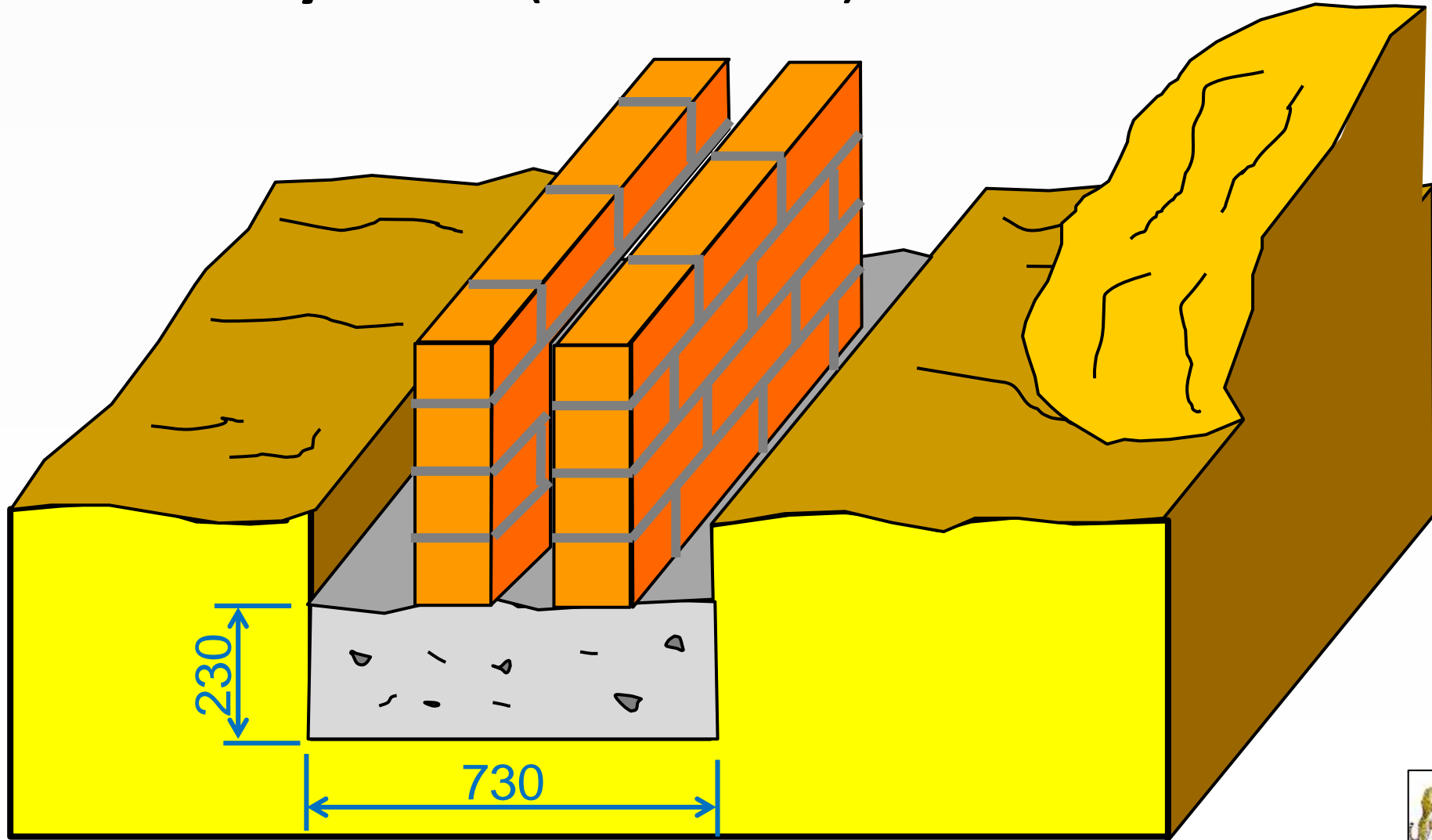

FOUNDATION FILLING & COMPACTING

- Cavity walls (230 x 730)

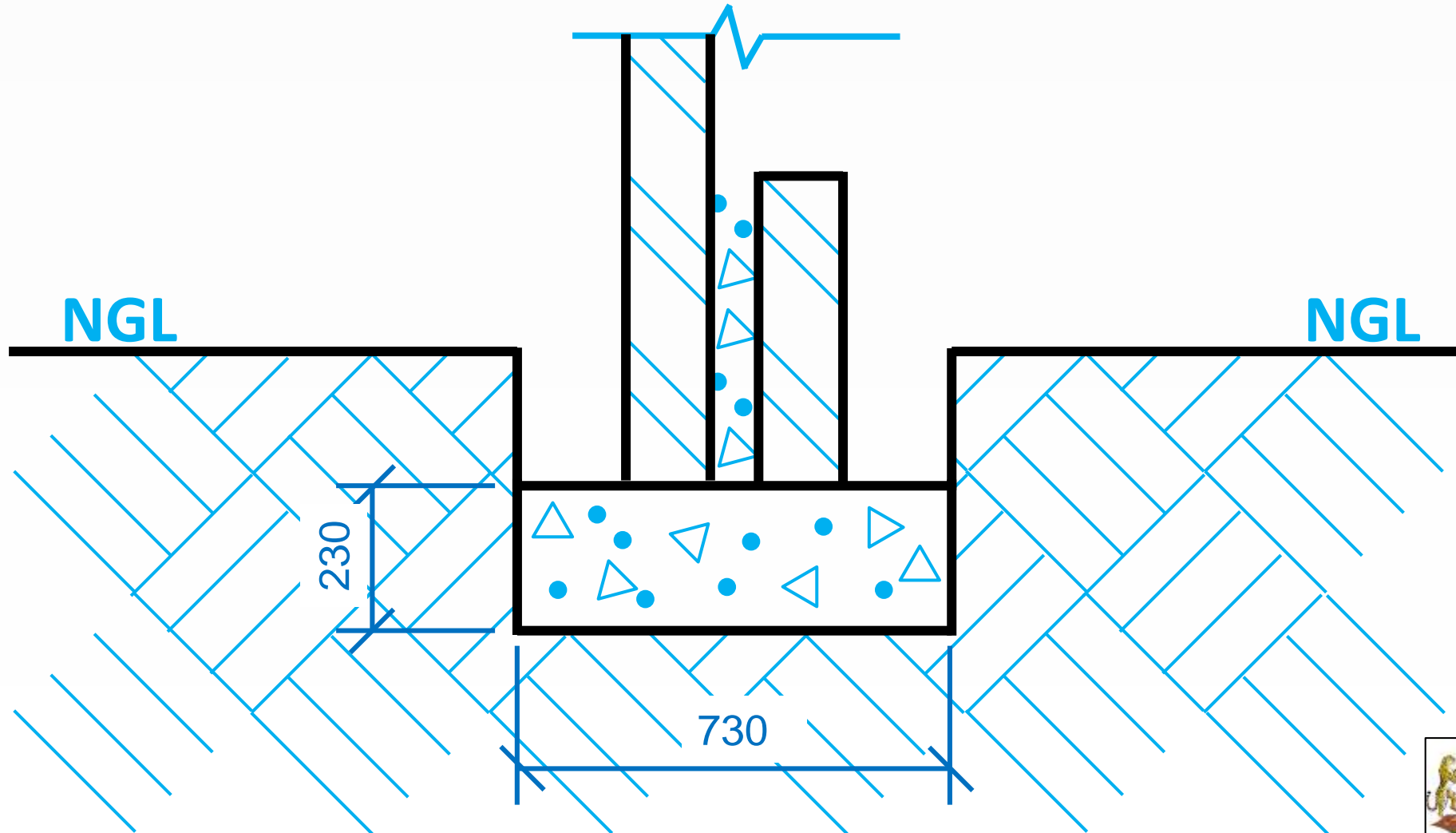

FOUNDATION FILLING & COMPACTING

- Cavity walls (230 x 730)

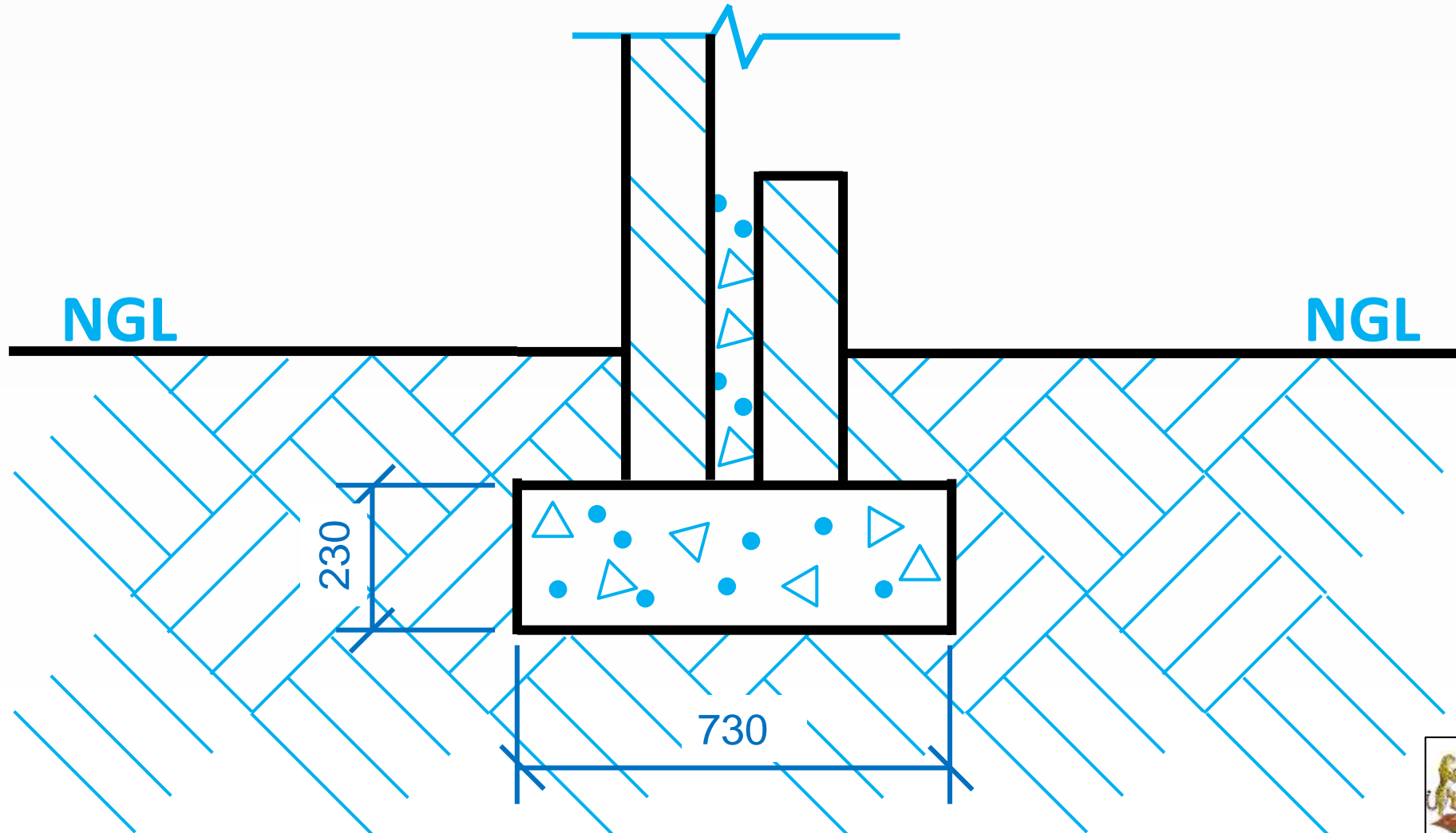

FOUNDATION DIMENSIONS

- The cavity is never less than 50mm apart
- Must be free of any cement in between.



FILLING & COMPACTING



education

Department of
Education
FREE STATE PROVINCE

FILLING AND COMPACTING

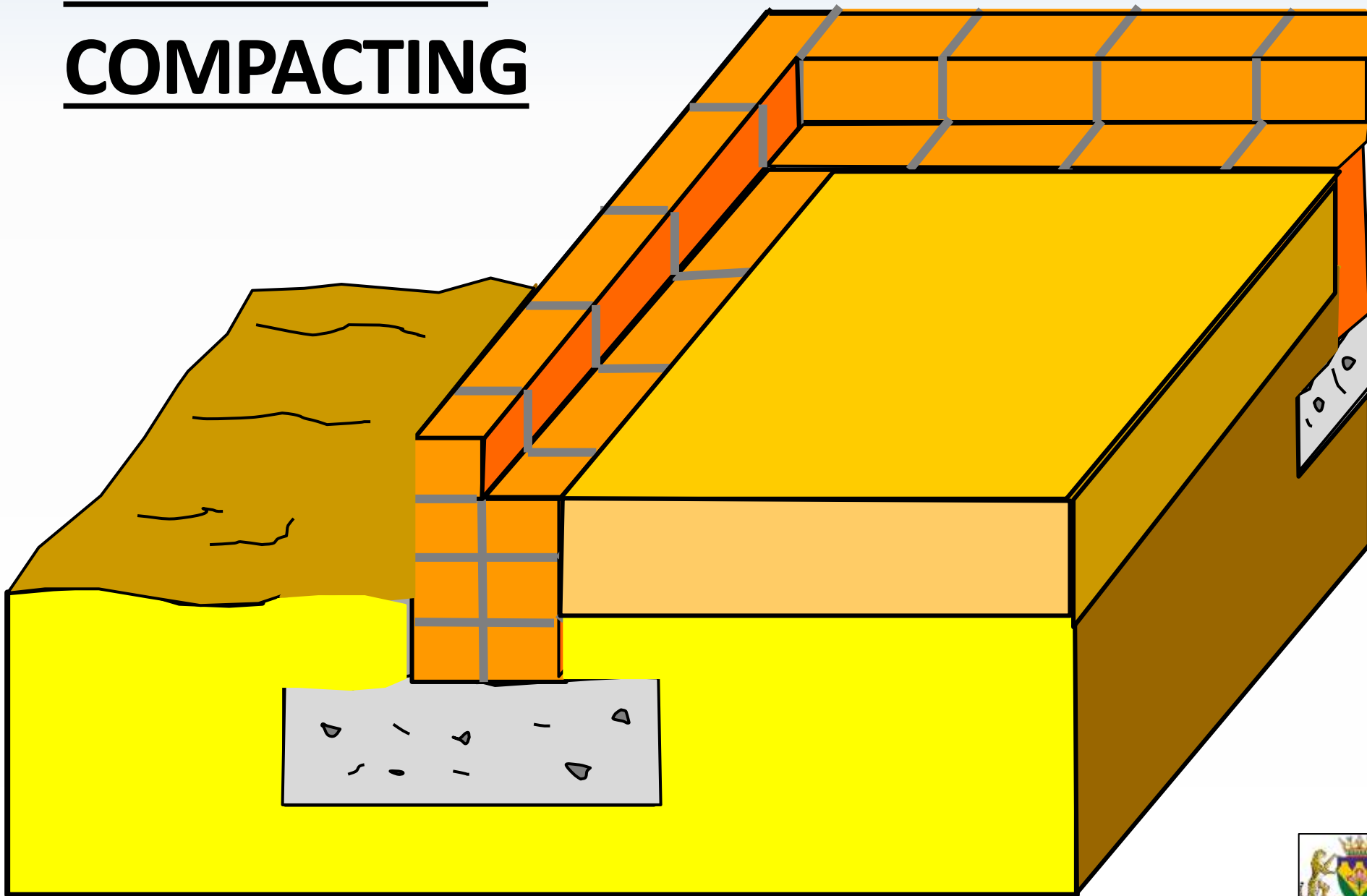

FILLING & COMPACTING



FILLING & COMPACTING

- Hard core filling

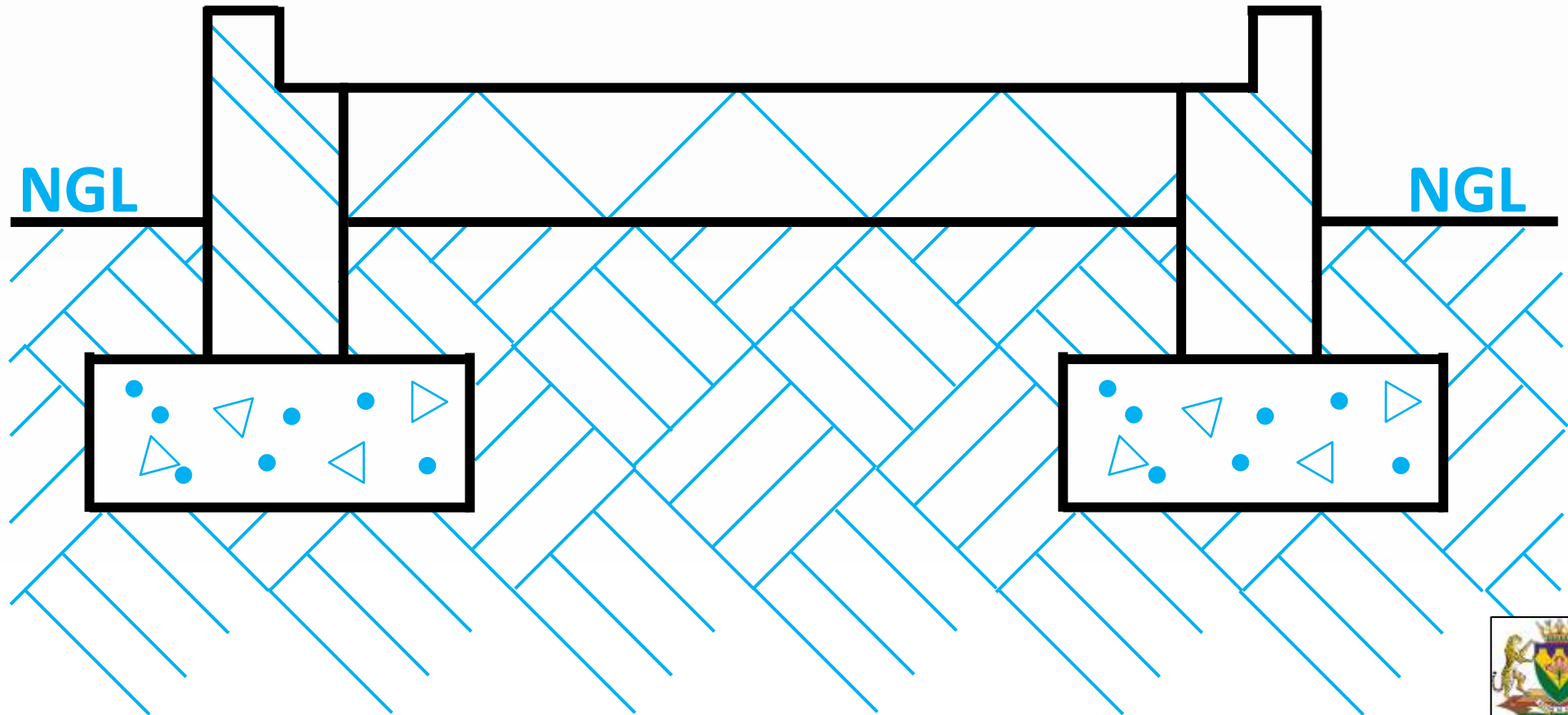

FILLING & COMPACTING

- **Hard core filling at load bearing & non-load bearing walls**

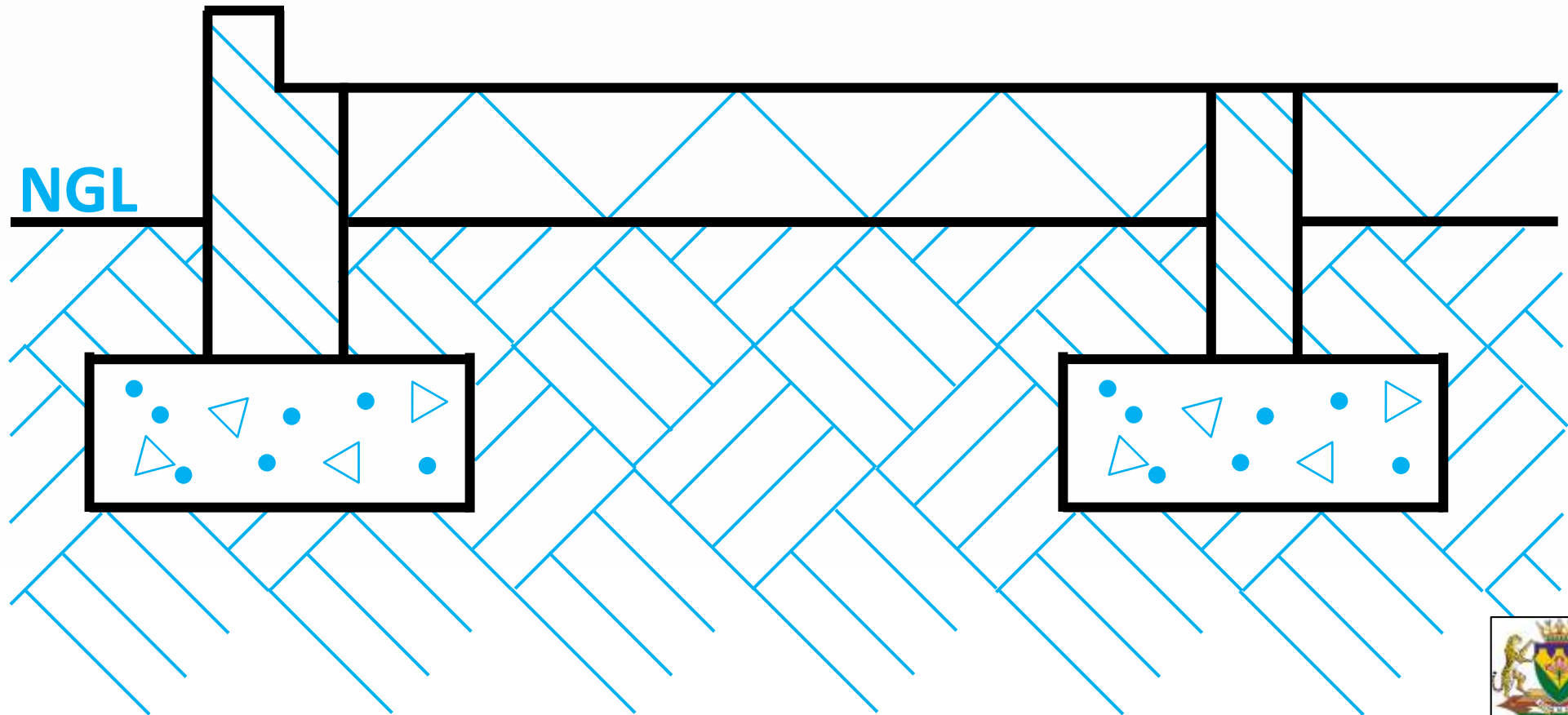

FILLING & COMPACTING

- Compacting not thicker than 150 mm at a time should be allowed.
- Plant material and bricks must be removed when preparing the ground for compacting.

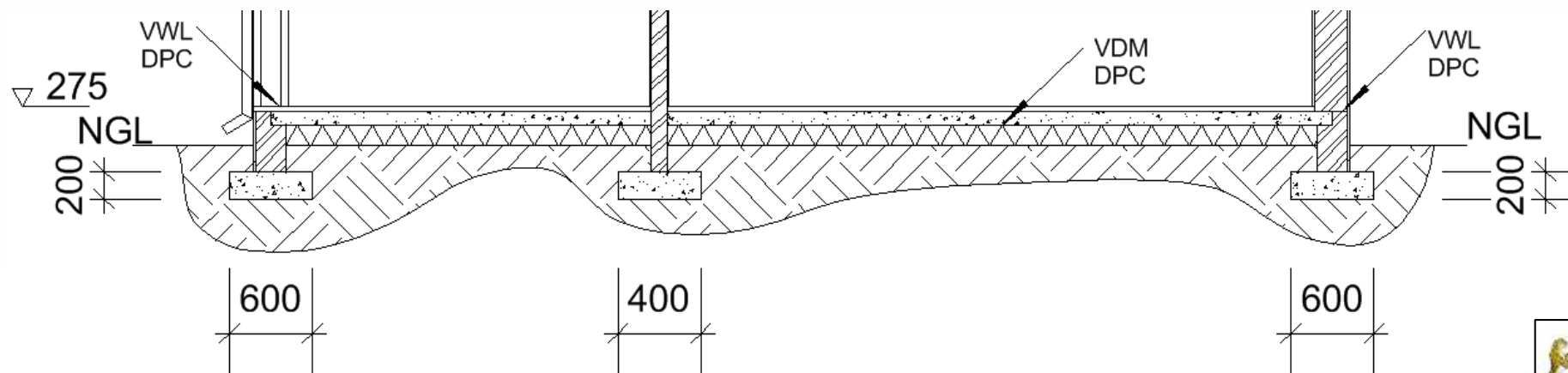

DPM (DAMP PROOF MEMBRANE)

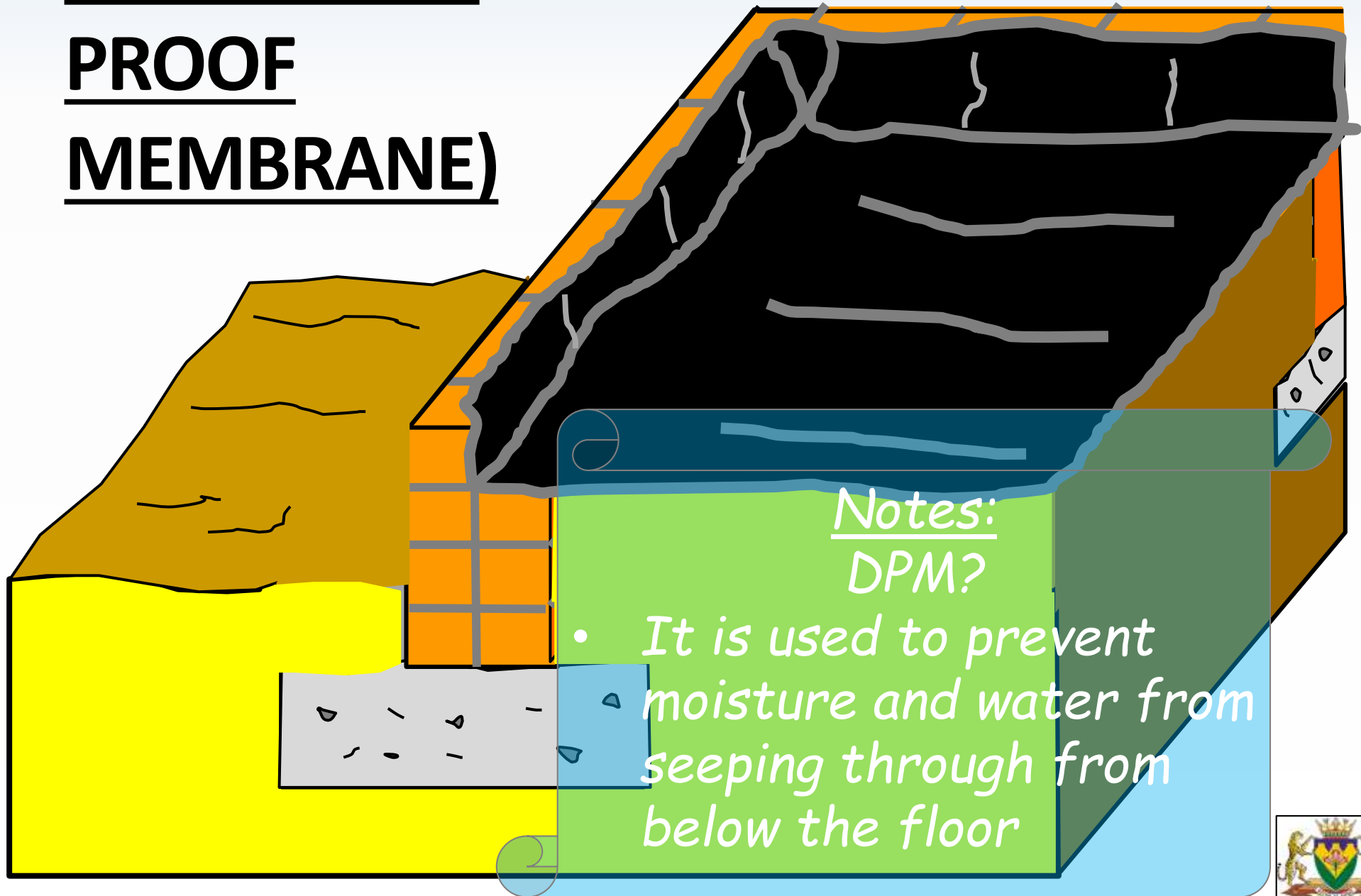

DAMP PROOF MEMBRANE (DPM)



FOUNDATION FILLING & COMPACTING

- DPM at load bearing walls

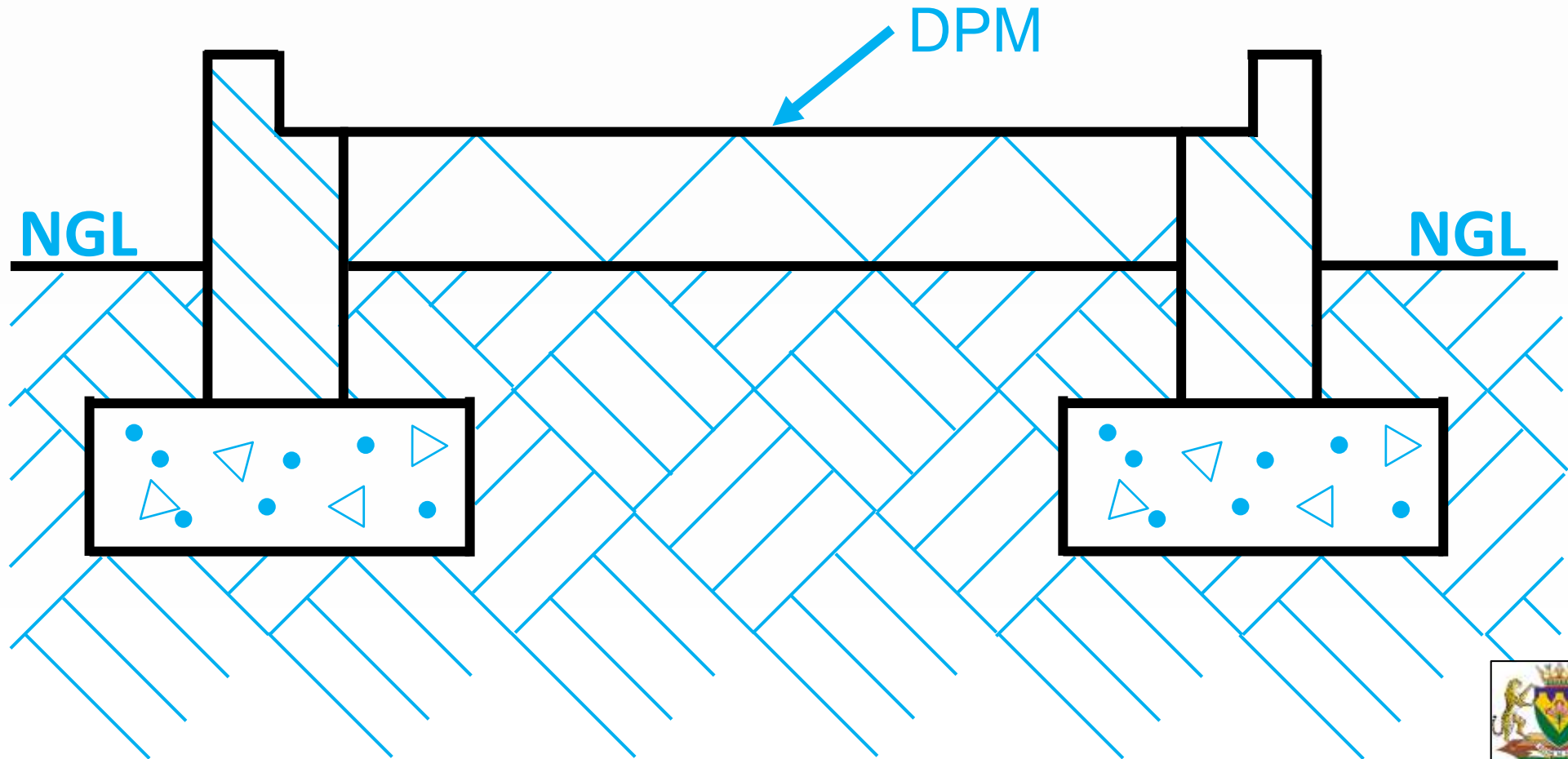

FOUNDATION FILLING & COMPACTING

- DPM at load bearing & non-load bearing walls

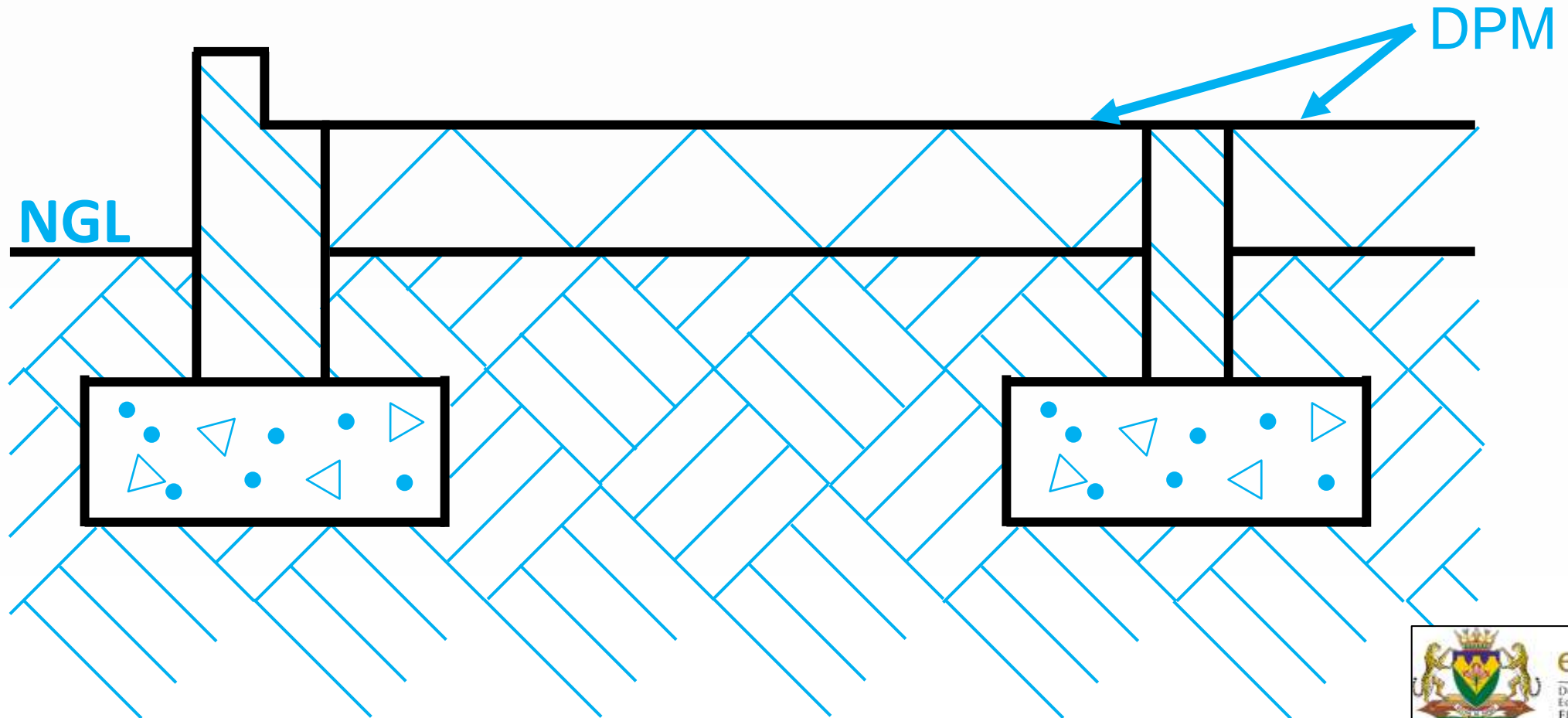

CAST THE CONCRETE SLAB

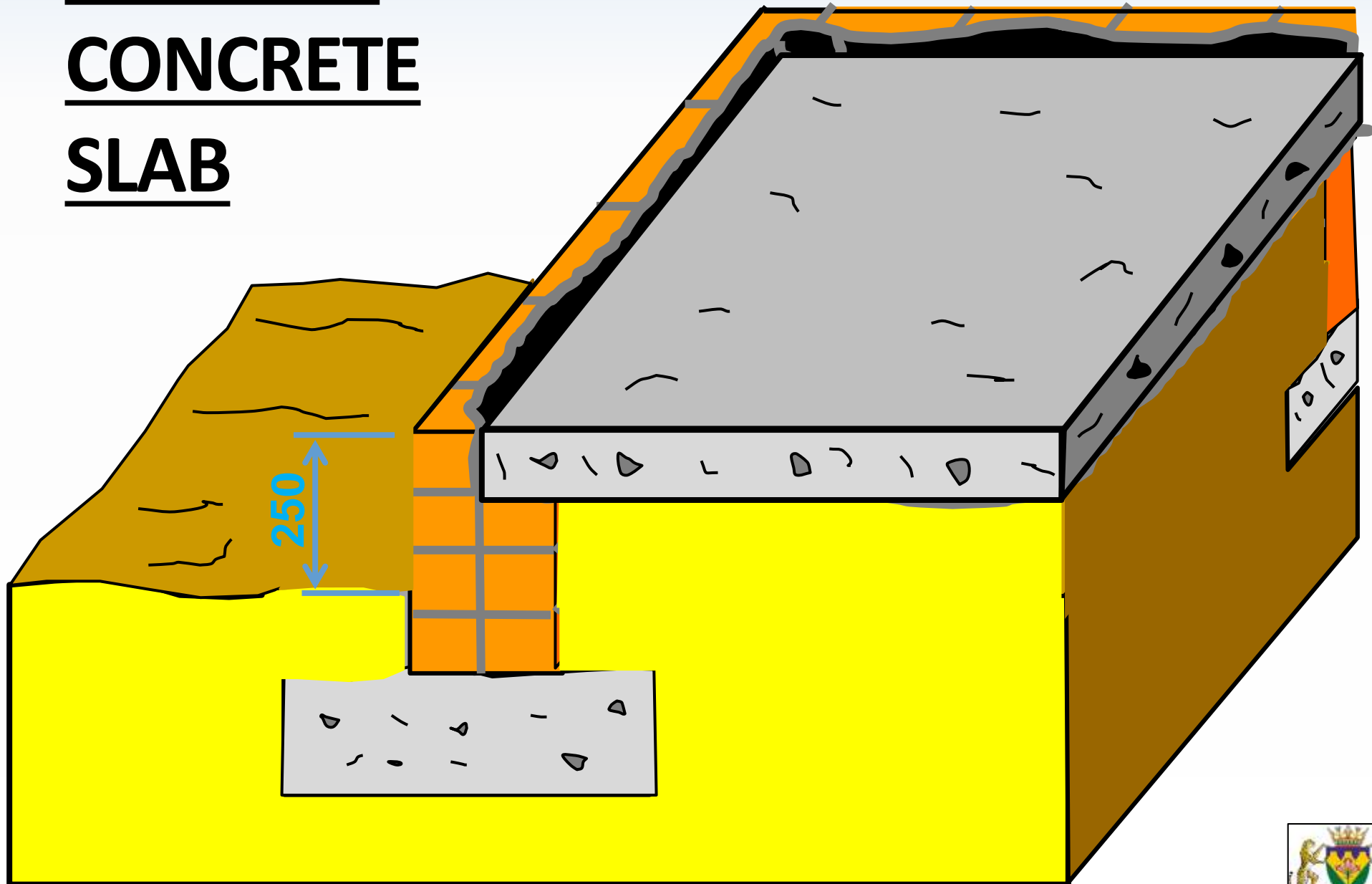

CASTING THE CONCRETE SLAB



CASTING THE CONCRETE SLAB



CASTING THE CONCRETE SLAB

- Load bearing walls

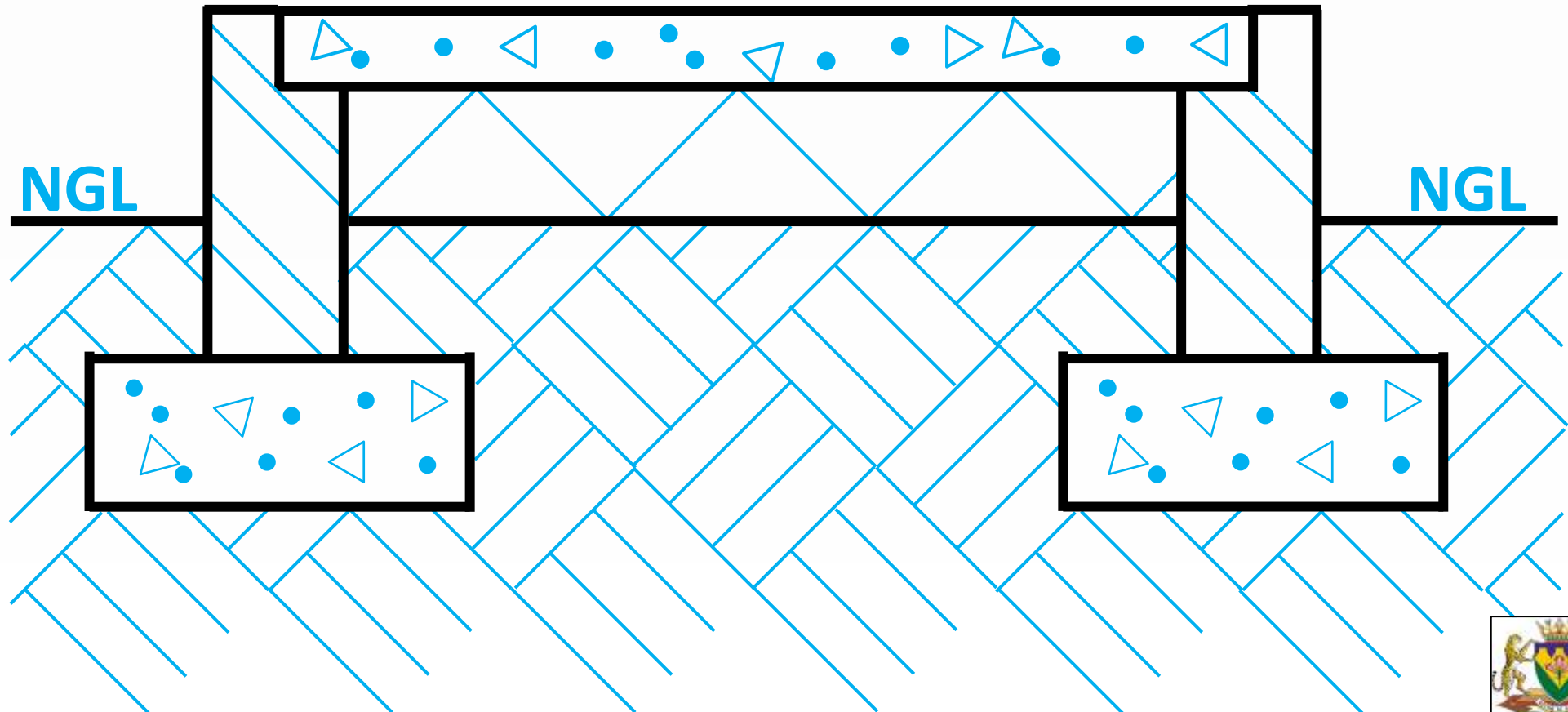

CASTING THE CONCRETE SLAB

- Load bearing & non-load bearing walls

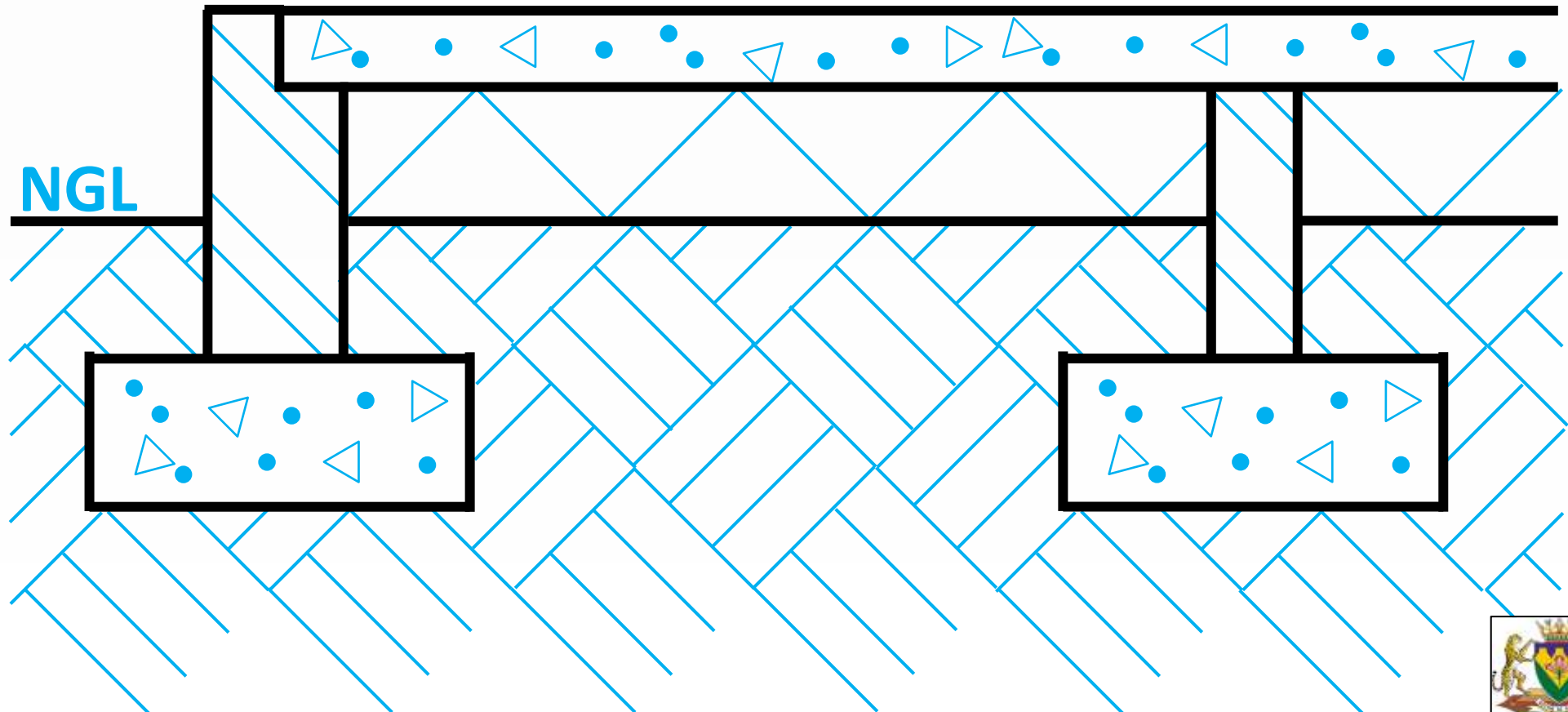

FLOATING

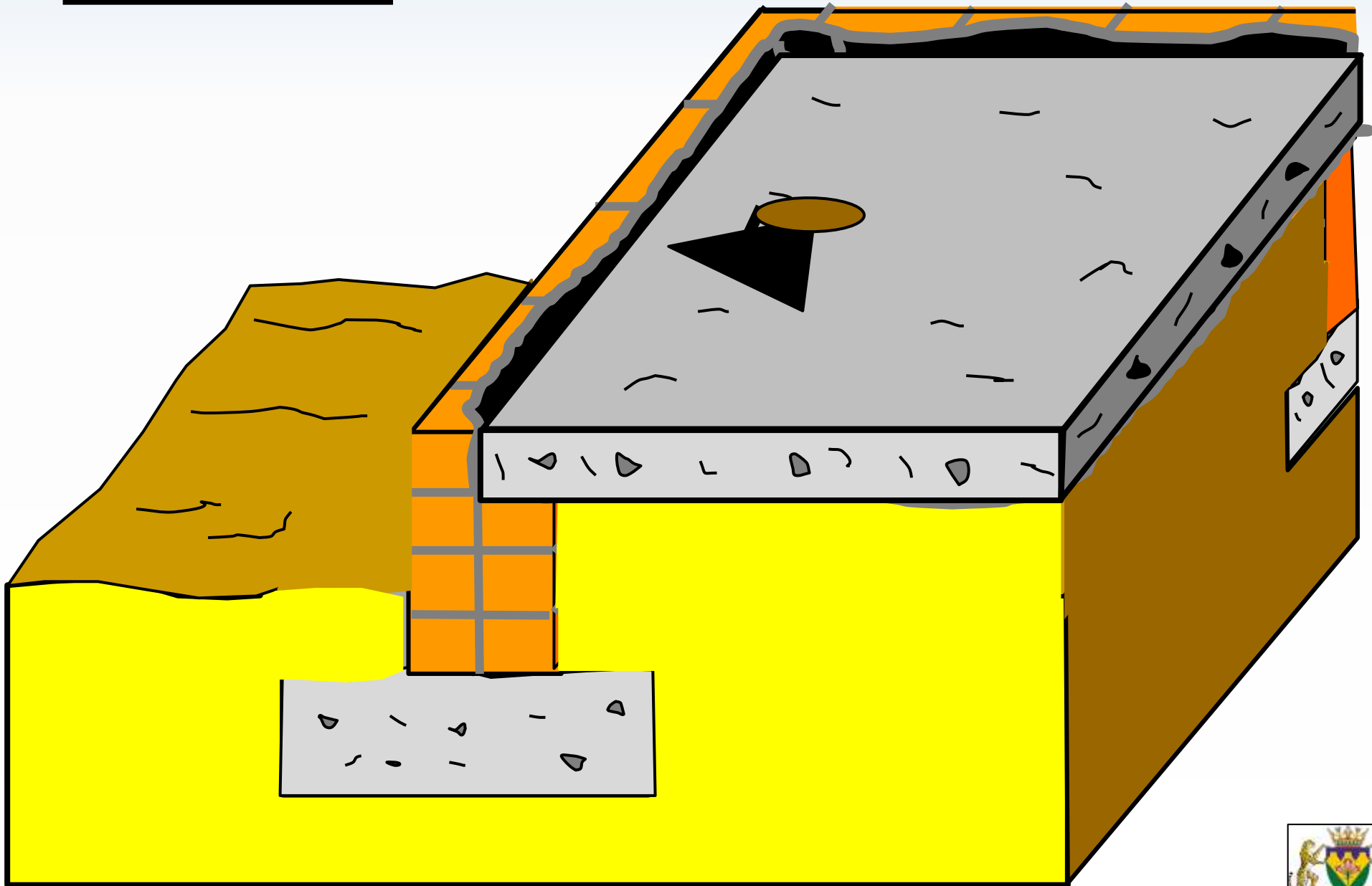

CASTING THE CONCRETE SLAB



FLOATING



DPC (DAMP
PROOF
COURSE)

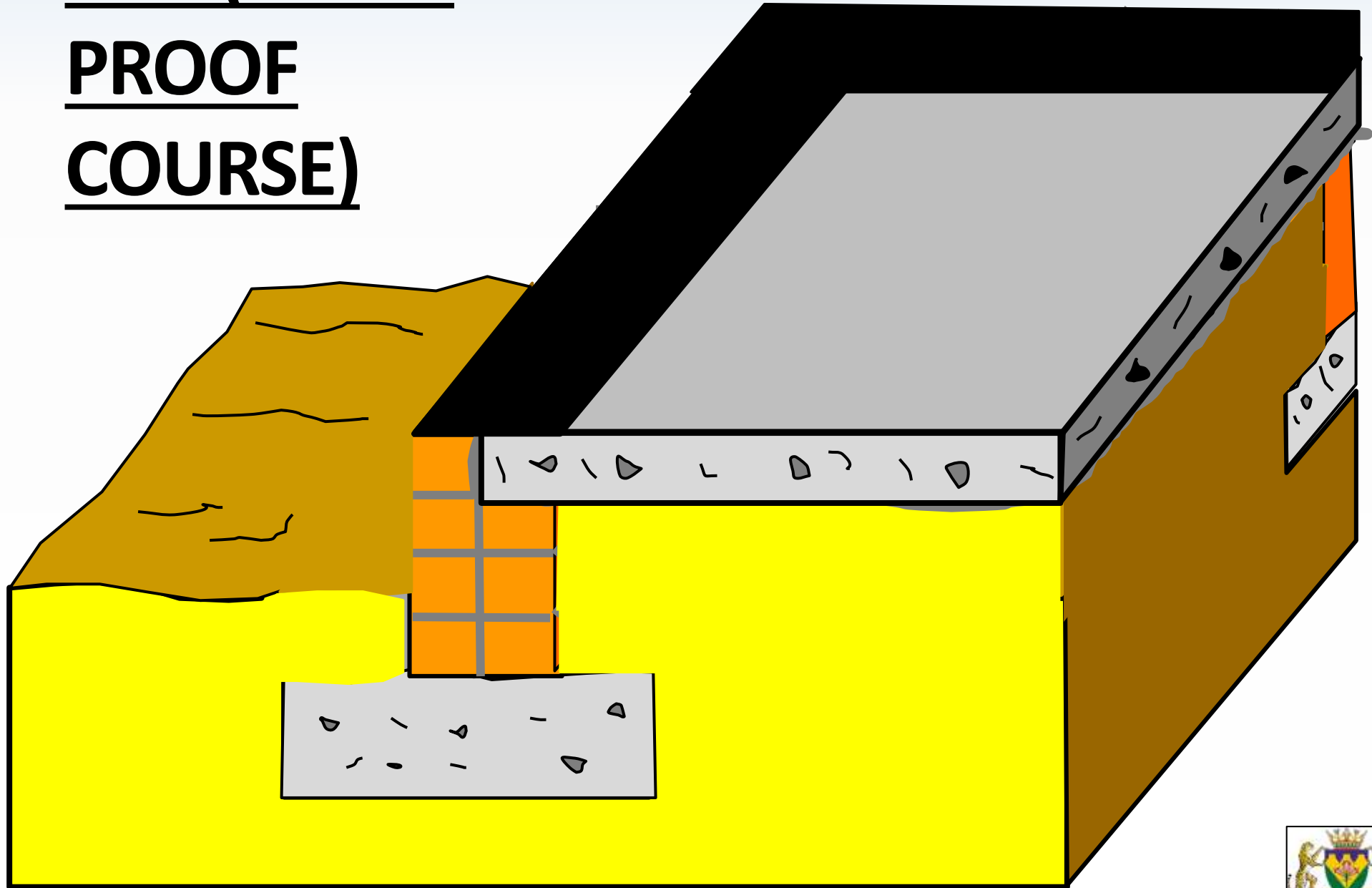

DAMP PROOF COURSE (DPC)



DAMP PROOF COURSE (DPC)

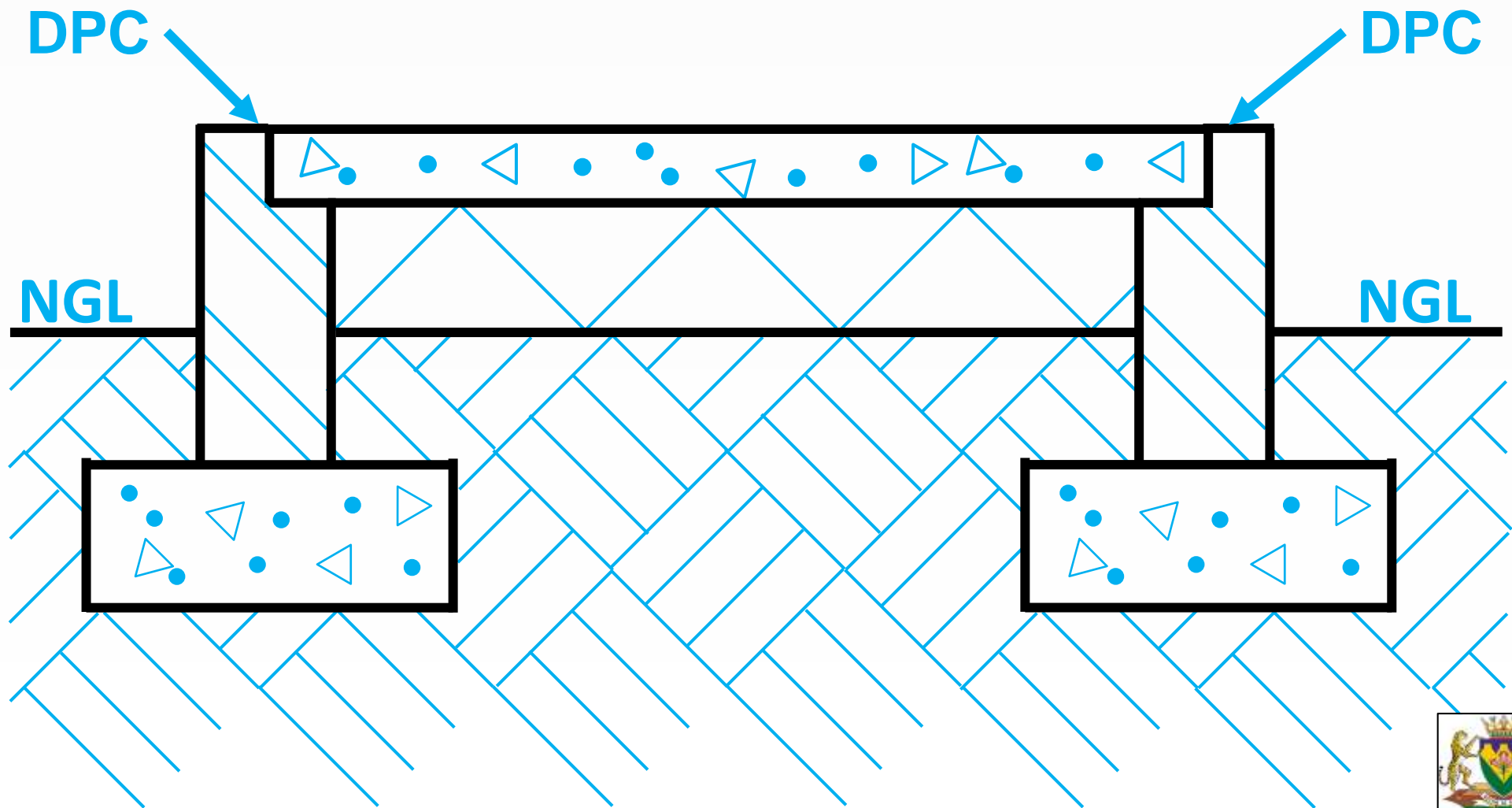

DAMP PROOF COURSE (DPC)

- Load bearing & non-load bearing walls

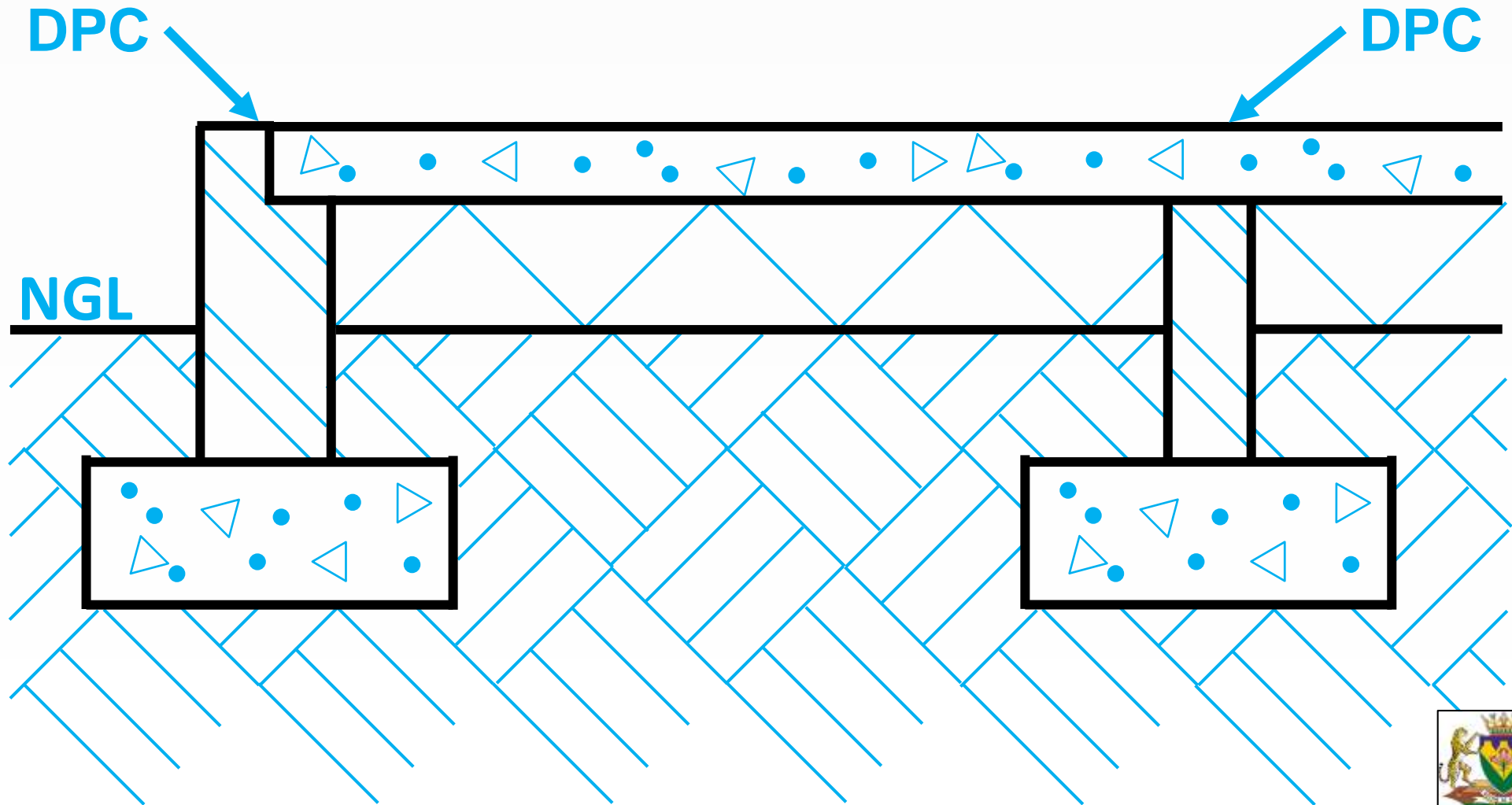

BUILDING
WALLS ON
DPC

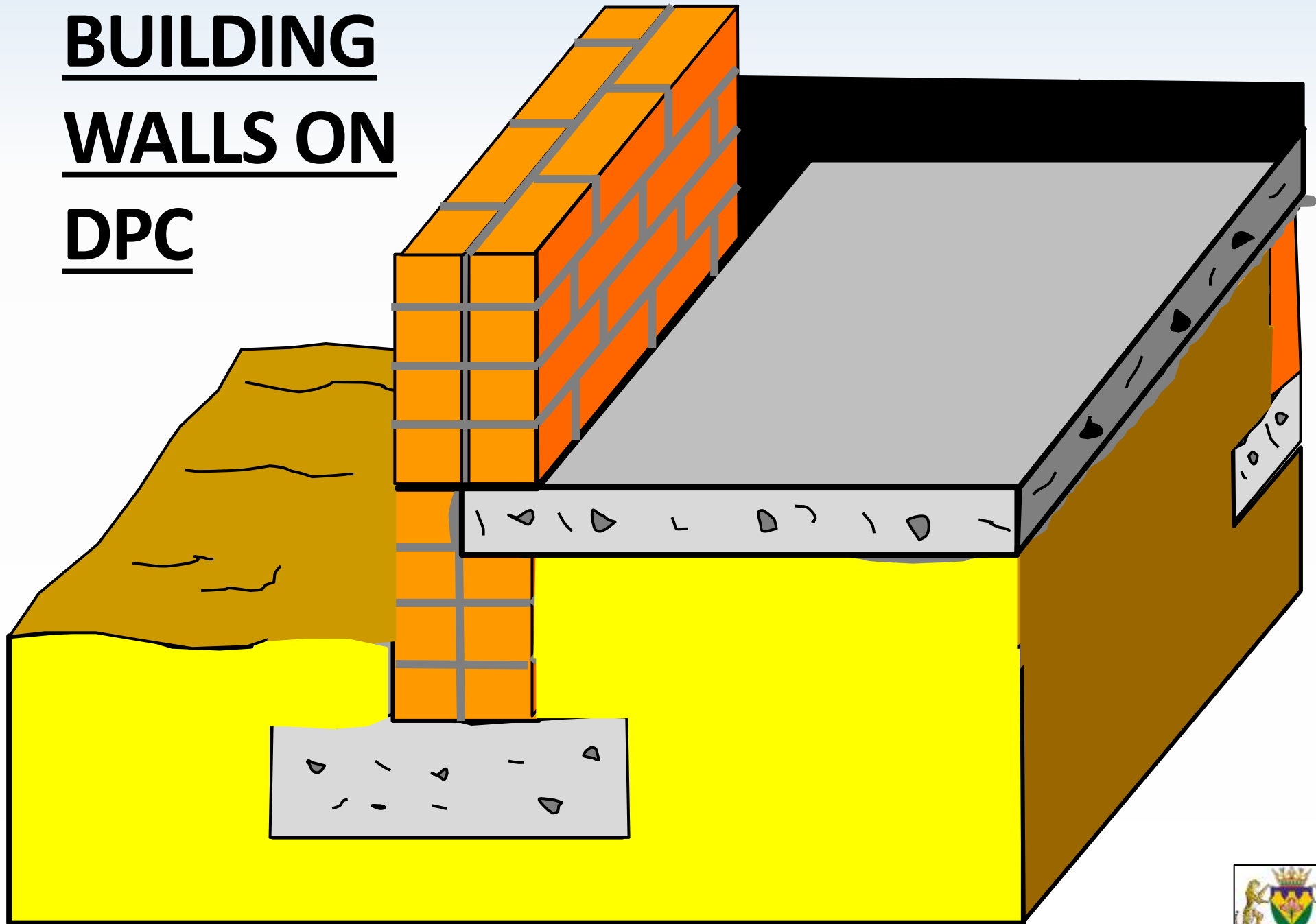

CAS



BUILDING ON DAMP PROOF COURSE (DPC)

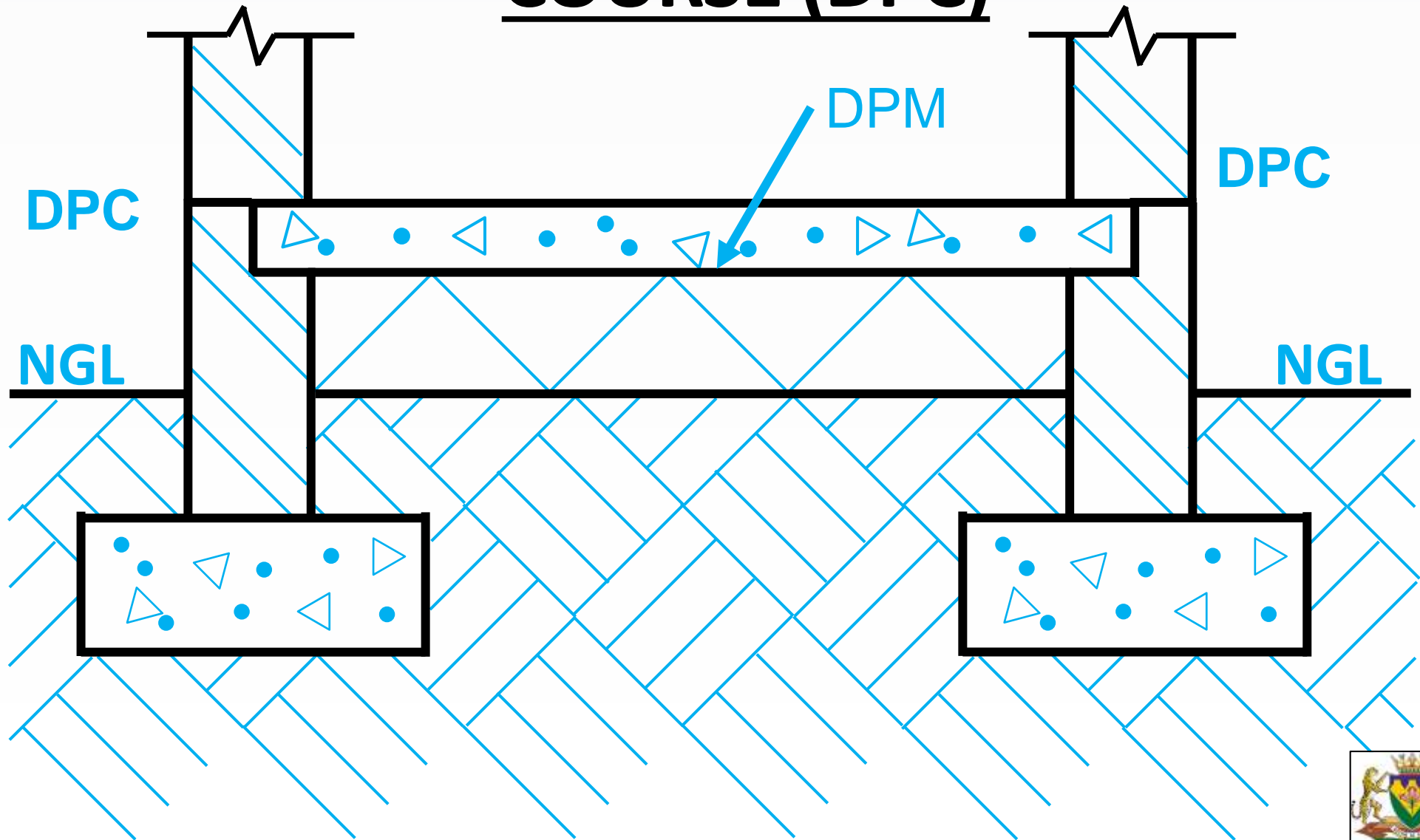

BUILDING ON DAMP PROOF COURSE (DPC)

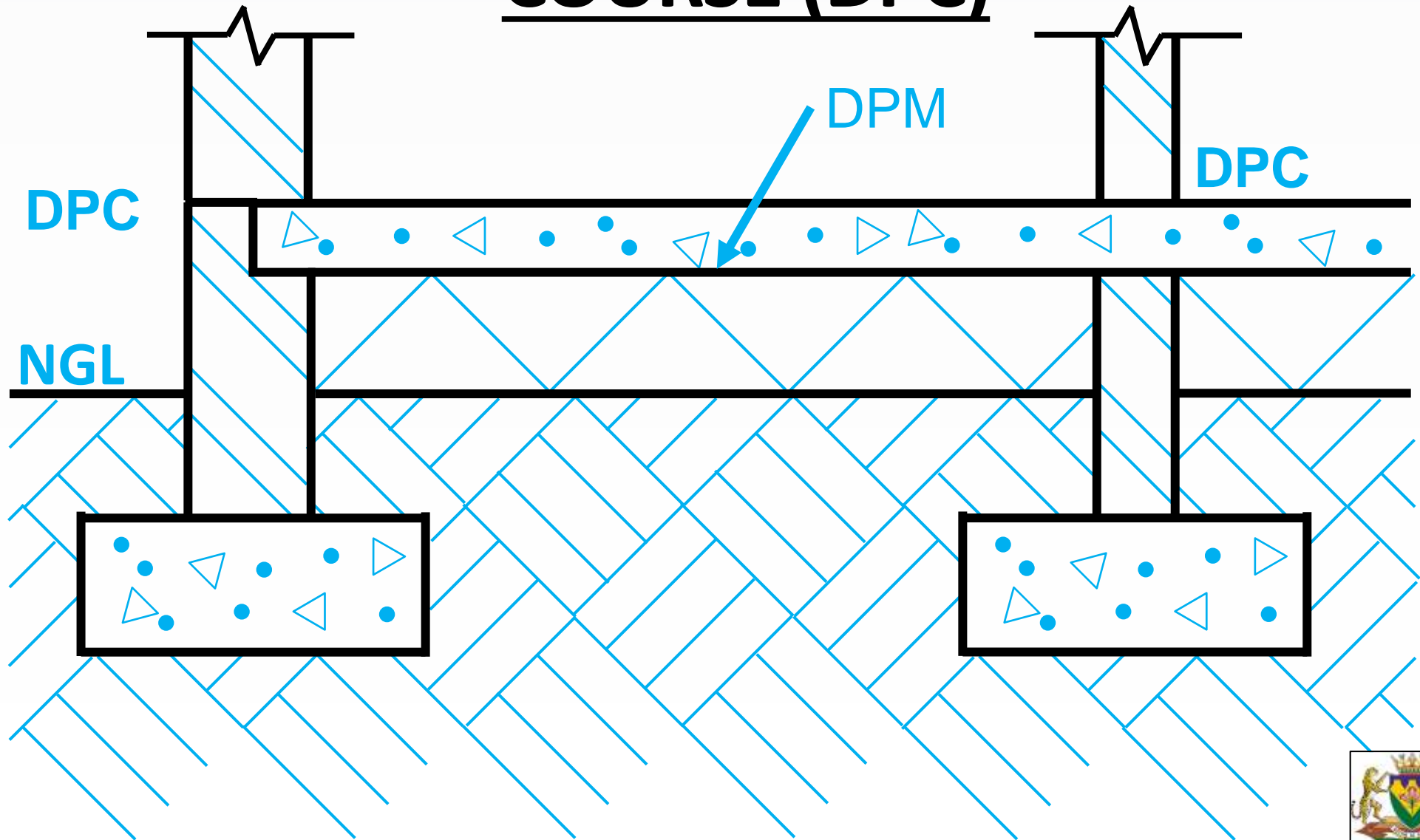

SCREED



SCREED

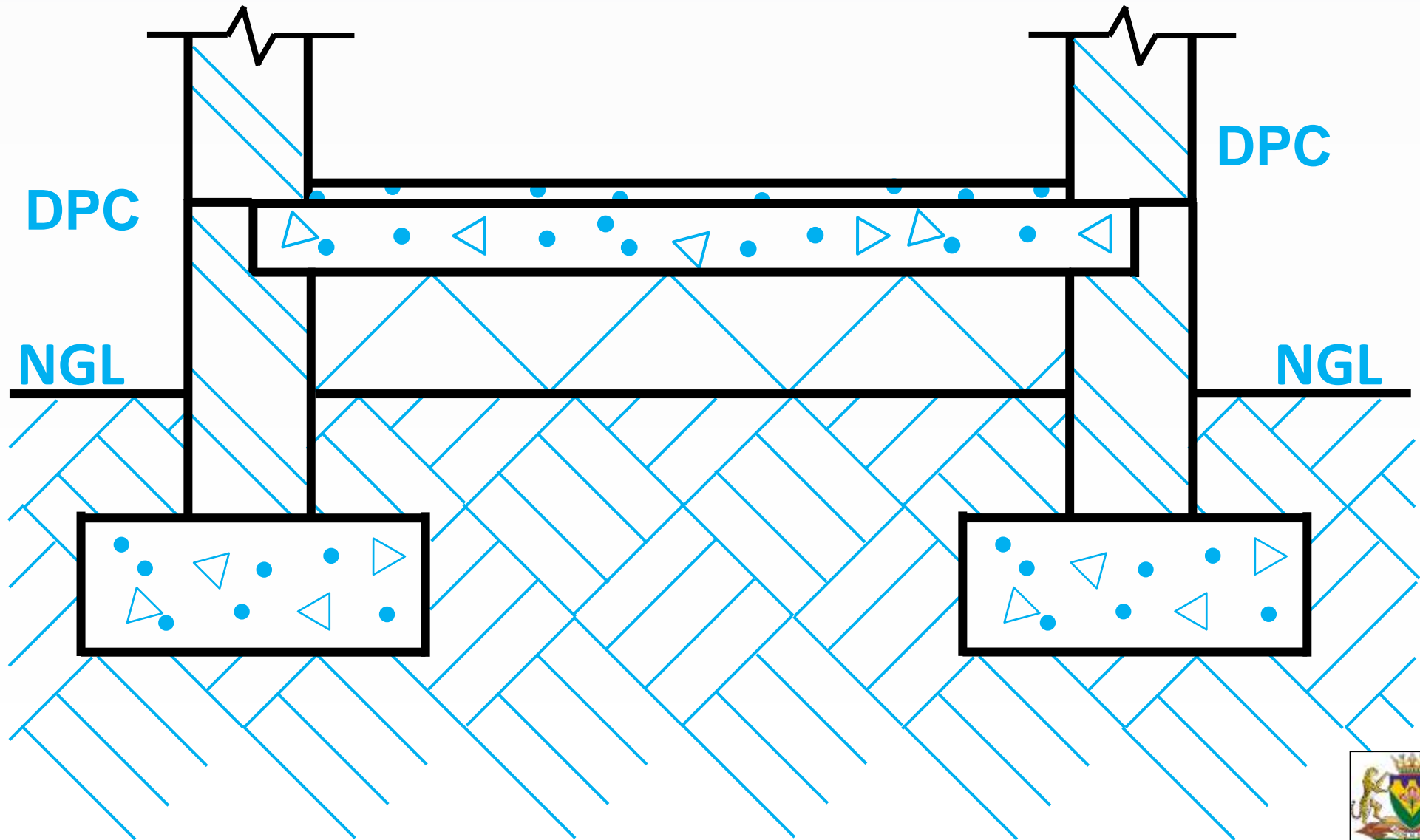

SCREED

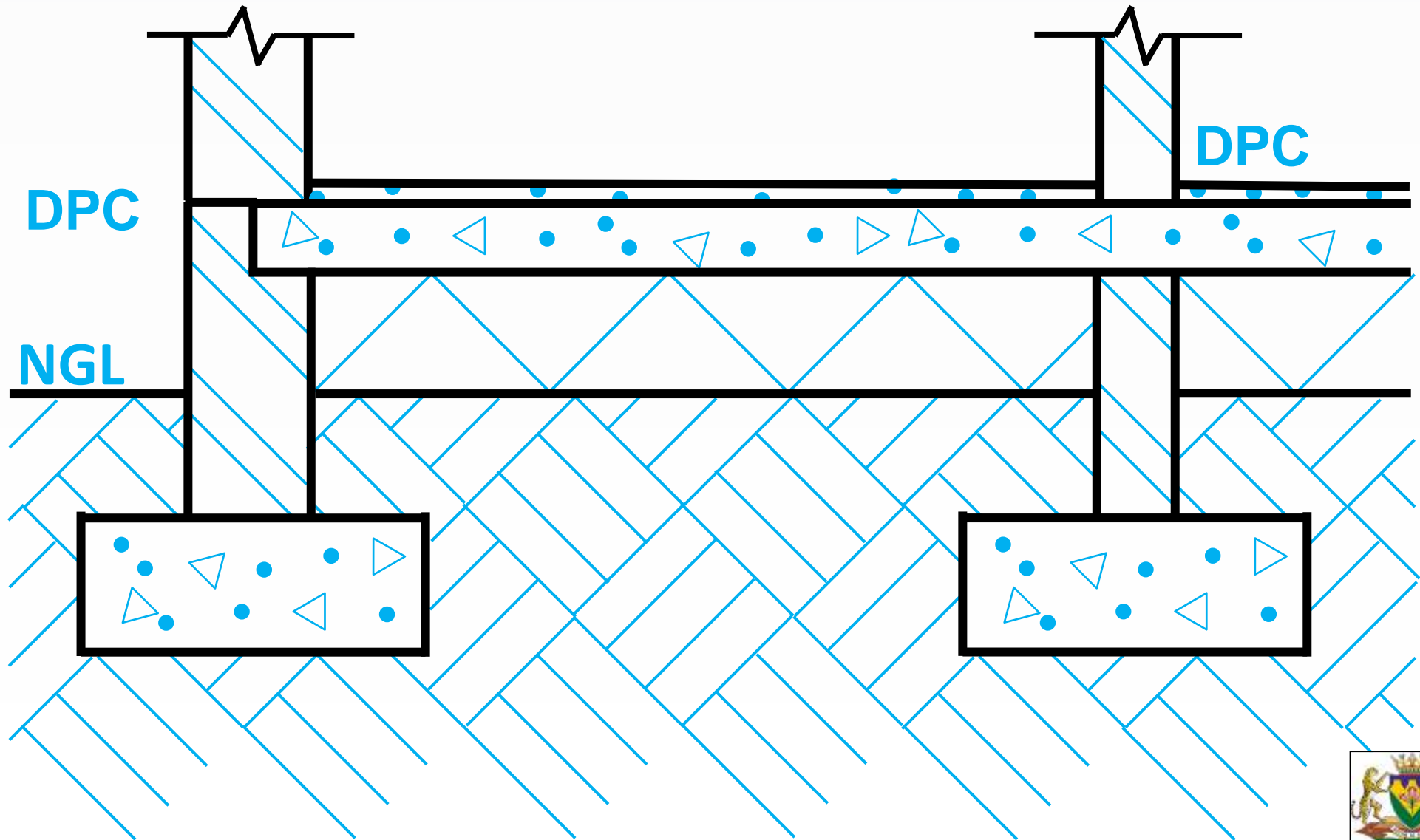

DOORS

STANDARD WOODEN DOOR

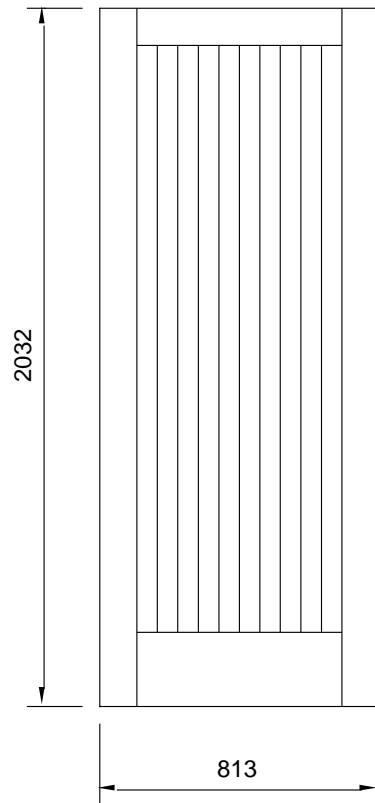

STANDARD GARAGE DOOR

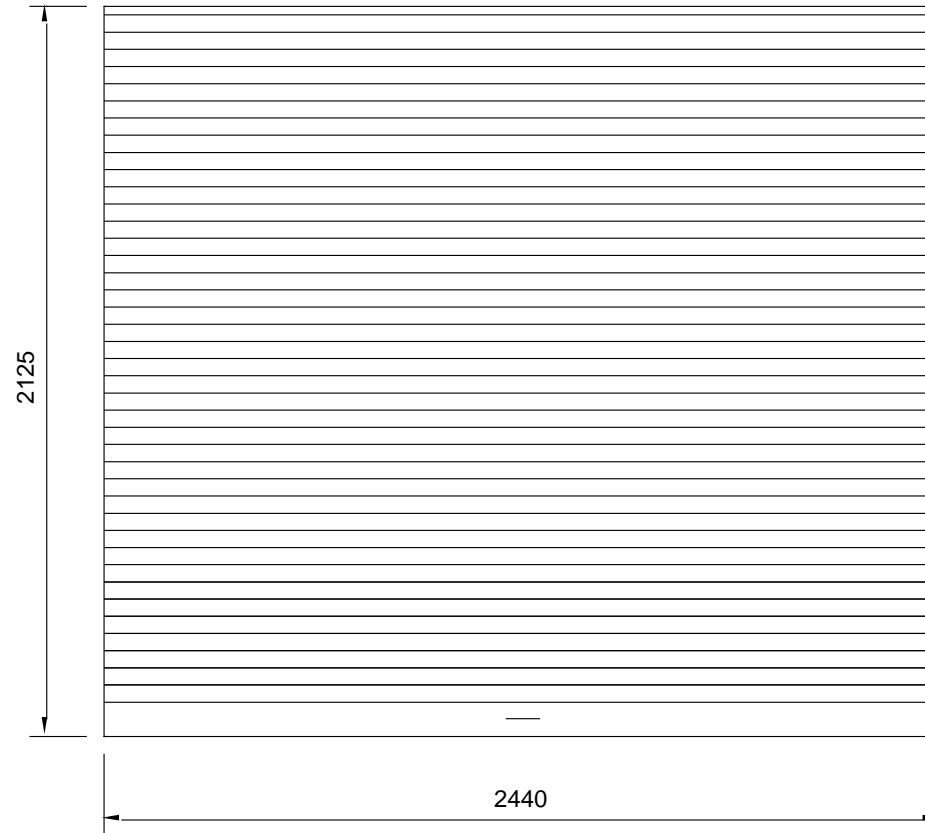

DOORS

SLIDING DOORS

WOODEN

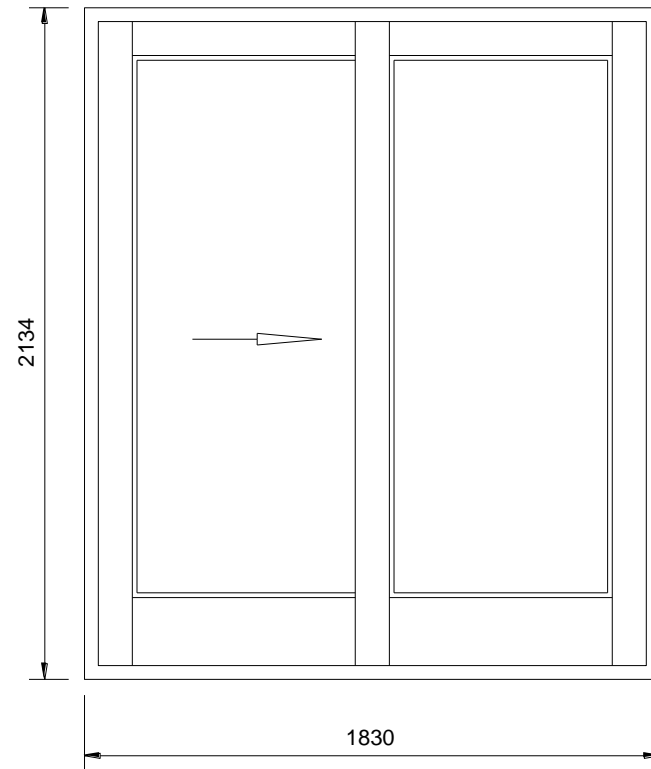

SIZES AVAILABLE

1830 x 2134
2430 x 2134
3048 x 2134
3658 x 2134

ALUMINIUM

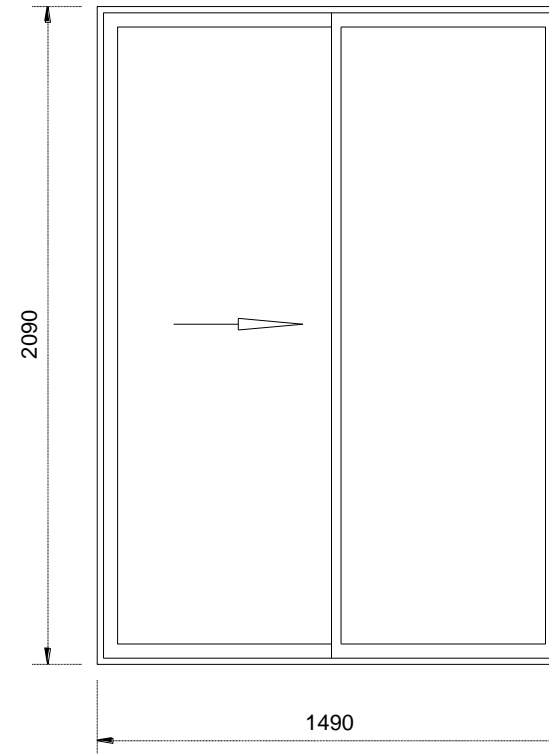

SIZES AVAILABLE

1490 x 2090
1790 x 2090
2090 x 2090
2390 x 2090
2990 x 2090

A STEEL DOOR FRAME



SINGLE REBATED STEEL DOOR FRAME

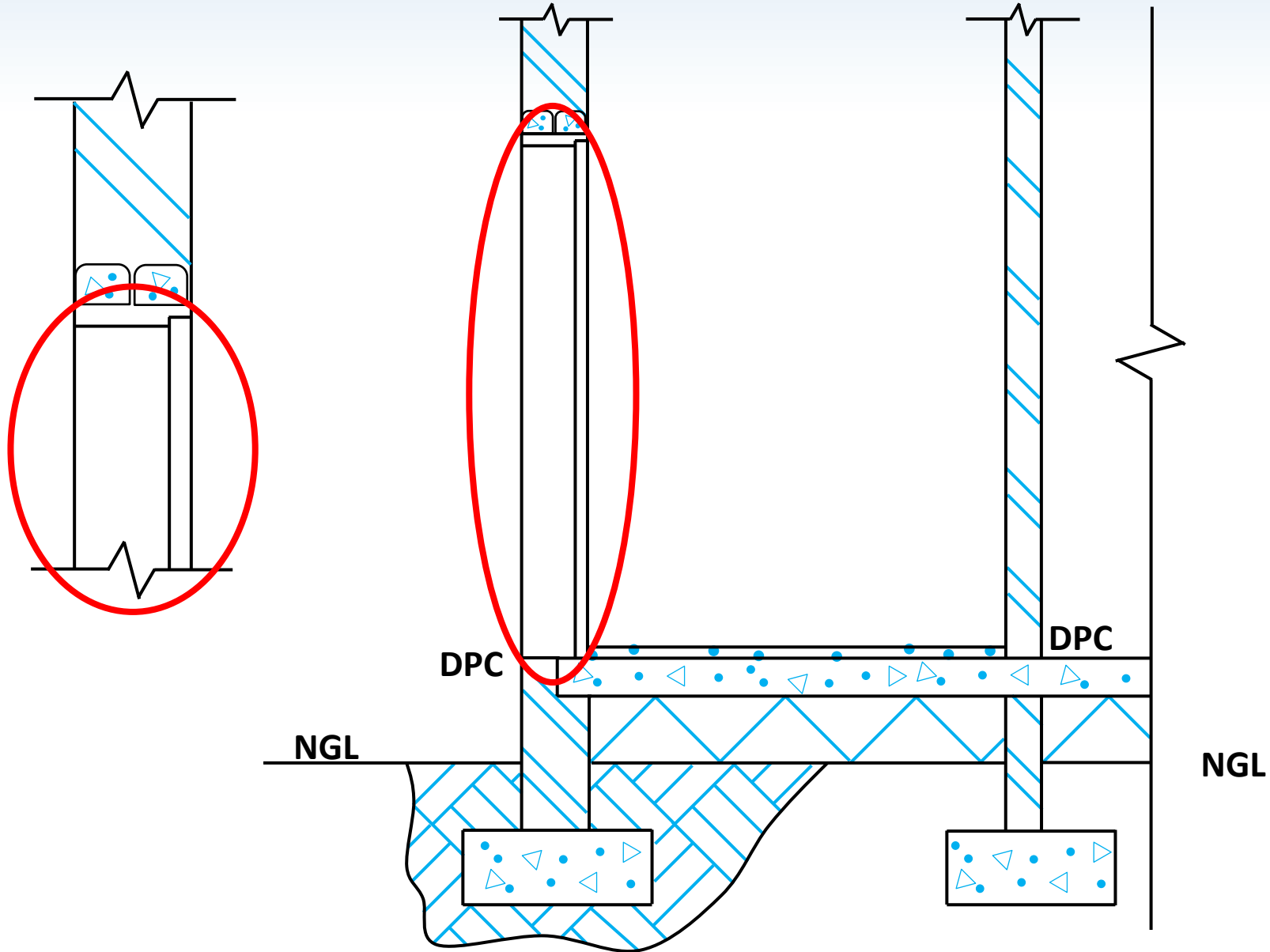

DOUBLE REBATED STEEL DOOR FRAME

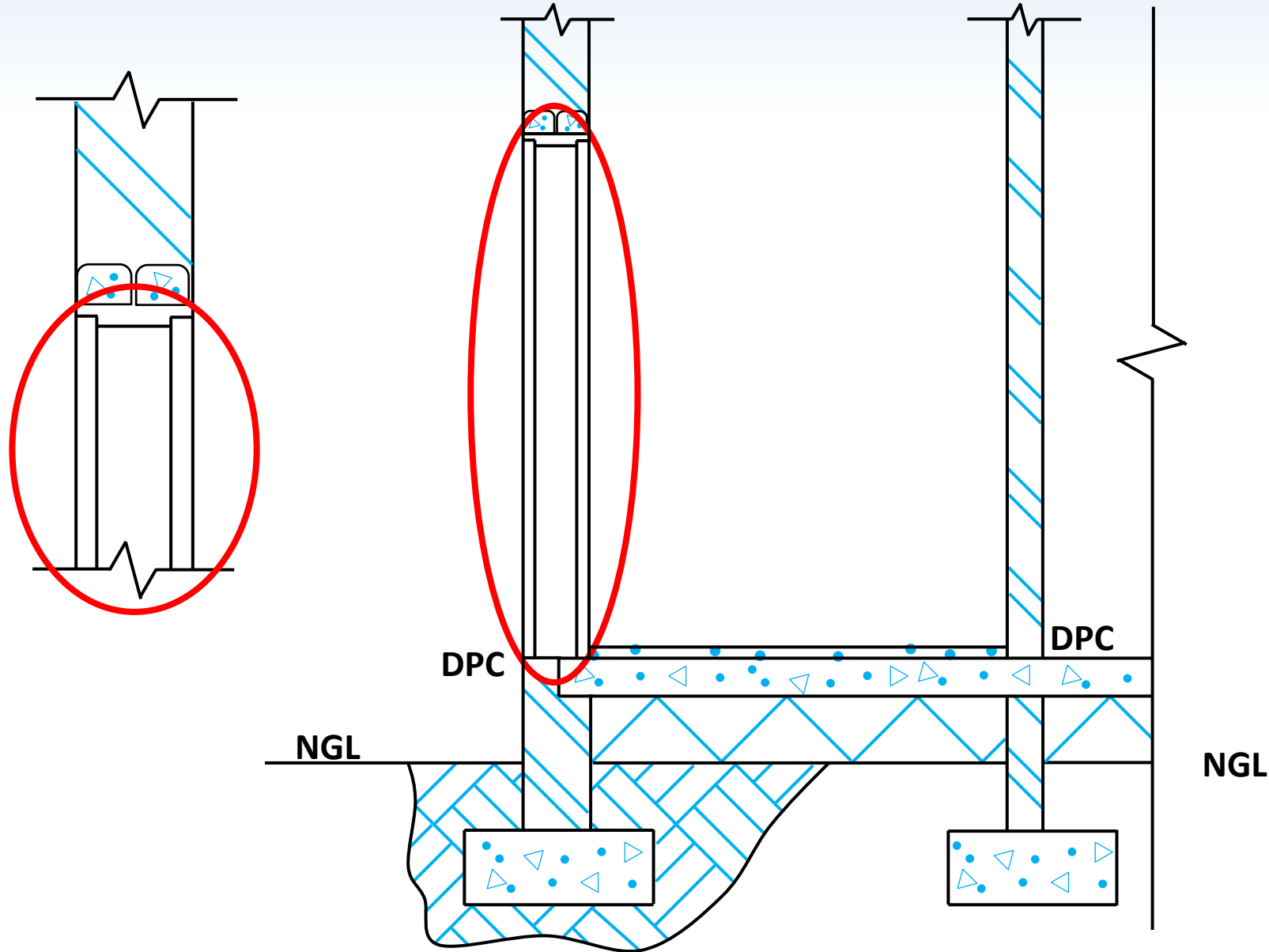

WOODEN DOOR FRAMES

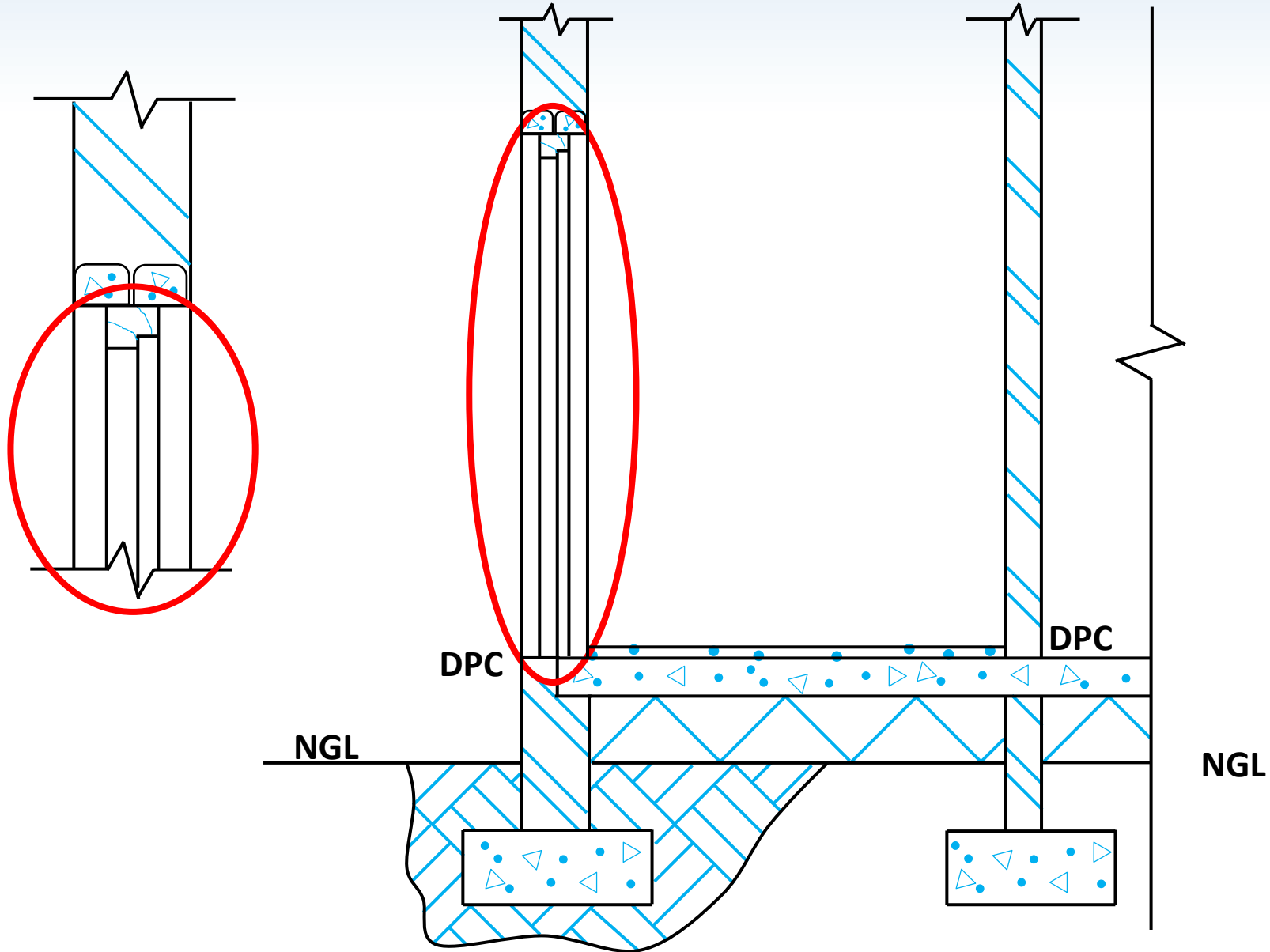

ALUMINIUM DOOR FRAMES

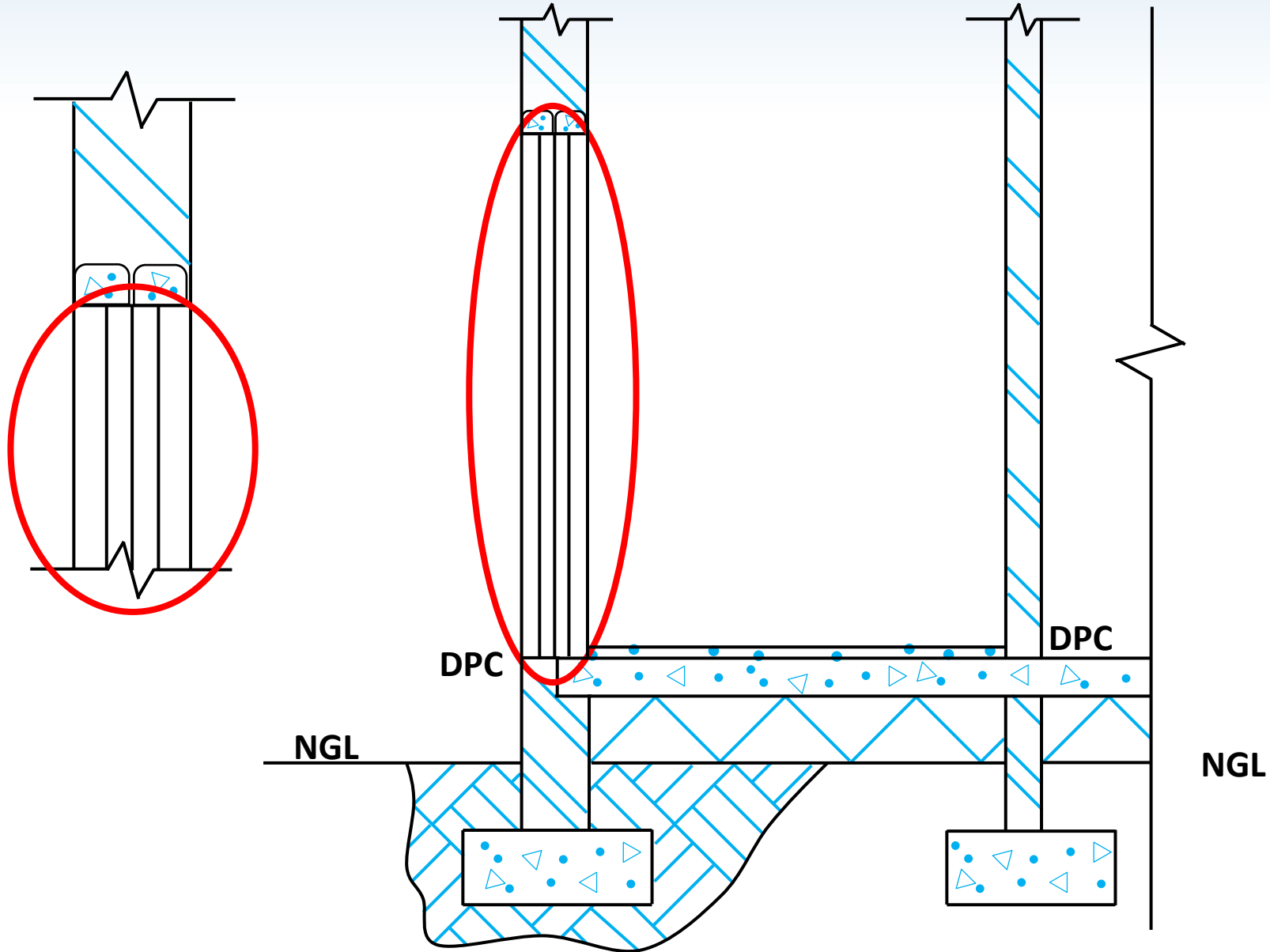

WINDOWS

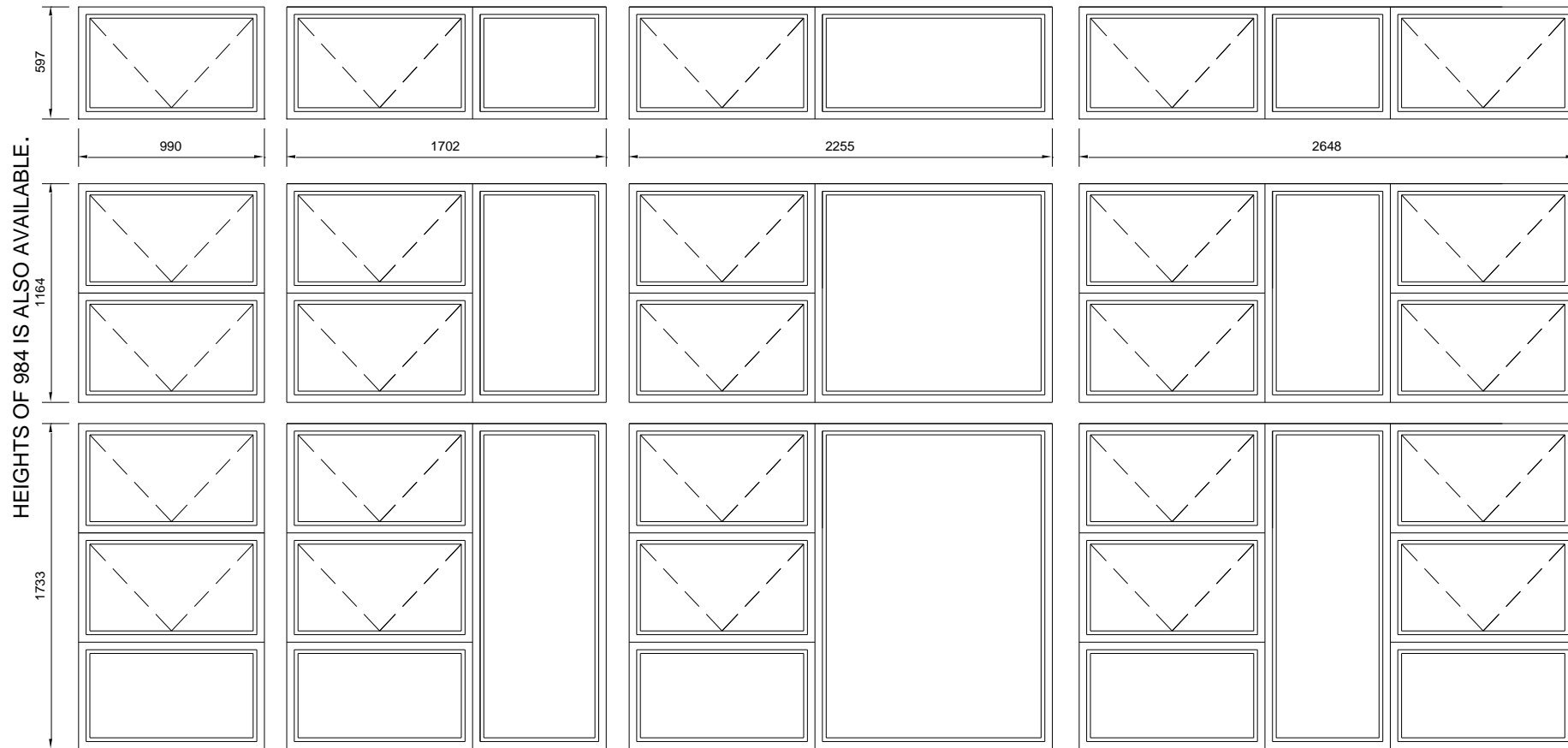

WIDTHS OF 3200 IS ALSO AVAILABLE.

WINDOWS

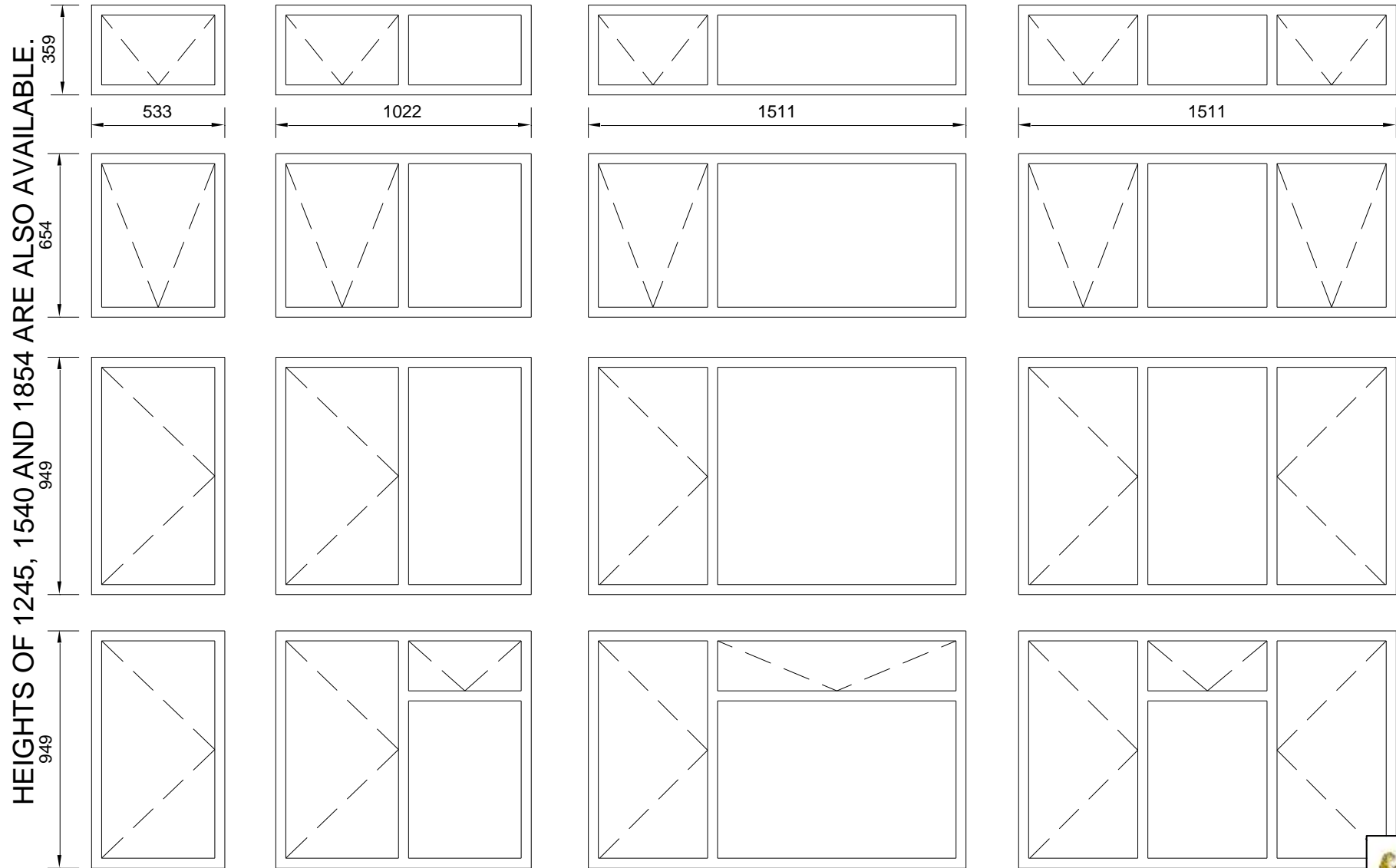

WIDTHS OF 305, 2000 AND 2489 ARE ALSO AVAILABLE.

VENTILATION AND ILLUMINATION

- Any room must have a window.
 - Minimum of 10% of the floor area
 - 5% must be able to open
 - Must have cross ventilation
 - The door and window not allowed to the same wall
 - The top of the window and the top of the door should be at the same level

DPC BELOW THE WINDOWS



DPC, WINDOW SILL AND WINDOW FRAME

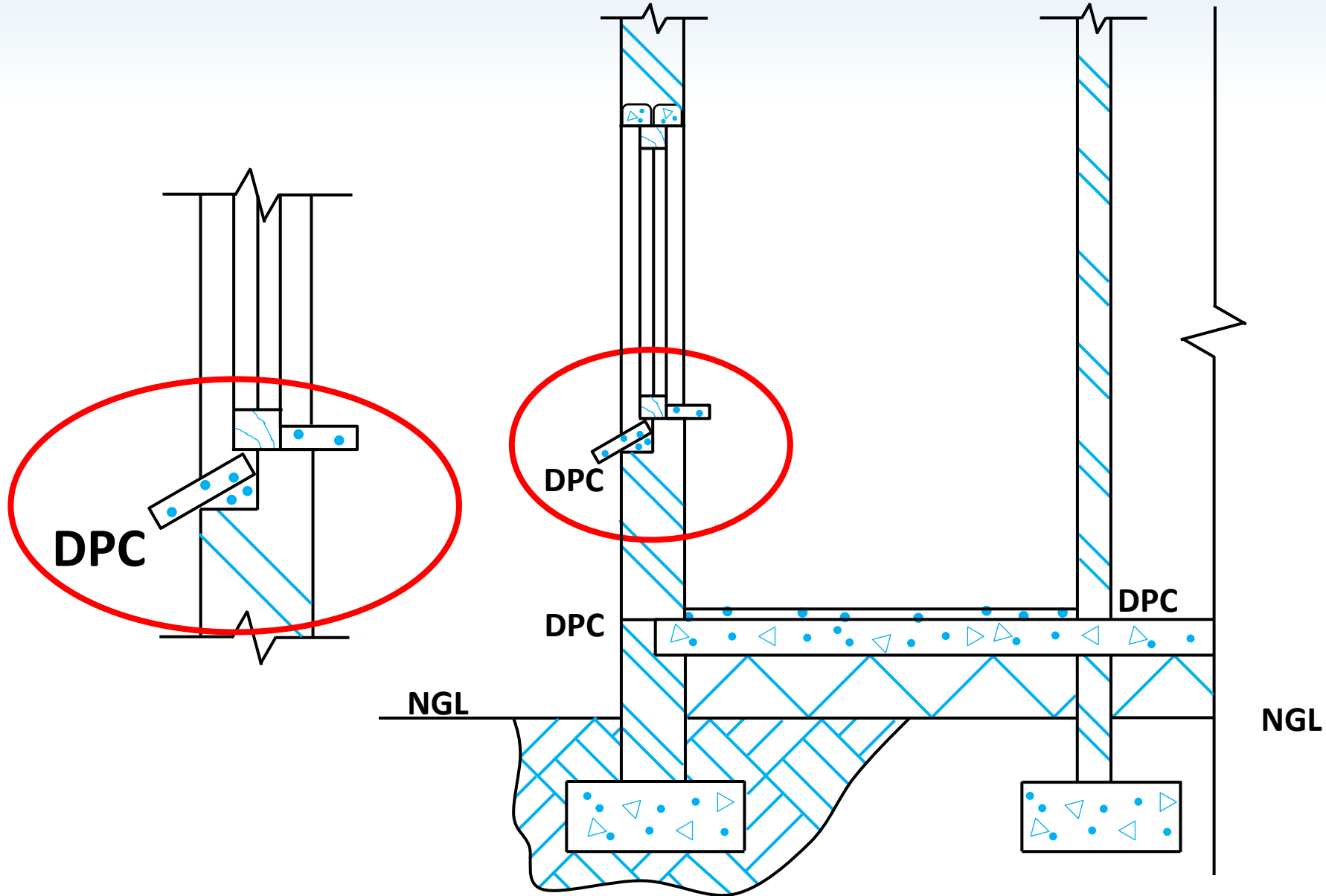

WINDOW LINTEL



WINDOW LINTEL AND WINDOW FRAMES

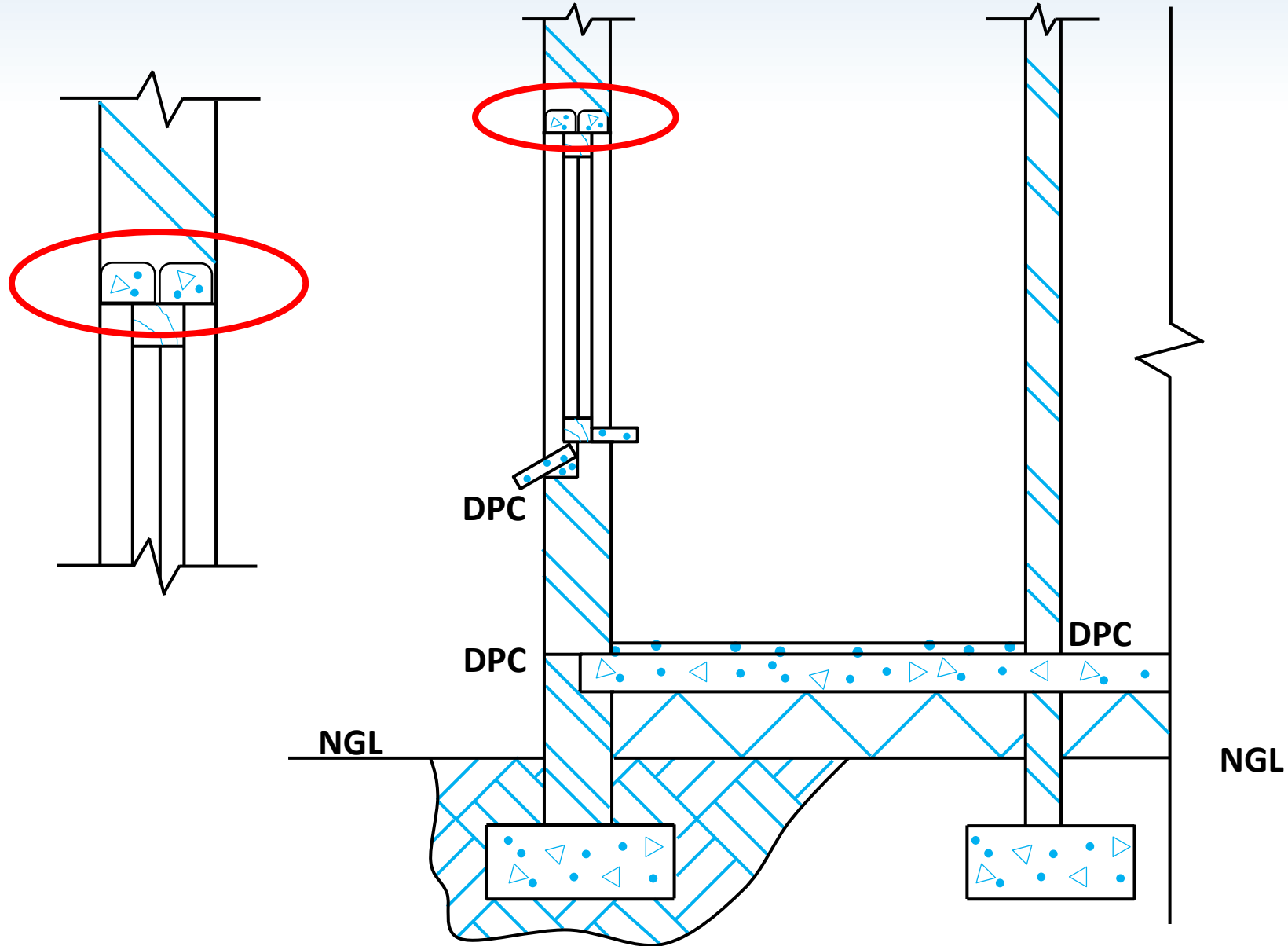

REQUIRED HIEGHTS ON A SECTIONED VIEW

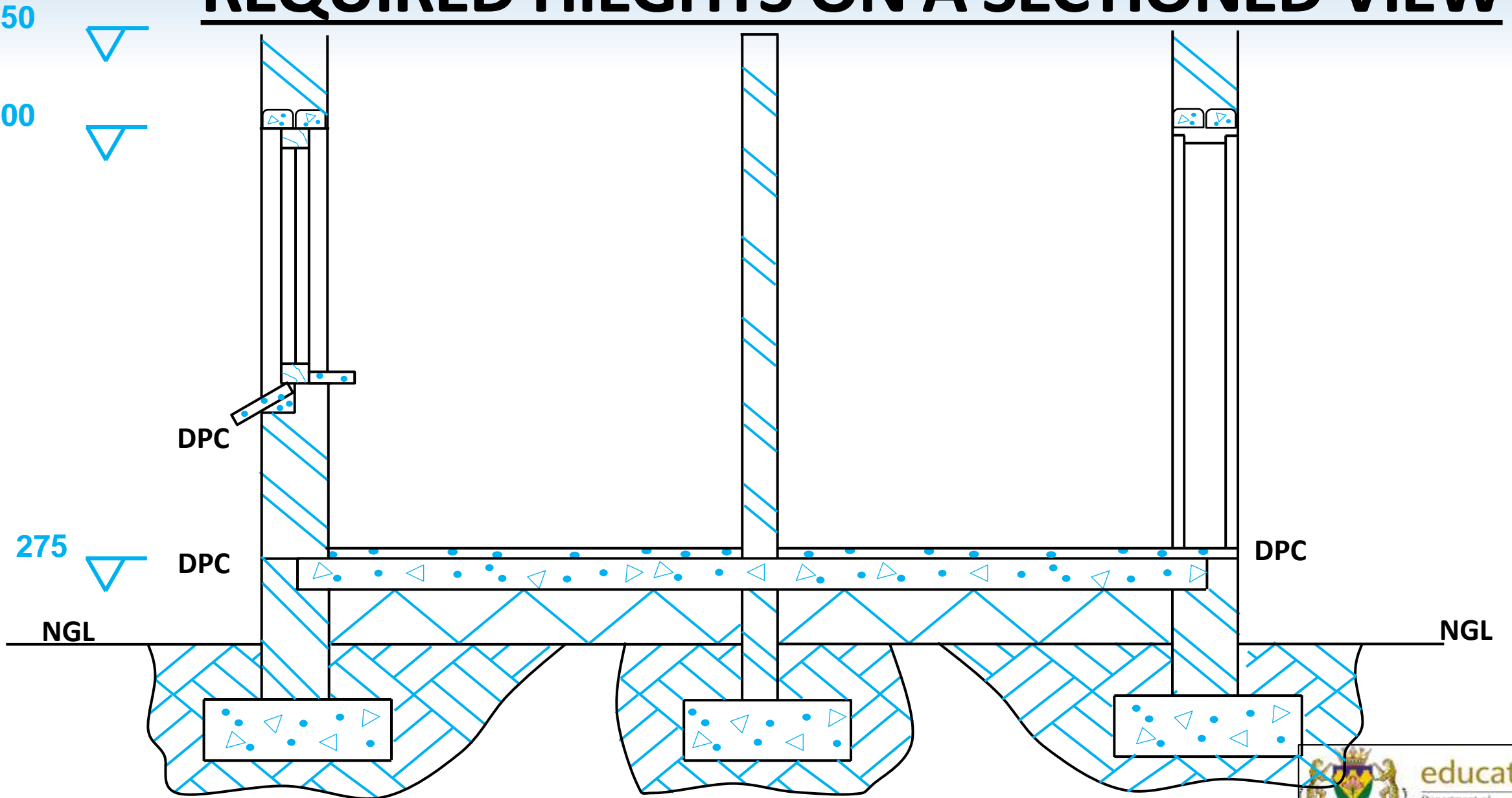

ALWAYS SECTION THROUGH A DOOR & WINDOW

