

education

Department of Education
FREE STATE PROVINCE

PROVINSIALE VRAESTEL
PROVINCIAL PAPER

GRAAD 11
GRADE 11

INGENIEURSGRAFIKA EN -ONTWERP V1
ENGINEERING GRAPHICS AND DESIGN P1

JUNIE 2018 / JUNE 2018

PUNTE / MARKS: 100
TYD: 3 UUR / TIME: 3 HOURS

Hierdie vraestel bestaan uit 6 bladsye. / This paper consists of 6 pages.

INSTRUKSIES EN INLIGTING

- Hierdie vraestel bestaan uit VIER vrae
- Beantwoord AL die vrae.
- ALLE tekeninge is in eerstehoekse ortografiese projeksie, tensy anders aangedui.
- ALLE tekeninge moet volgens skaal 1:1 geteken word, tensy anders aangedui.
- AL die vrae moet, soos voorgeskryf, op die DIAGRAMVELLE beantwoord word.
- AL die bladsye moet weer in nommervolgorde vasgekram word, ongeag of die vraag beantwoord is of nie.
- Tydsbeplanning is noodsaaklik om al die vrae te voltooi.
- Drukskryf jou naam en van asook die graad in die spasie wat voorsien is op elke bladsy.
- ALLE antwoorde moet akkuraat en netjies geteken word.
- Alle nodige konstruksie- en projeksielyne moet getoon word.
- Beplan elke tekening noukeurig vanaf die beginposisie wat op die diagramvelle aangedui is.
- Enige besonderhede of afmetings wat nie gegee is nie, moet in goeie verhouding beraam word.

INSTRUCTIONS AND INFORMATION

- This question paper consists of FOUR questions
- Answer ALL the questions.
- ALL drawings are in first-angle orthographic projection, unless stated otherwise.
- ALL drawings must be drawn to scale 1:1, unless stated otherwise.
- ALL questions must be answered on the DIAGRAM SHEETS as instructed.
- ALL the pages must be restapled in numerical sequence, irrespective of whether the question was attempted or not.
- Time management is essential in order to complete all the questions.
- Print your name and surname as well as the grade in the space provided on each page.
- All answers must be drawn accurately and neatly.
- All necessary construction and projection lines must be shown.
- Plan each drawing carefully from the given position, which is indicated on the diagram sheets.
- Any details or dimensions not given must be assumed in good proportion.

SLEGS VIR AMPTELIKE GEBRUIK FOR OFFICE USE ONLY							
PUNTE / MARKS				MODEREER MODERATE			
1							
2							
3							
4							
TOTAAL TOTAL							
	1	7	5				

FINALE PUNT FINAL MARK	NAGESIEN CHECKED
100	

NAME AND SURNAME NAAM EN VAN	GRADE GRAAD

QUESTION 1: ANALYTICAL (CIVIL)

GIVEN: The floor plan and elevation of a house, a title panel and table of questions. The drawing has not been prepared to the indicated scale.

INSTRUCTIONS: Complete the table below by neatly answering the questions, which refer to the accompanying drawing and title panel.

Show all calculation where applicable.

[24]

QUESTIONS		ANSWERS	Mark	Obtained	Moderated
1	How many signatures are required?	2	1		
2	How many doors are shown on the plan?	4	1		
3	How many different sized windows are shown on the plan?	4	1		
4	What is the scale indicated on the drawing?	Skaal 1:100	1		
5	How many different floor finishes are indicated on the drawing?	3	1		
6	What does number 1 indicate?	Window can open	1		
7	What does number 2 indicate?	FFL	1		
8	What does number 3 indicate?	NGL	1		
9	What does number 4 indicate?	Stair (step)	1		
10	What is the abbreviation for the fixture numbered 5?	BIC	1		
11	What does number 6 indicate?	Room designation	1		
12	What does number 7 indicate?	Direction North	1		
13	What does number 8 indicate?	Direction to open	1		
14	What would VIEW 1 be called?	Plan (floor plan)	1		
15	What would VIEW 2 be called?	South elevation	1		
16	In what SI unit are the dimensions given in?	Millimeters	1		
17	What type of brick is used to build the load bearing walls?	Common brick	1		
18	In the space provided determine the perimeter of the dwelling in metres.	95.2m	3		
19	Draw, in the space of the answer column, in neat free hand, the front view and top view of the SANS 10143 symbol for a WC.	($\frac{8}{2}$)= 4			
TOTAAL			24		

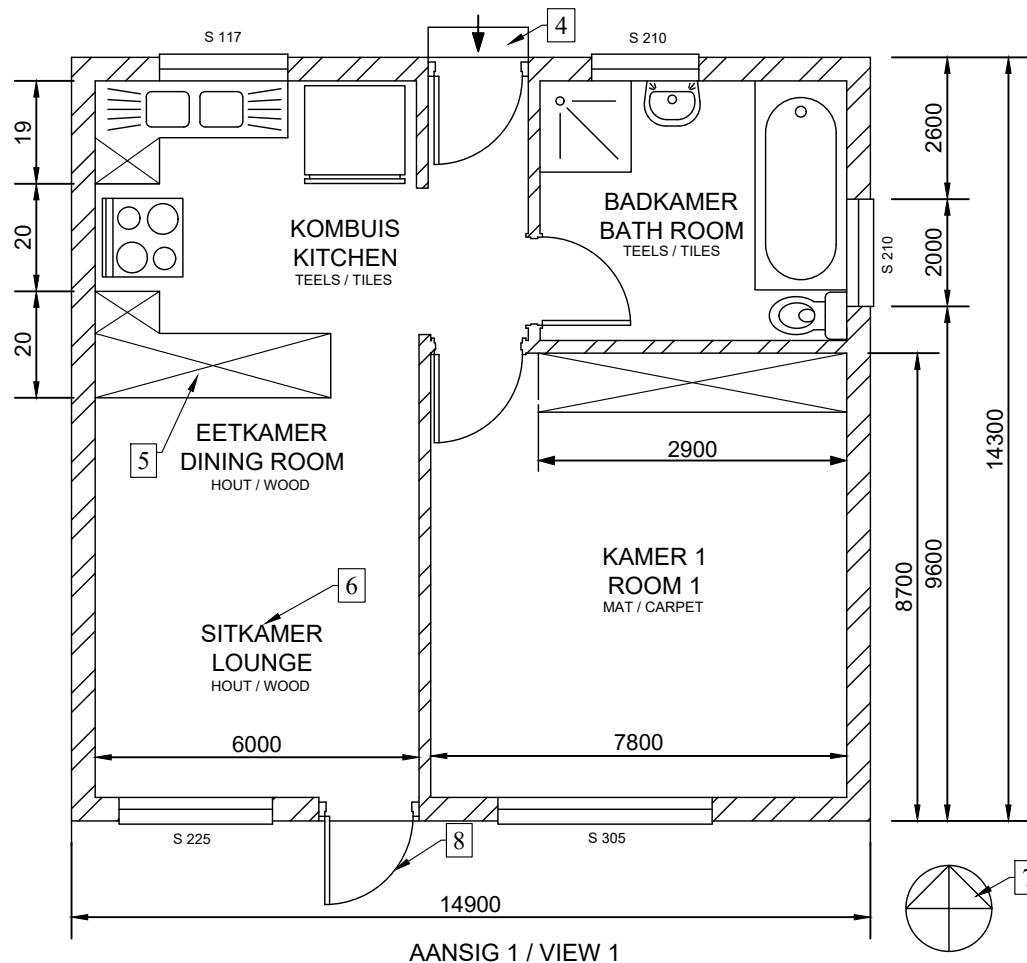
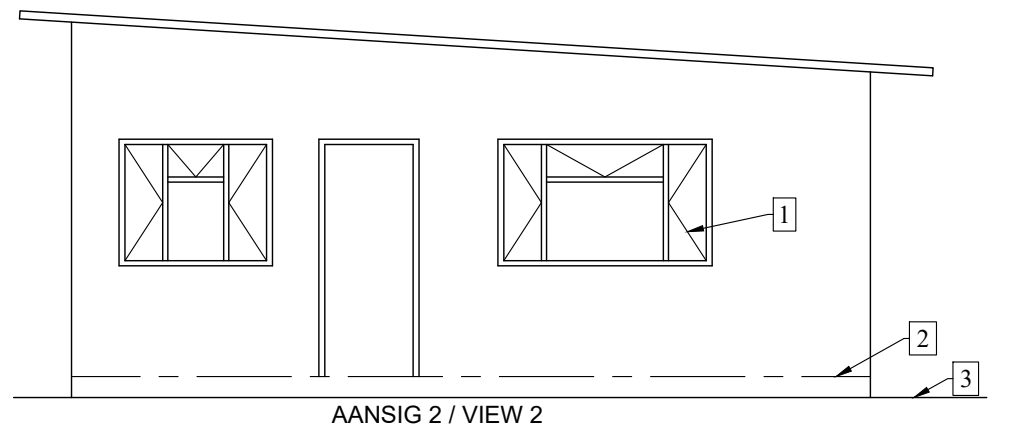

DRAWING INFORMATION	
Note: Contractors must verify all dimensions and levels on site before commencing work. Architects to be notified immediately of any discrepancies.	PRINTED BY: PRESSCOR DATUM: 9/9/2015
	CHECKED BY: RAE DATE: 14/10/2015
ARCHITECT'S SIGNATURE:	APPROVED BY: ERICK DATUM: 7/11/2015
CLIENT'S SIGNATURE:	SKAAL: 1:100

Title: FLOOR PLAN - GOLDEN YEARS RETIREMENT	Project: PROPOSED NEW HOUSING UNITS AT AN OLD AGE HOUSE PLOT 3, RHINO AVENUE
FILE NAME: HG-03-2016	
Perfect Architect AND DRAUGHTSMEN	JOHN STREET NORTH CLIFF 6053 www.architect.co.za

QUESTION 18: CALCULATIONS
(Show all calculations)

Perimeter:
 = Length + length + breadth + breadth
 = 14 900 + 14 900 + 14 300 + 14 300
 or
 = (14 900 + 14 300) x 2
 = 58 400 mm
 = 58,4 m

QUESTION 19: WC

Free hand
Vryhand

VRAAG 1: ANALITIES (SIVIEL)

GEGEE: Die vloerplan en elevasie van 'n huis, 'n titelpaneel en 'n tabel met vrae. Die tekening is nie volgens die getoonde skaal voorberei nie.

INSTRUKSIE: Voltooi die onderstaande tabel deur die vrae, wat na die bystaande tekening en titelpaneel verwys, netjies te beantwoord.

Toon alle berekeninge waar van toepassing.

[24]

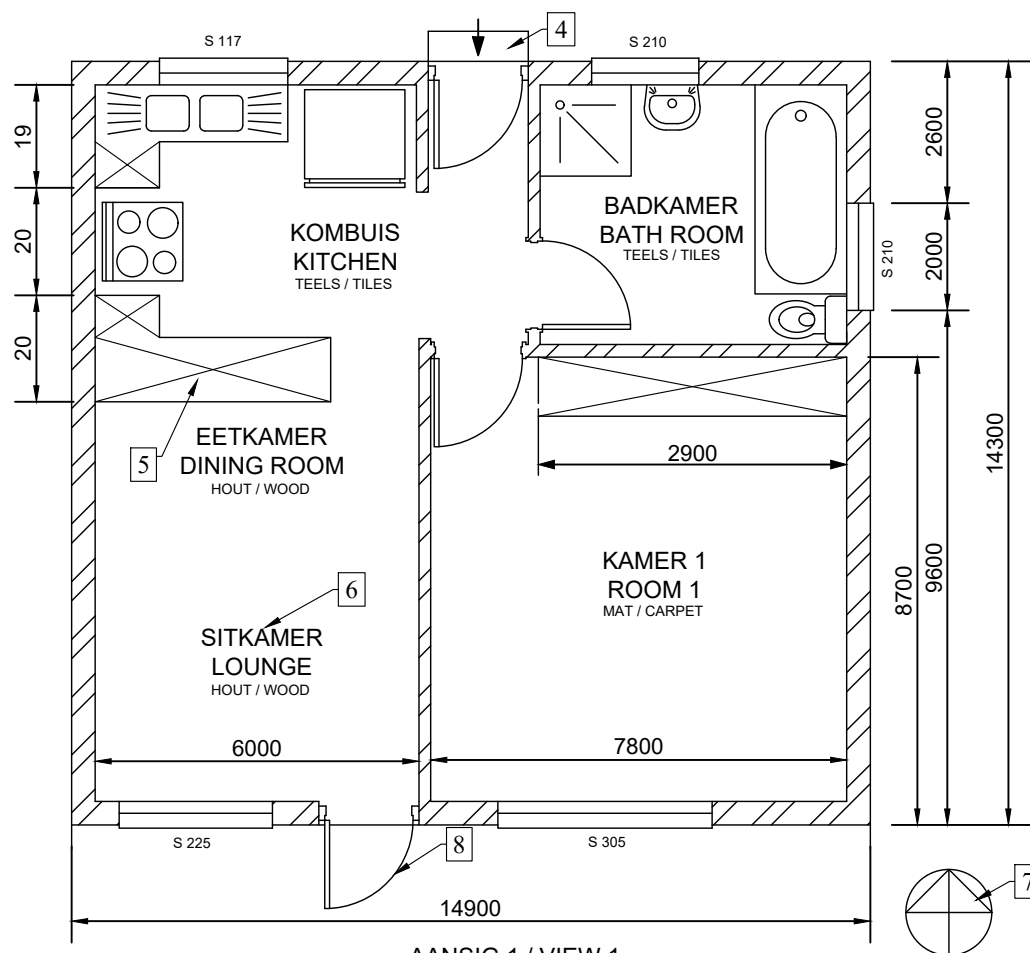
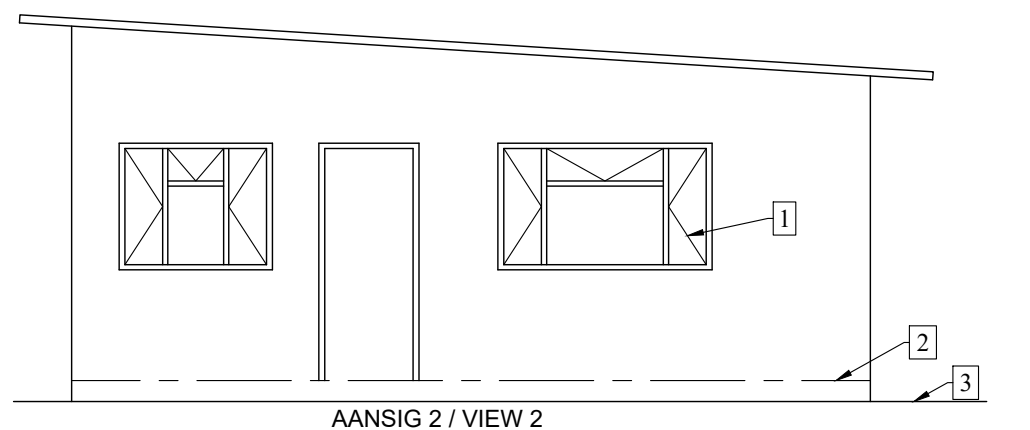

VRAE		ANTWOORDE	Punt	Behaal	Modereer
1	Hoeveel handtekeninge word benodig?	2	1		
2	Hoeveel deure word in die plan aangetoon?	4	1		
3	Hoeveel verskillende grootte vensters word op die plan getoon?	4	1		
4	Watter skaal is aangedui op die tekening?	Skaal 1:100	1		
5	Hoeveel verskillende vloerafwerkings is daar?	3	1		
6	Wat word deur nommer 1 aangetoon?	Vensteropening rigting	1		
7	Wat word deur nommer 2 aangetoon?	FVV	1		
8	Wat word deur nommer 3 aangetoon?	NGL	1		
9	Wat word deur nommer 4 aangetoon?	Trap	1		
10	Wat is die afkorting vir die eienskap wat 5 genoemmer is?	BIC	1		
11	Wat word deur nommer 6 aangetoon?	Kamer aanwysings	1		
12	Wat toon die simbool wat deur nommer 7 aangetoon is?	Rigting Noord	1		
13	Wat word deur nommer 8 aangetoon?	Swaai van die deur	1		
14	Wat sal AANSIG 1 genoem word?	Plan (Vloerplan)	1		
15	Wat sal AANSIG 2 genoem word?	Suidaansig	1		
16	In watter SI eenheid word die afmetings gegee?	Millimeters	1		
17	Watter tipe steen is gebruik om die buitewand te bou?	Pleistersteen	1		
18	In die gegewe spasie, bepaal die omtrek van die woning in meter.	95.2m	3		
19	Teken in die gegewe antwoordkolom se spasie die vooraansig en bo-aansig van 'n spoelkloset (SK), in netjiese vryhand, volgens die SANS 10143.		($\frac{8}{2}$) = 4		
TOTAAL			24		

TEKENING INLIGTING	
Nota: Kontrakteurs moet alle afmetings en hoogtes op die terrein bevestig voor daar met die werk begin word. Argitek te moet onmiddellik van enige afwykings in kennis gestel word.	GEDRUK DEUR: PERSKOR DATUM: 9/9/2015
ARGITEK HANDTEKENING:	GEKONTROLEER DEUR: RAE DATUM: 14/10/2015
KLIËNT HANDTEKENING:	GOEDGEKEUR DEUR: ERICK DATUM: 7/11/2015
	SKAAL: 1:100

Titel: VLOERPLAN - GOUE JARE AFTREEOORD	Projek: VOORGESTELDE NUWE BEHUISINGSEENHEID BY AFTREE OORD ERF 3, RENOSTERWEG
LêERNAAM: HG-03-2016	
Perfect Architect AND DRAUGHTSMEN	JOHN STREET NORTH CLIFF 6053 www.architect.co.za

VRAAG 18: BEREKENINGS
Toon alle berekenings:
Perimeter: = Length + length + breadth + breadth = 14 900 + 14 900 + 14 300 + 14 300 = (14 900 + 14 300) x 2 = 58 400 mm = 58,4 m

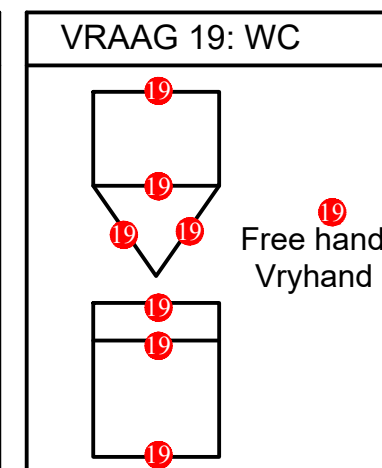

QUESTION 2 (SOLID GEOMETRY)

GIVEN: The front view of a right regular hexagonal prism indicating a hole in the form of a right square pyramid in first angle orthographic projection. The auxiliary view, the starting position S and the cutting plane AA.

INSTRUCTIONS: Draw, to scale 1:1, the following views of the right solid.

- The given front view (see starting position S)
- The top view
- A sectional left view (no hidden detail is required)
- Show the true shape of the sectioned area.

Show ALL construction lines and hidden detail on all views unless stated different.

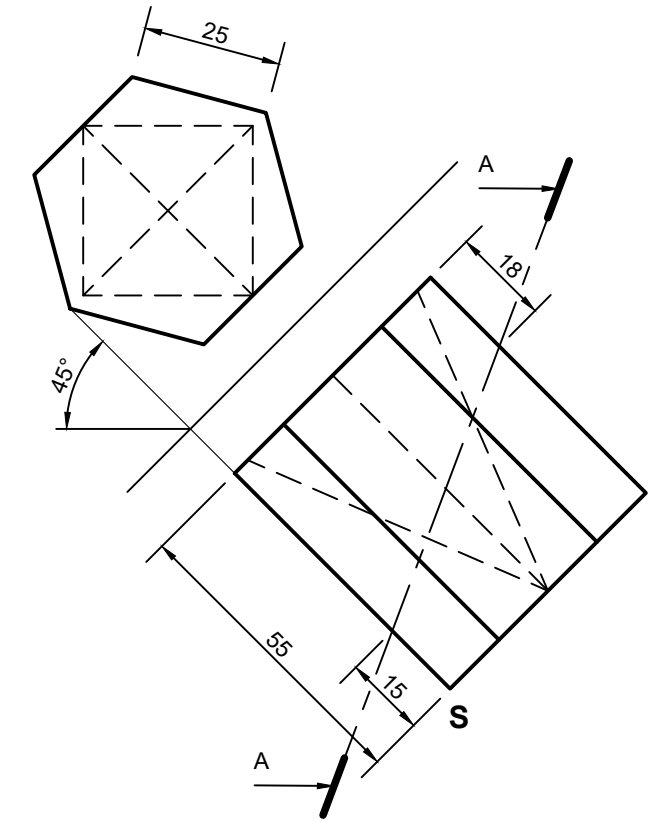
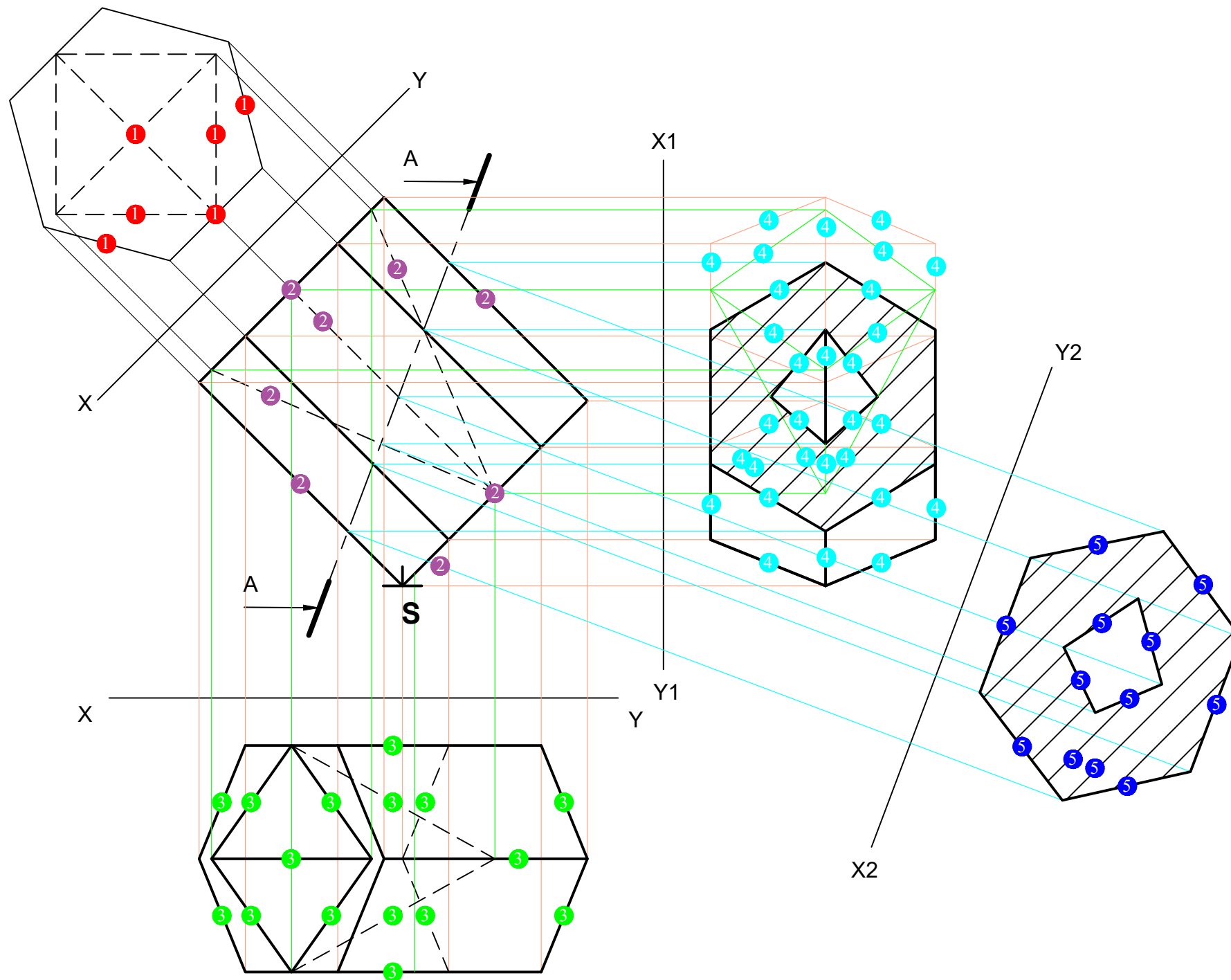

ASSESSERINGSKRITERIA ASSESSMENT CRITERIA		
Mark Punt	Obtained Behaal	Moderated Modereer
1 Auxiliary view / Hulpaansig (6/2 = 3)		
2 Front view / Vooraansig (8/2 = 4)		
3 Top view / Bo-aansig (16/2 = 8)		
4 Left view / Linkeraansig (30/2 = 15)		
5 True shape / Ware vorm (12/2 = 6)		
Total / Totaal	/36	

VRAAG 2 (VASTE LIGGAME)

GEGEE: Die vooraansig van 'n regte reëlmatige seskant met 'n gat in die vorm van 'n regte vierkantige piramide in eerstehoekse ortografiese projeksie. Die hulpaansig, die beginposisie S en die snyvlak AA.

INSTRUKSIES: Teken, volgens skaal 1:1, die volgende aansigte van die vaste liggaam.

- Die gegewe vooraansig (sien beginposisie S).
- Die bo-aansig
- Die deursnee-linkeraansig (geen verborge besonderhede word verlang)
- Toon die ware vorm van die snit.

Toon ALLE die konstruksielyste en verborge besonderhede op alle aansigte tensy anders vermeld.

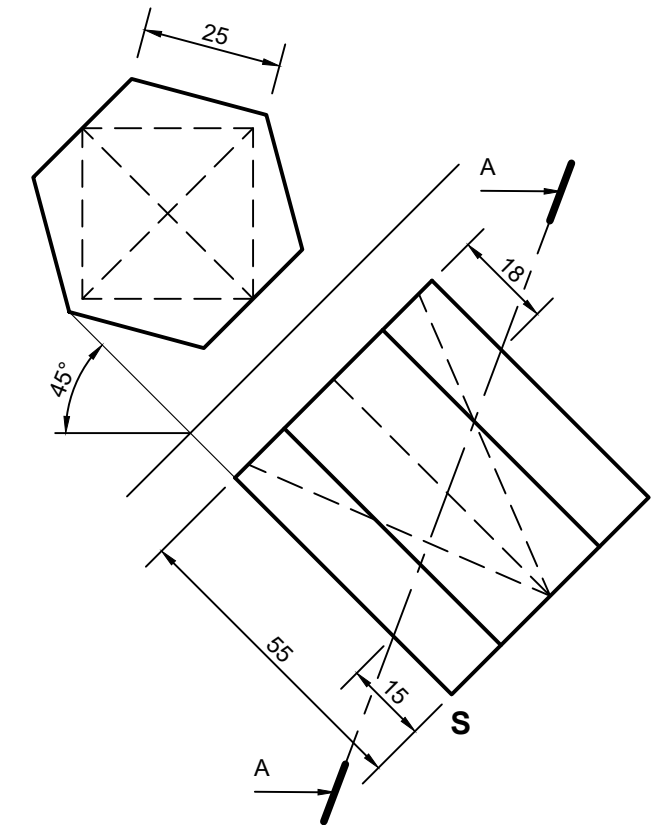
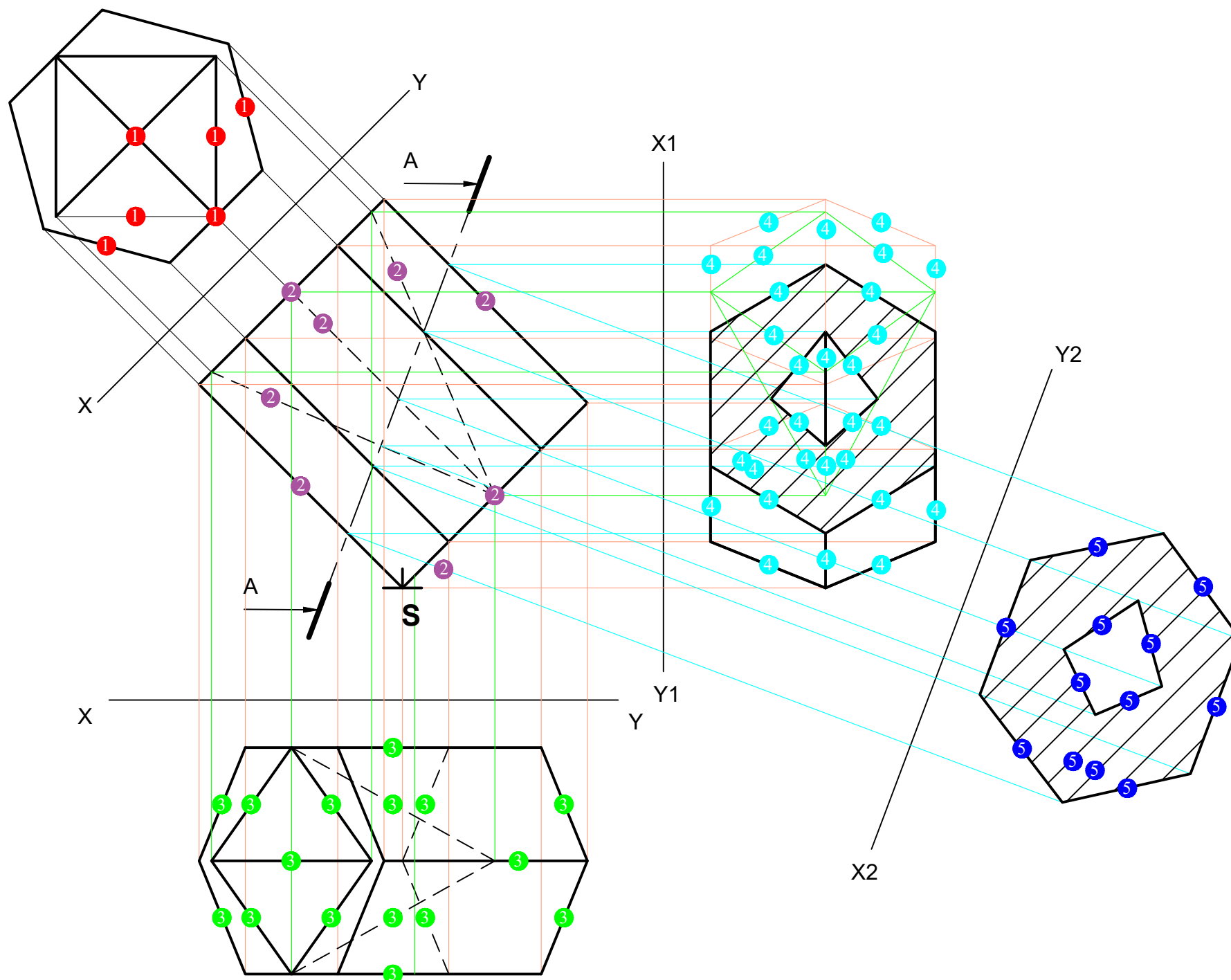

ASSESSERINGSKRITERIA ASSESSMENT CRITERIA		
Mark Punt	Obtained Behaal	Moderated Modereer
1 Auxiliary view / Hulpaansig (6/2 = 3)		
2 Front view / Vooraansig (8/2 = 4)		
3 Top view / Bo-aansig (16/2 = 8)		
4 Left view / Linkeraansig (30/2 = 15)		
5 True shape / Ware vorm (12/2 = 6)		
Total / Totaal	/36	

QUESTION 3 (PERSPECTIVE)

Two views and the information needed to draw a two-point perspective drawing is shown on the diagram sheet 3. The top view is drawn in position for completion of the perspective drawing.

Abbreviations used on the drawing are as follow:

- PP - Picture Plane
- HL - Horizon Line
- GL - Ground Line
- SP - Station Point

Determine and label the vanishing points and complete a two-point perspective drawing.

Show all construction lines.

No hidden detail is required.

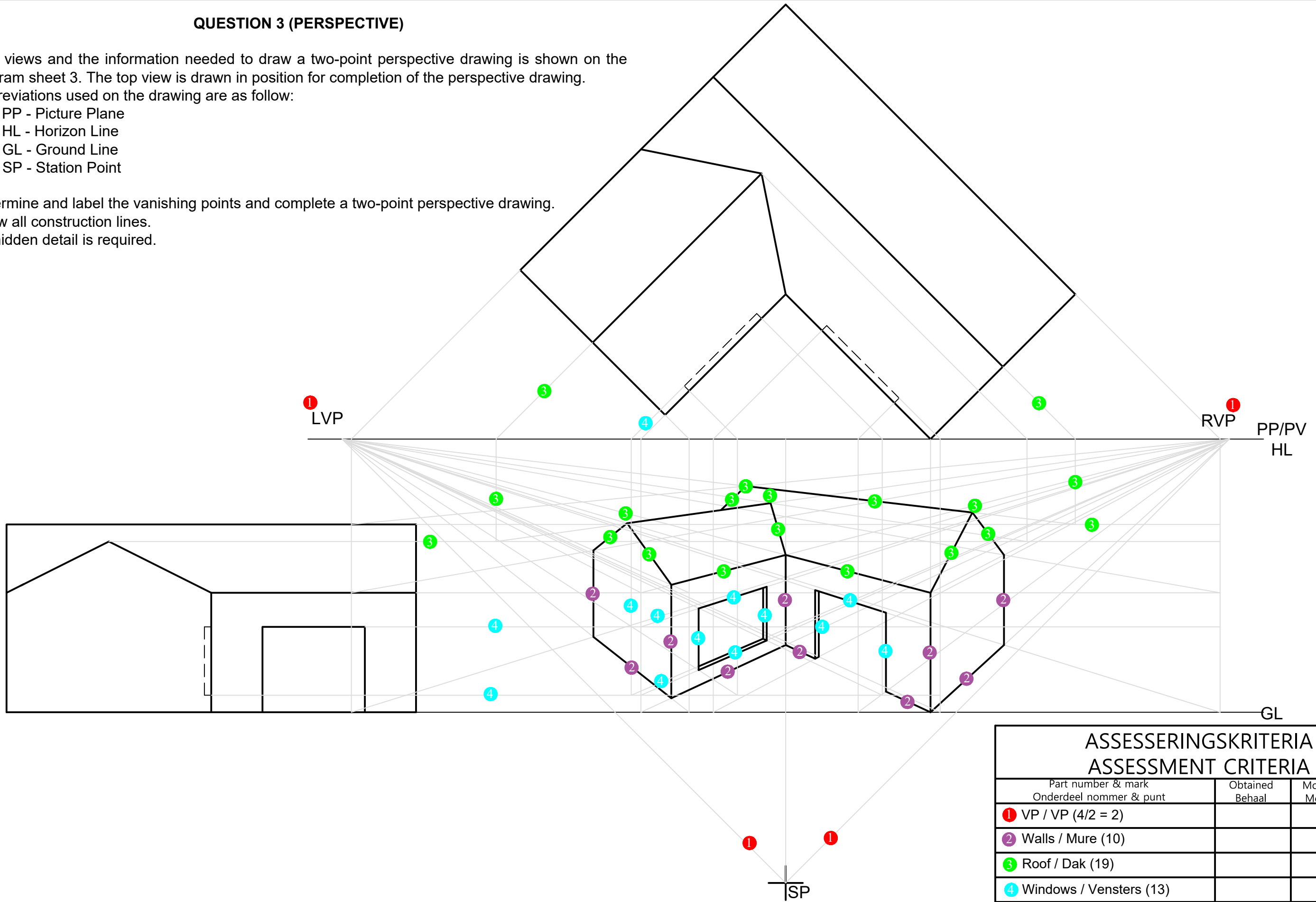

ASSESSERINGSKRITERIA ASSESSMENT CRITERIA		
Part number & mark Onderdeel nummer & punt	Obtained Behaal	Moderated Modereer
1 VP / VP (4/2 = 2)		
2 Walls / Mure (10)		
3 Roof / Dak (19)		
4 Windows / Vensters (13)		
Total / Totaal	/44	

VRAAG 3 (PERSPEKTIEF)

Twee aansigte met die nodige inligting benodig om 'n tweepunt-perspektieftekening te teken word op diagramvel 3 getoon. Die bo-aansig is in posisie geteken vir die voltooiing van die perspektief tekening.

Afkortings gebruik op die tekening is soos volg:

- PV - Prentvlaklyn
- HL - Horisonlyn
- GL - Grondlyn
- SP - Staanpunt

Bepaal en benoem die verdwynpunte en voltooi die tweepunt-perspektieftekening. Toon alle konstruksielyste.

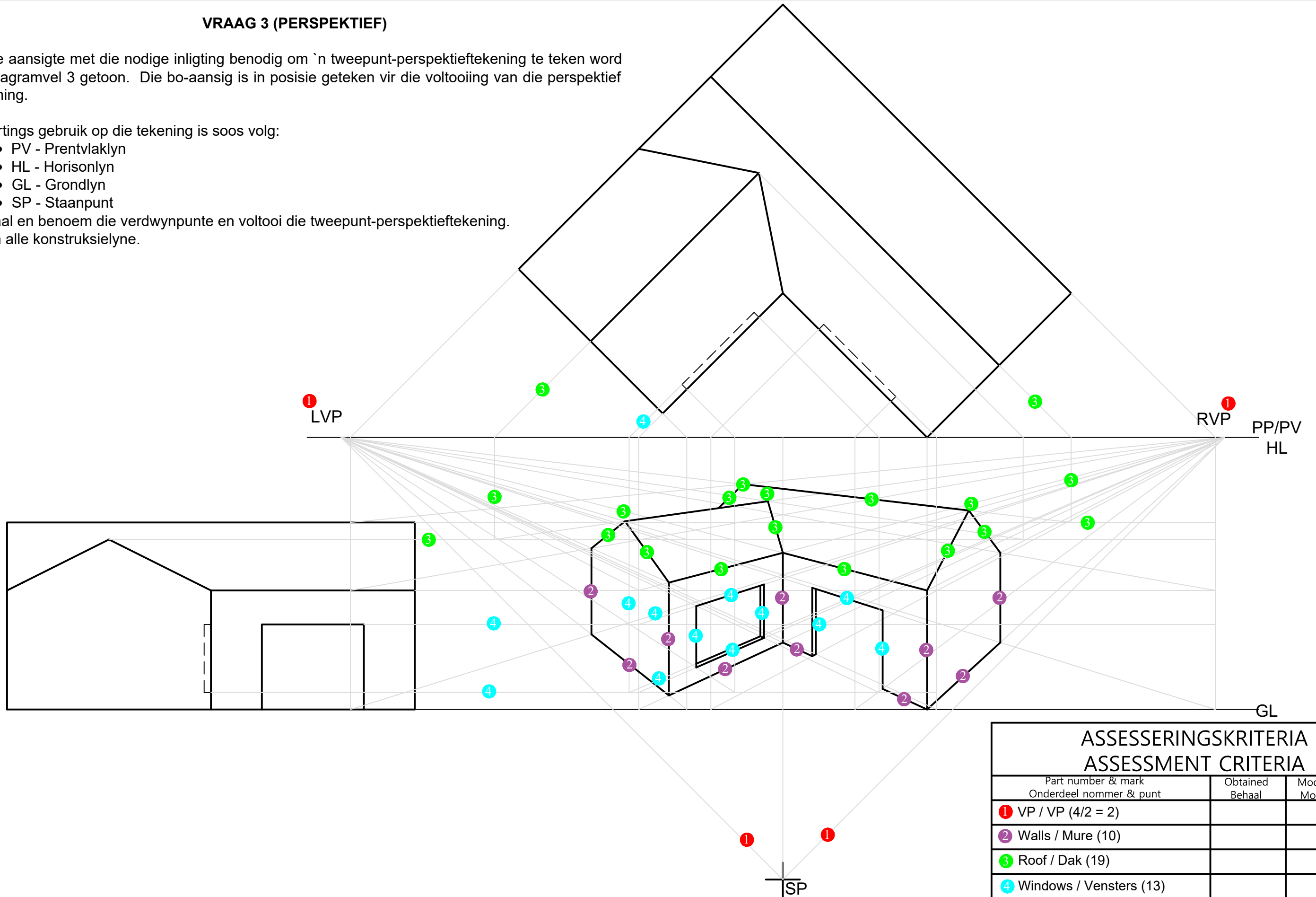

ASSESSERINGSKRITERIA ASSESSMENT CRITERIA		
Part number & mark Onderdeel nommer & punt	Obtained Behaal	Moderated Modereer
1 VP / VP (4/2 = 2)		
2 Walls / Mure (10)		
3 Roof / Dak (19)		
4 Windows / Vensters (13)		
Total / Totaal	/44	

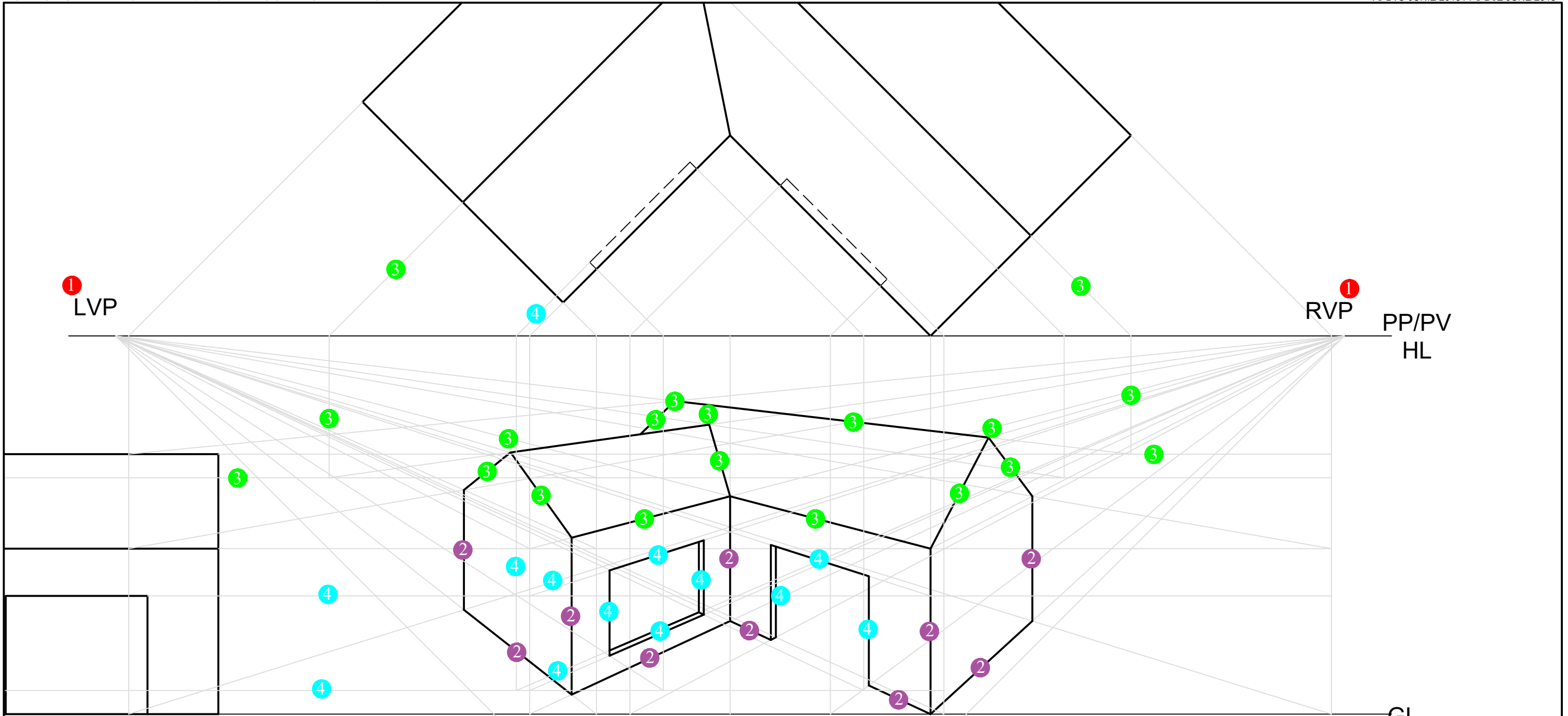

ASSESSERINGSKRITERIA ASSESSMENT CRITERIA		
Part number & mark Onderdeel nommer & punt	Obtained Behaal	Moderated Modereer
① VP / VP (4/2 = 2)		
② Walls / Mure (10)		
③ Roof / Dak (19)		
④ Windows / Vensters (13)		
Total / Totaal	/44	

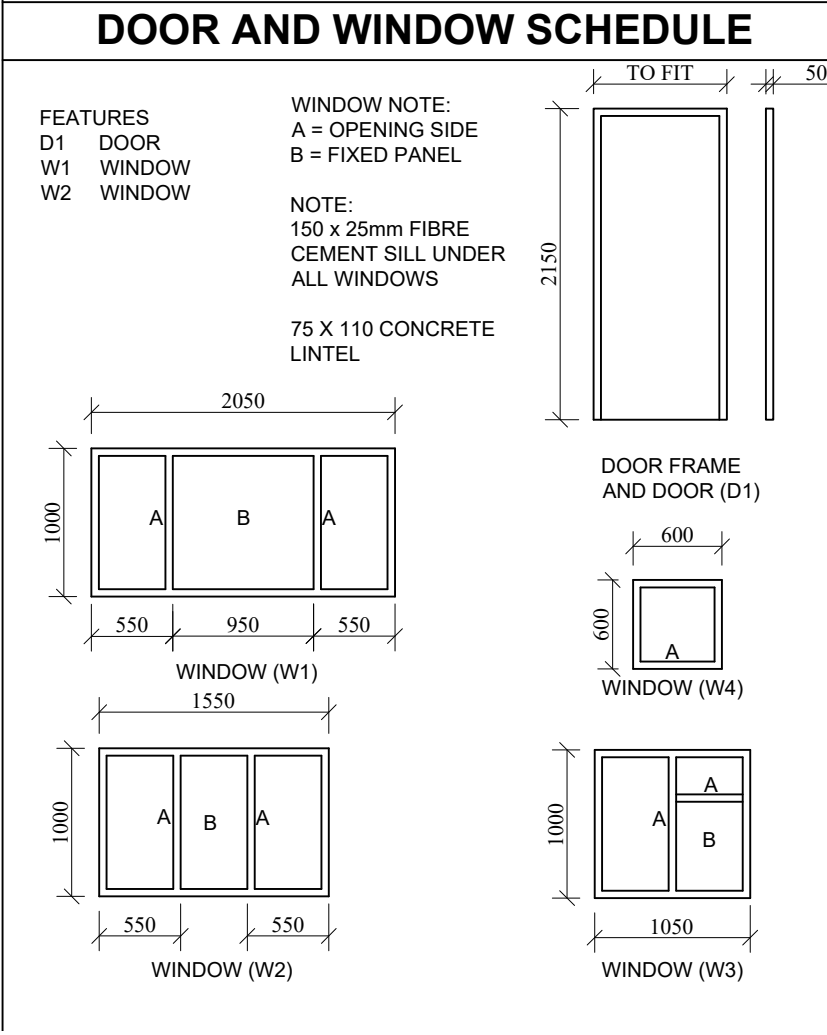
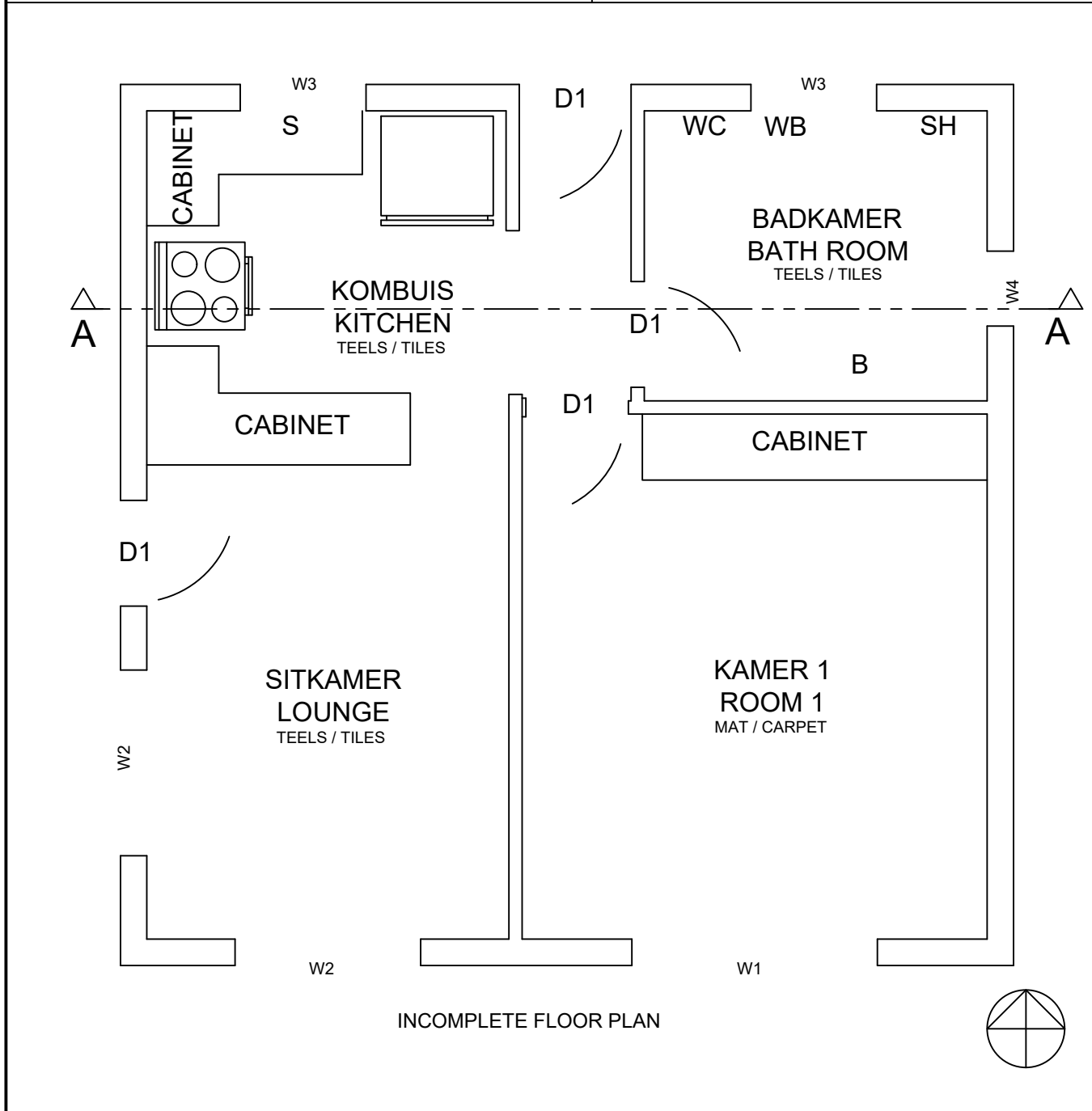
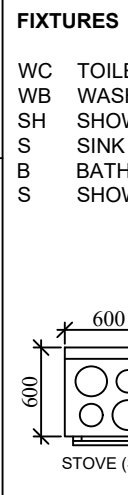
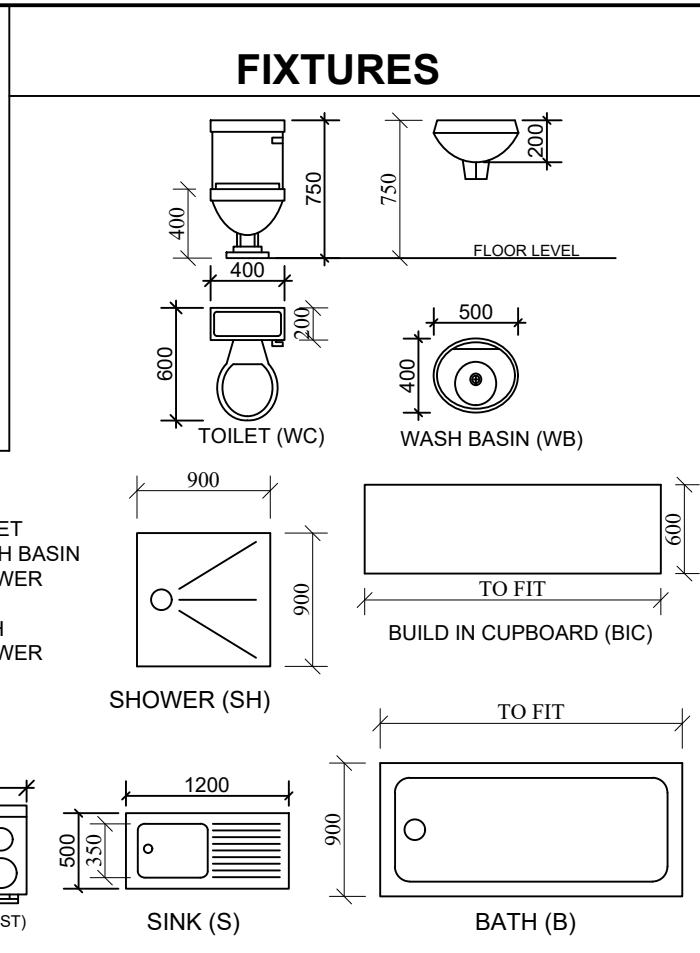
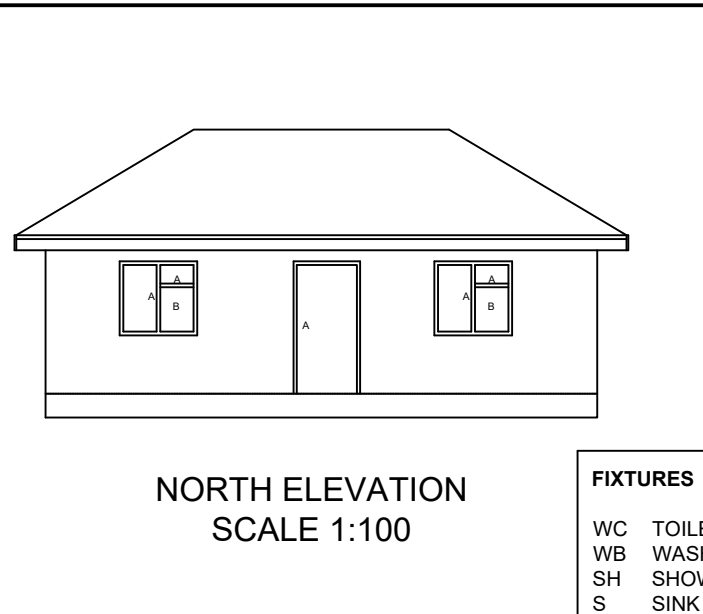
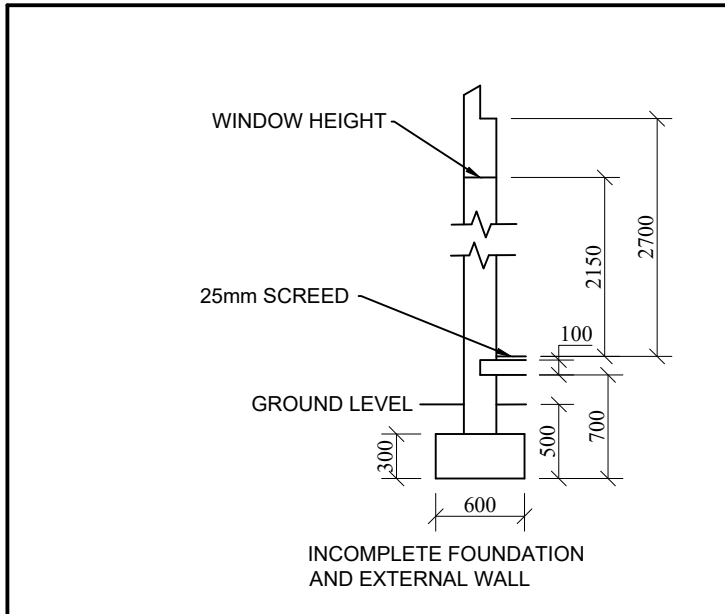

QUESTION 4 (CIVIL)

Given:

- The complete north elevation of a new cottage.
- The incomplete floor plan showing the walls, positions of the doors, windows and fixtures.
- The incomplete foundation and wall detail.
- A door and window schedule.
- A table of fixtures.
- The incomplete floor plan of the new cottage, drawn to scale 1 : 50, on diagram sheet 4B.
- The incomplete section elevation of the new cottage, drawn to scale 1 : 50, on diagram sheet 4B.
- The incomplete west elevation of the new cottage, drawn to scale 1 : 50, on diagram sheet 4B.

Instructions:
Answer the question on diagram sheet 4B. ALL drawings must comply with the **guidelines** and **graphical symbols** contained in the SANS 10143.
Use the given incomplete floor plan, draw to scale 1 : 50, in first angle orthographic projection, the following views of the new cottage:

4.1 THE COMPLETE FLOOR PLAN

Add the following features to the drawing:

- ALL doors and windows.
- ALL fixtures placed as indicated by abbreviations.
- ALL hatching detail.
- Indicate the room designation and floor finishing for each room.
- Name this view and indicate the scale.

4.2 Using the given incomplete foundation, draw, to scale 1 : 50, a **DETAILED SECTION** on cutting plane A-A.

Show the following features on the drawing:

- The complete door and window detail. The door entering towards the kitchen extend to ceiling height.
- ALL hatching detail. ONLY the substructure hatching may be drawn in neat freehand.
- ALL fixtures as indicated by abbreviations.
- Name this view and indicate the scale.

4.3 The WEST ELEVATION

Show the following features to the drawing:

- The door and window features.
- Name this view and indicate the scale.

Label the following:
Using the correct abbreviations, label the following features in the sectional elevation and west elevation:

- Natural ground level
- Damp prove course.

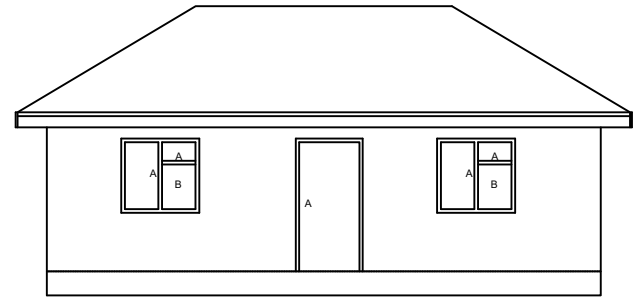
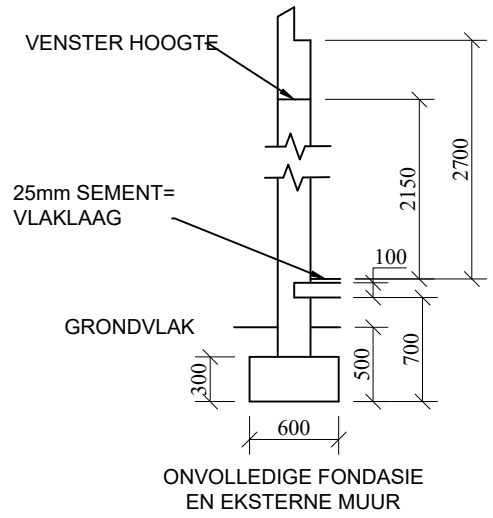

NOORD-AANSIG
SKAAL 1:100

TOEBEHORE

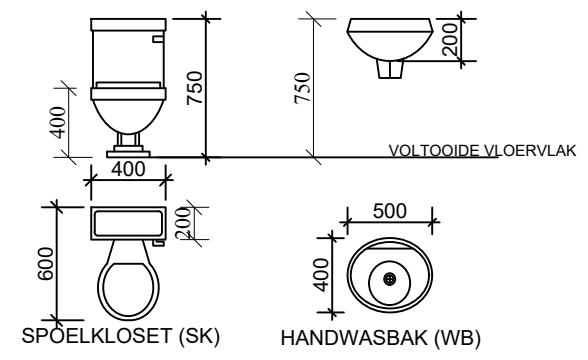

TOEBEHORE

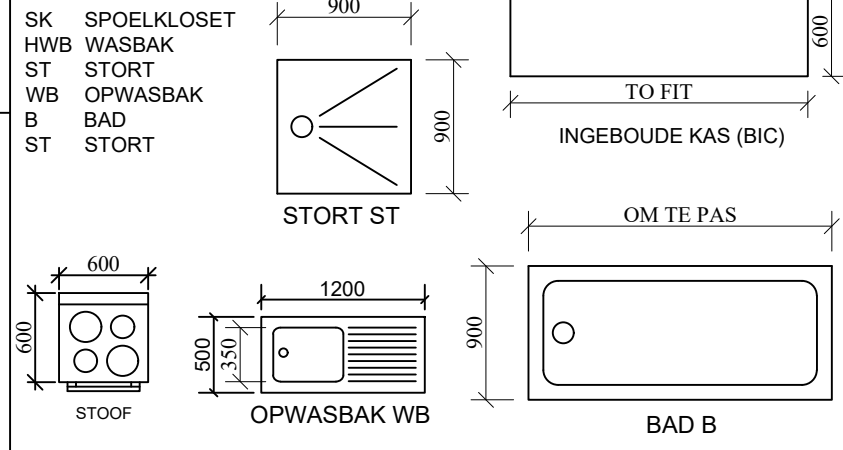

DEUR EN VENSTERSKEDULE

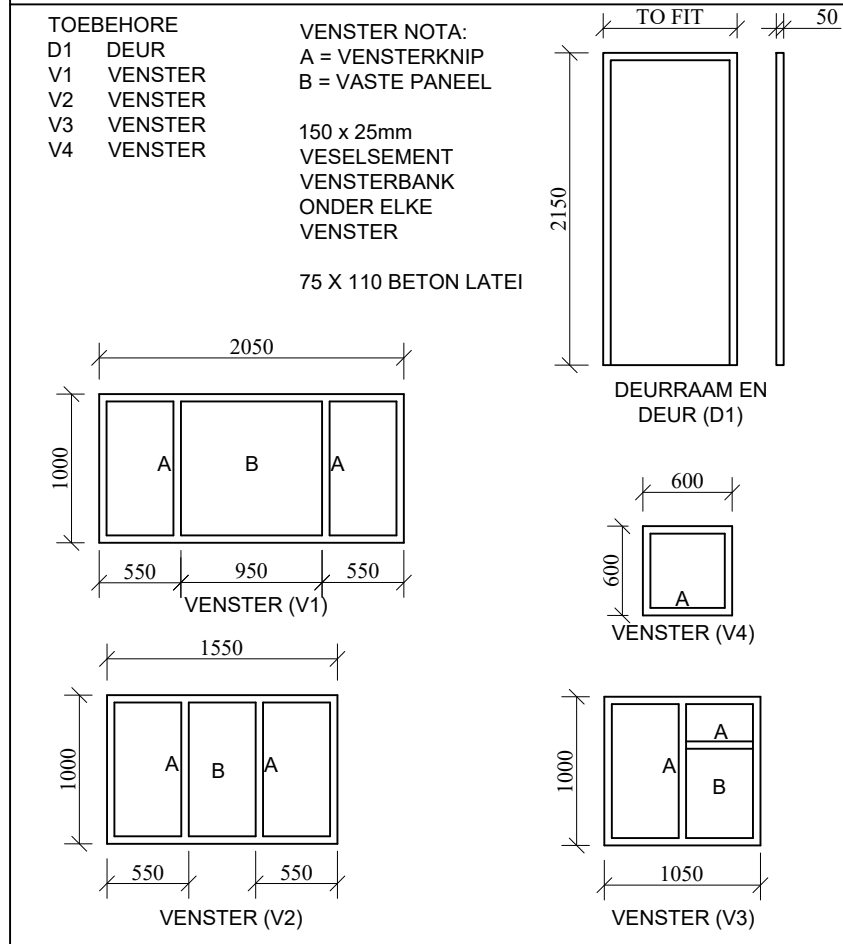

VRAAG 4 (SIVIEL)

Gegee:

- 'n Volledige noordaansig van 'n nuwe huis.
- 'n Onvolledige vloerplan wat die mure, posisie van die deure, vensters en toebehore toon.
- 'n Onvolledige fondasie- en muurbesonderhede.
- 'n Deur en vensterskedule.
- 'n Tabel met toebehore.
- 'n Onvolledige vloerplan van die nuwe huis, geteken op 'n skaal van 1:50 op diagramvel 4B.
- 'n Onvolledige snitaansig van die nuwe huis geteken op 'n skaal van 1:50 op diagramvel 4B.
- 'n Onvolledige wesaansig van die nuwe huis, geteken op 'n skaal van 1:50 op diagramvel 4B.

Instruksies:

Beantwoord hierdie vraag op diagramvel 4B. ALLE tekeninge moet voldoen aan die riglyne en grafiese simbole vervat aan die SANS 10143.

Gebruik die onvolledige vloerplan, teken volgens skaal 1:50 en in eerstehoekse ortografiese projeksie, die volgende aansigte van die nuwe huis:

4.1 DIE VOLLEDIGE VLOERPLAN

Voeg die volgende kenmerke by die tekening:

- ALLE deure en vensters.
- Alle toebehore moet geplaas word soos deur die afkortingslys aangedui is.
- ALLE arseringsbesonderhede.
- Benoem die kamer- en vloerafwerking van elke vertrek.
- Benoem die aansig en dui die skaal aan.

4.2 Gebruik die onvolledige fondasie en breeklyn op bladsy 6 en teken, volgens skaal 1:50, 'n **GEDETAILLEERDE SNIT** op snyvlak AA.

Toon die volgende kenmerke op die tekening:

- Die volledige deur en venster besonderhede. Die deur na die kombuis verleng tot by plafonhoogte.
- ALLE arseringsbesonderhede. Alleenlik die substruktuur se arsering mag vryhand gedoen word.
- ALLE toebehore soos deur die afkortingslys aangedui.
- Benoem die aansig en dui die skaal aan.

4.3 DIE WESAANSIG

Voeg die volgende by die tekening:

- Die deur en venster
- Benoem die aansig en dui die skaal aan.

Benoem die volgende:

Gebruik die korrekte afkortings en benoem die volgende eienskappe in die snitaansig:

- Natuurlike grondvlak
- Vogweerlaag.

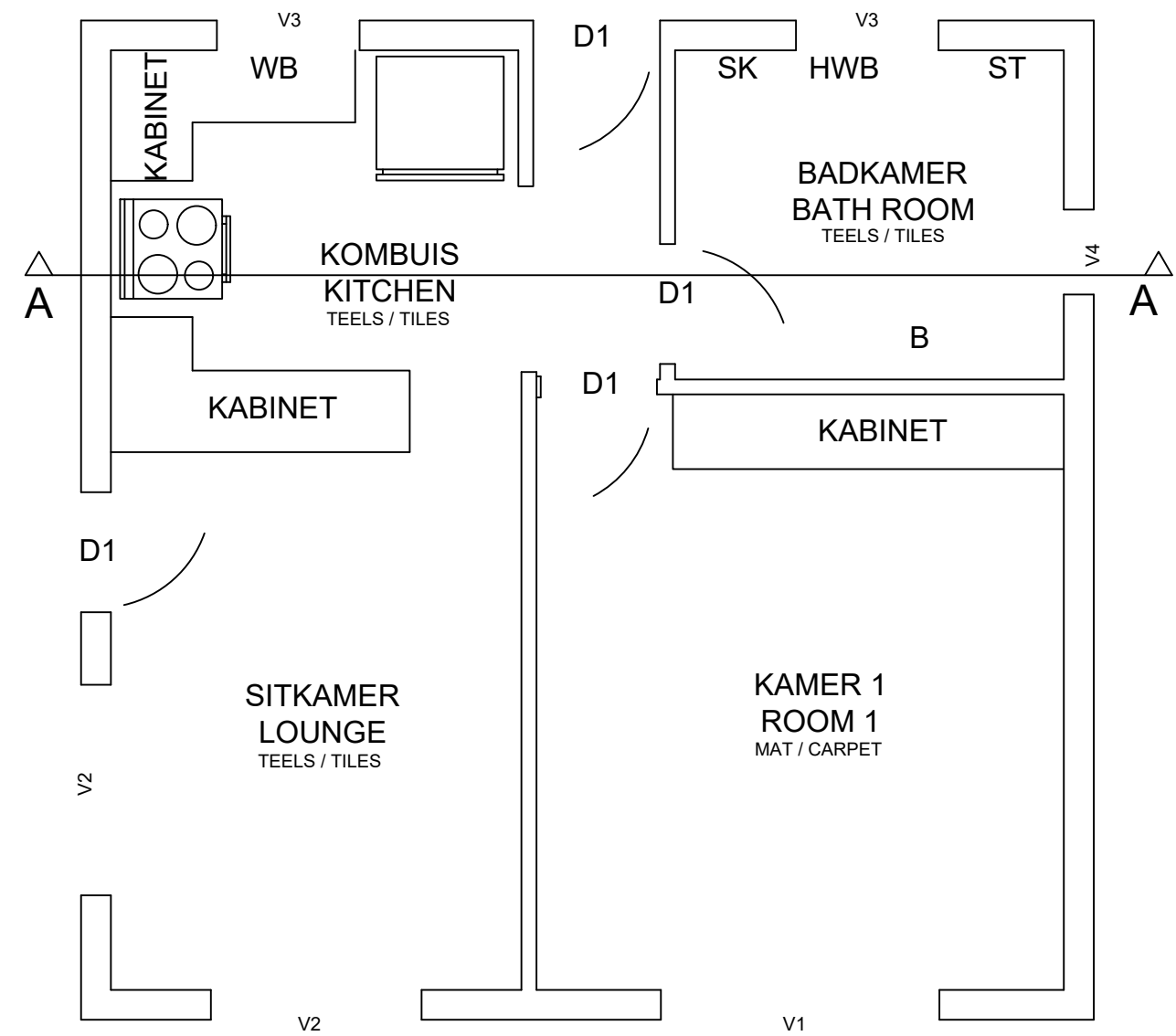

ONVOLLEDIGE VLOERPLAN

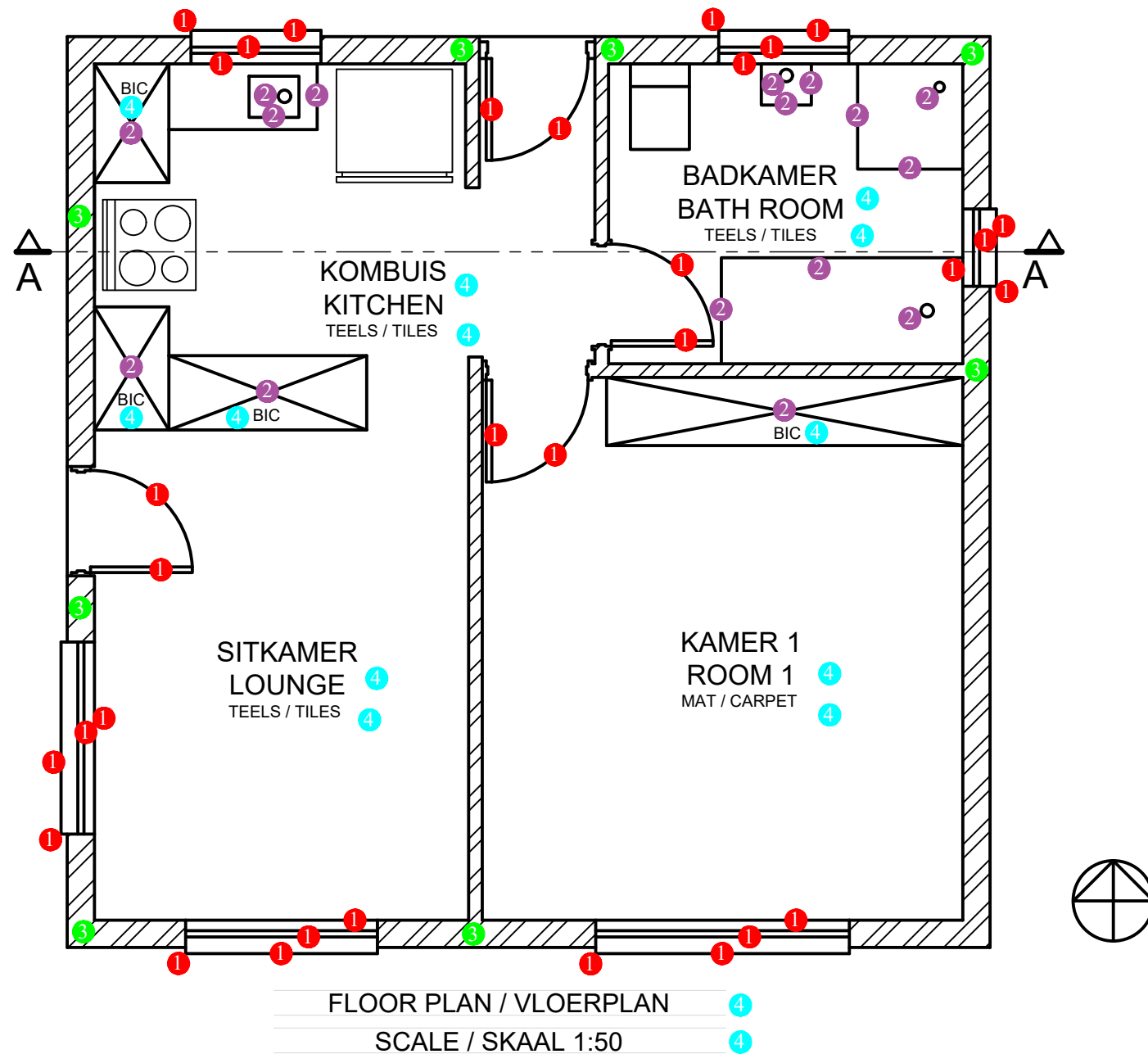
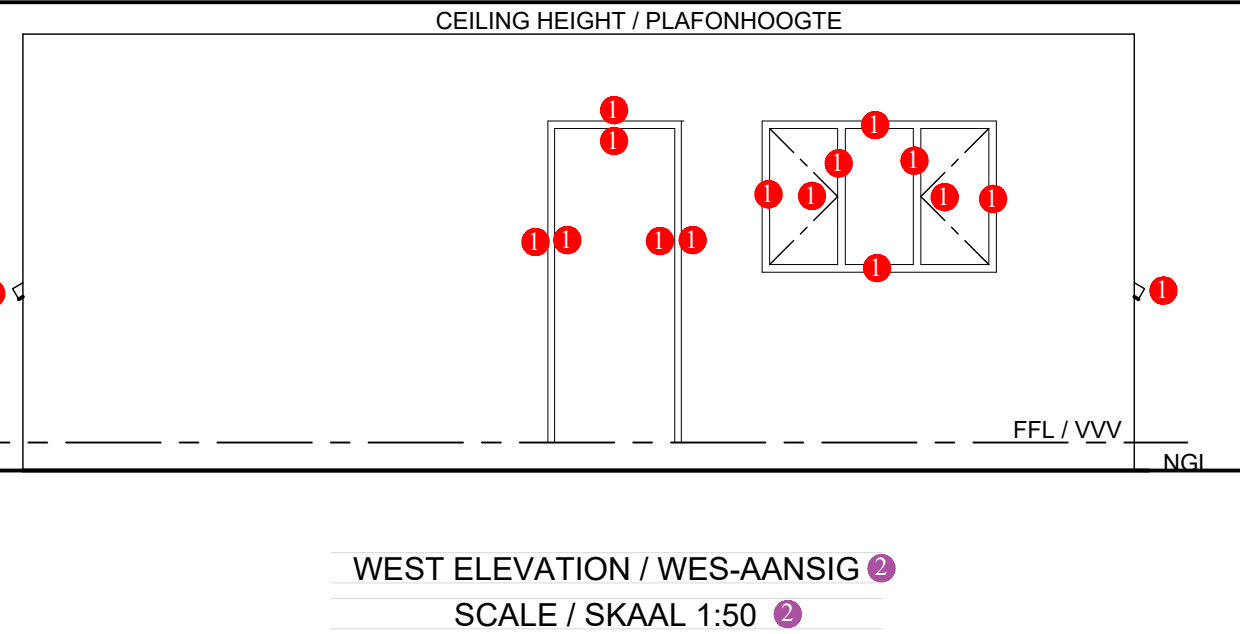
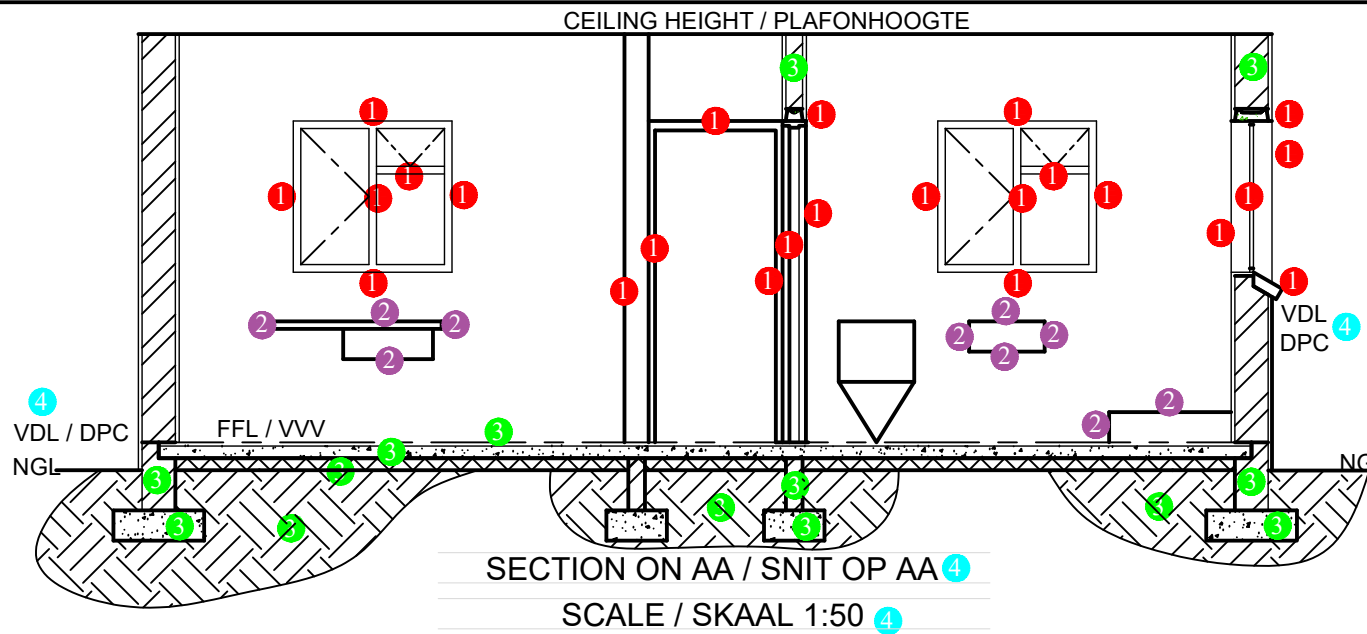

ASSESSERINGSKRITERIA ASSESSMENT CRITERIA			
FLOORPLAN / VLOERPLAN		M	M
VENSTERS + DEURE WINDOW + DOORS	32/2= 16	1	
TOEBEHORE FIXTURES	16/2= 8	2	
ARSERING HATCHING	8/2= 4	3	
BYSKRIFTE LABELS	14/2= 7	4	
Sub-Tot.	/35		
SECTION ON AA / SNIT OP AA		M	M
VENSTERS + DEURE WINDOW + DOORS	24/2= 12	1	
TOEBEHORE FIXTURES	10/2= 5	2	
ARSERING HATCHING	14/2= 7	3	
BYSKRIFTE LABELS	4/2= 2	4	
Sub-Tot.	/26		
WEST ELEVATION / WESAANSIG		M	M
VENSTERS + DEURE WINDOW + DOORS	16/2= 8	1	
BYSKRIFTE LABELS	4/2= 2	2	
Sub-Tot.	/10		
TOTAL / TOTAAL	/71		