

# EGD Grade 11

## Interpenetrations

Developed by: PC Viljoen  
Senior Educational Specialist for  
Engineering Graphics and Design

Free State Province

# Interpenetrations

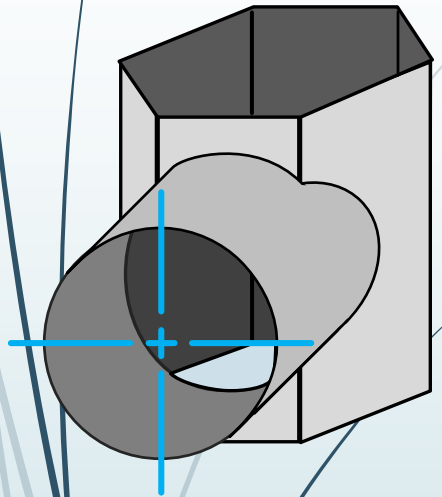

## Question 2: Interpenetration

### Given:

\* The incomplete front view and top view of an cylinder branch that has to fit around a hexagonal prism. The axes of both solid bodies lie in a common vertical plane

\* An auxiliary view of the cylinder

### Instructions:

Draw, to scale 1:1, the following:

1. The given top view
2. The complete front view clearly showing the curve of interpenetration
1. The complete left view

\* Show ALL hidden detail

\* Show ALL necessary construction.

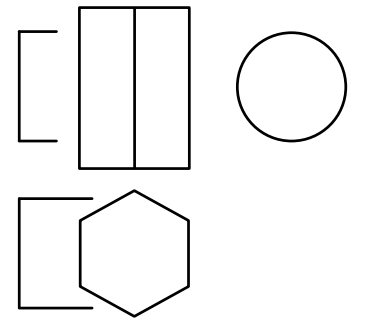

# Interpenetrations

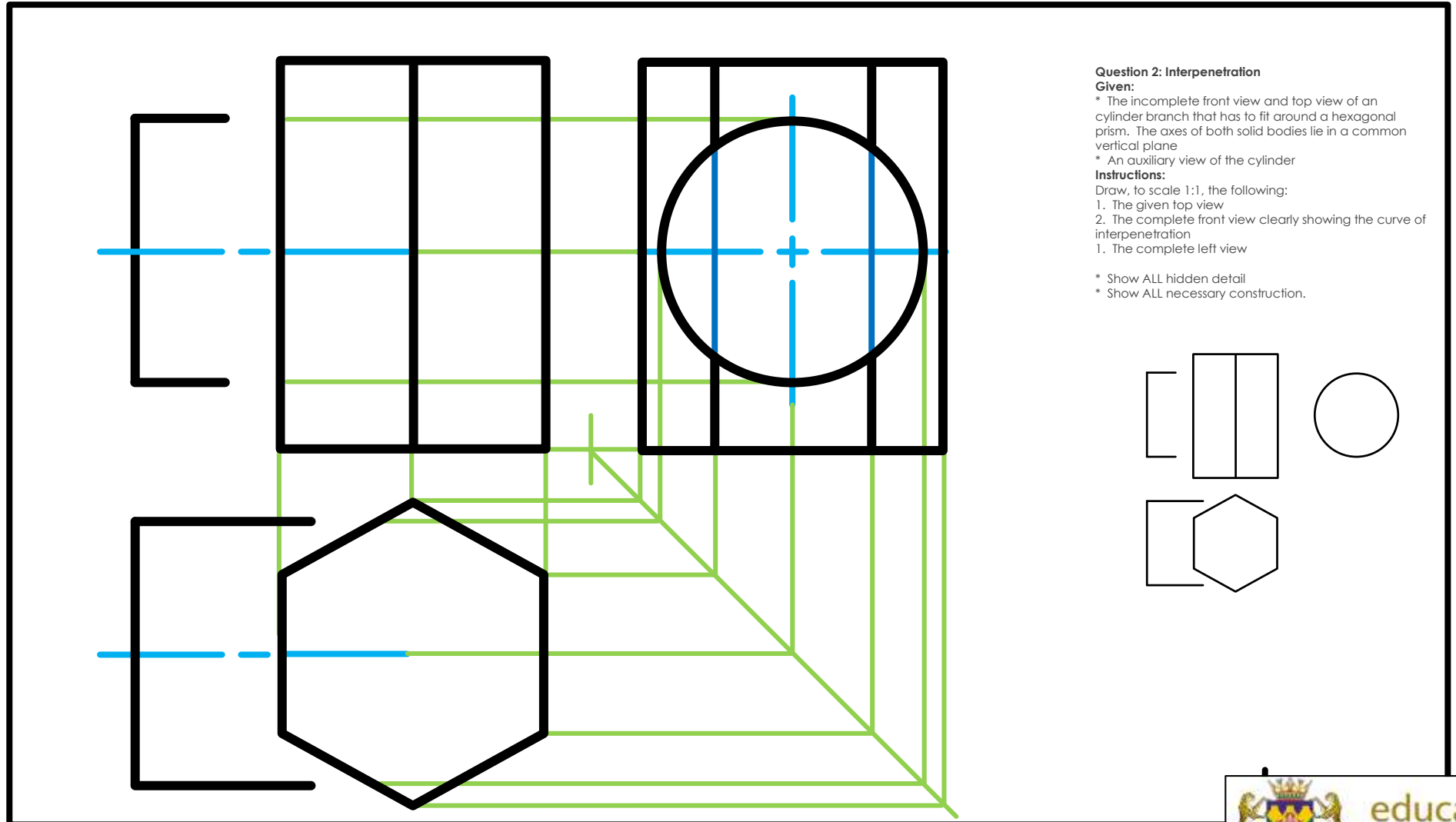
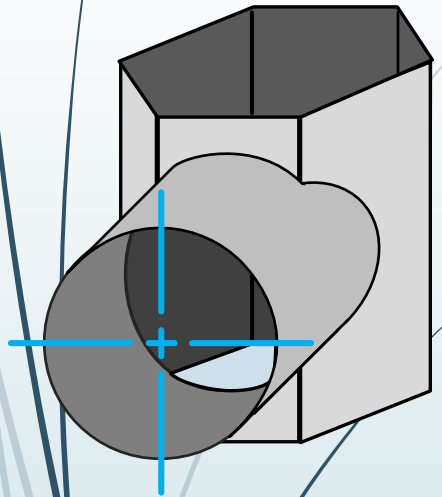

## Question 2: Interpenetration

### Given:

\* The incomplete front view and top view of an cylinder branch that has to fit around a hexagonal prism. The axes of both solid bodies lie in a common vertical plane

\* An auxiliary view of the cylinder

### Instructions:

Draw, to scale 1:1, the following:

1. The given top view
2. The complete front view clearly showing the curve of interpenetration
1. The complete left view

\* Show ALL hidden detail

\* Show ALL necessary construction.

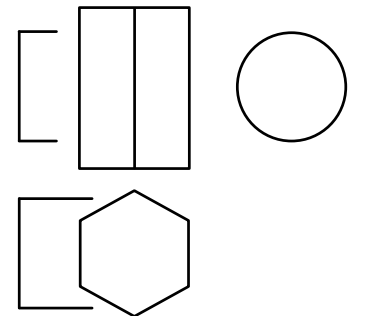

# Interpenetrations

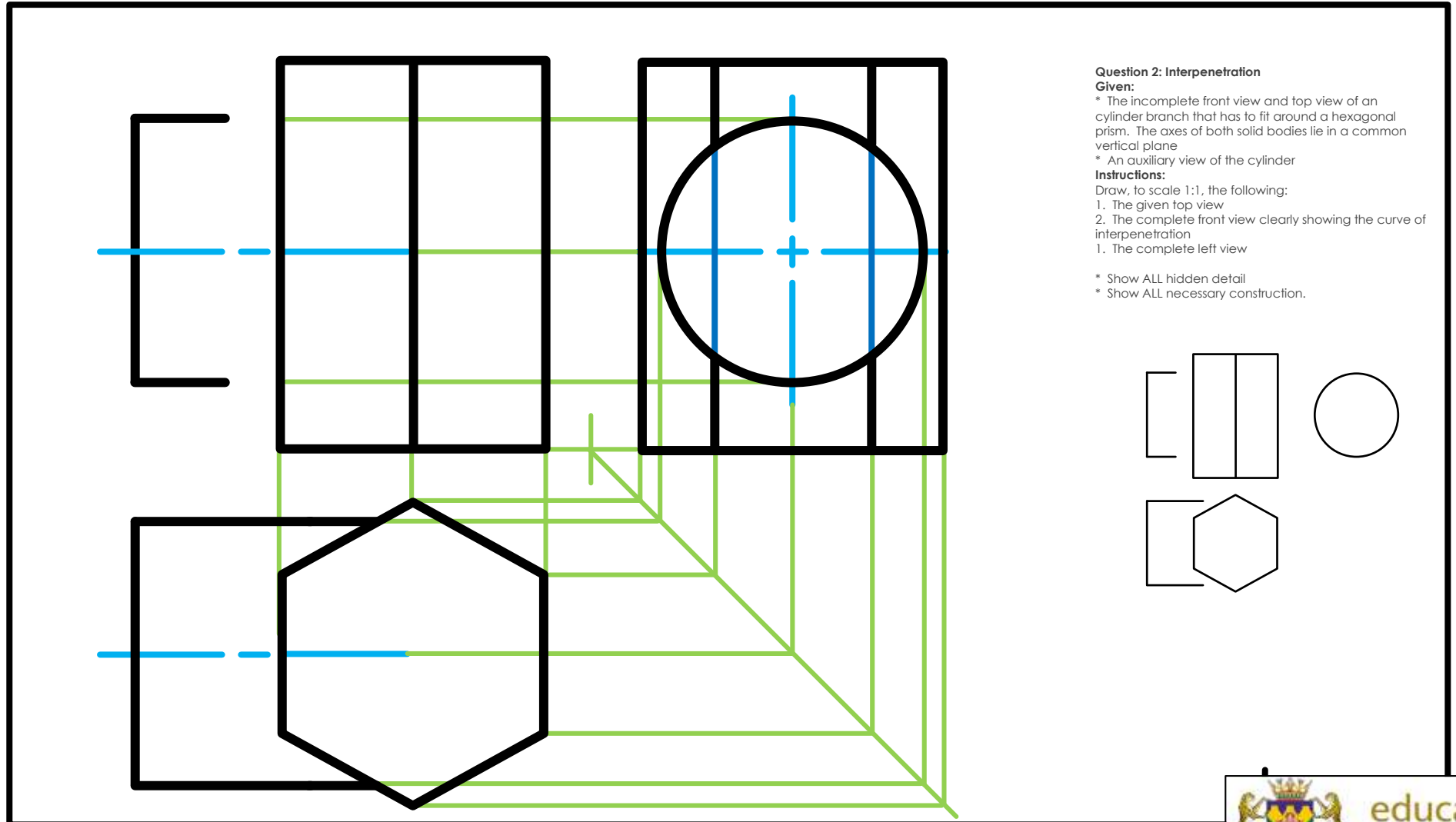
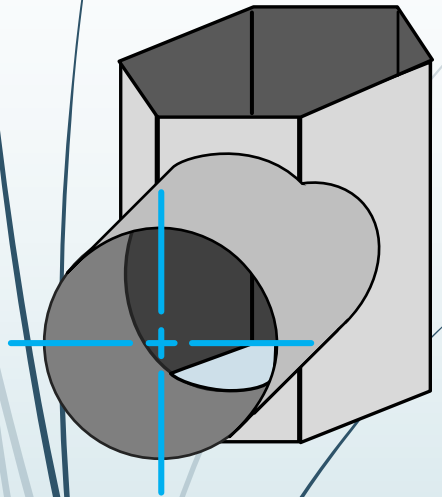

## Question 2: Interpenetration

### Given:

\* The incomplete front view and top view of an cylinder branch that has to fit around a hexagonal prism. The axes of both solid bodies lie in a common vertical plane

\* An auxiliary view of the cylinder

### Instructions:

Draw, to scale 1:1, the following:

1. The given top view
2. The complete front view clearly showing the curve of interpenetration
1. The complete left view

\* Show ALL hidden detail

\* Show ALL necessary construction.

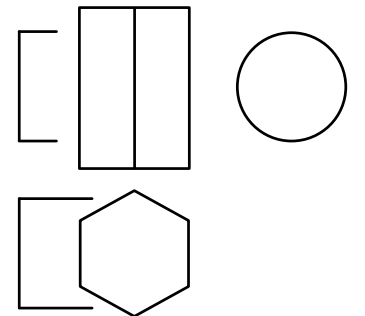

# Interpenetrations

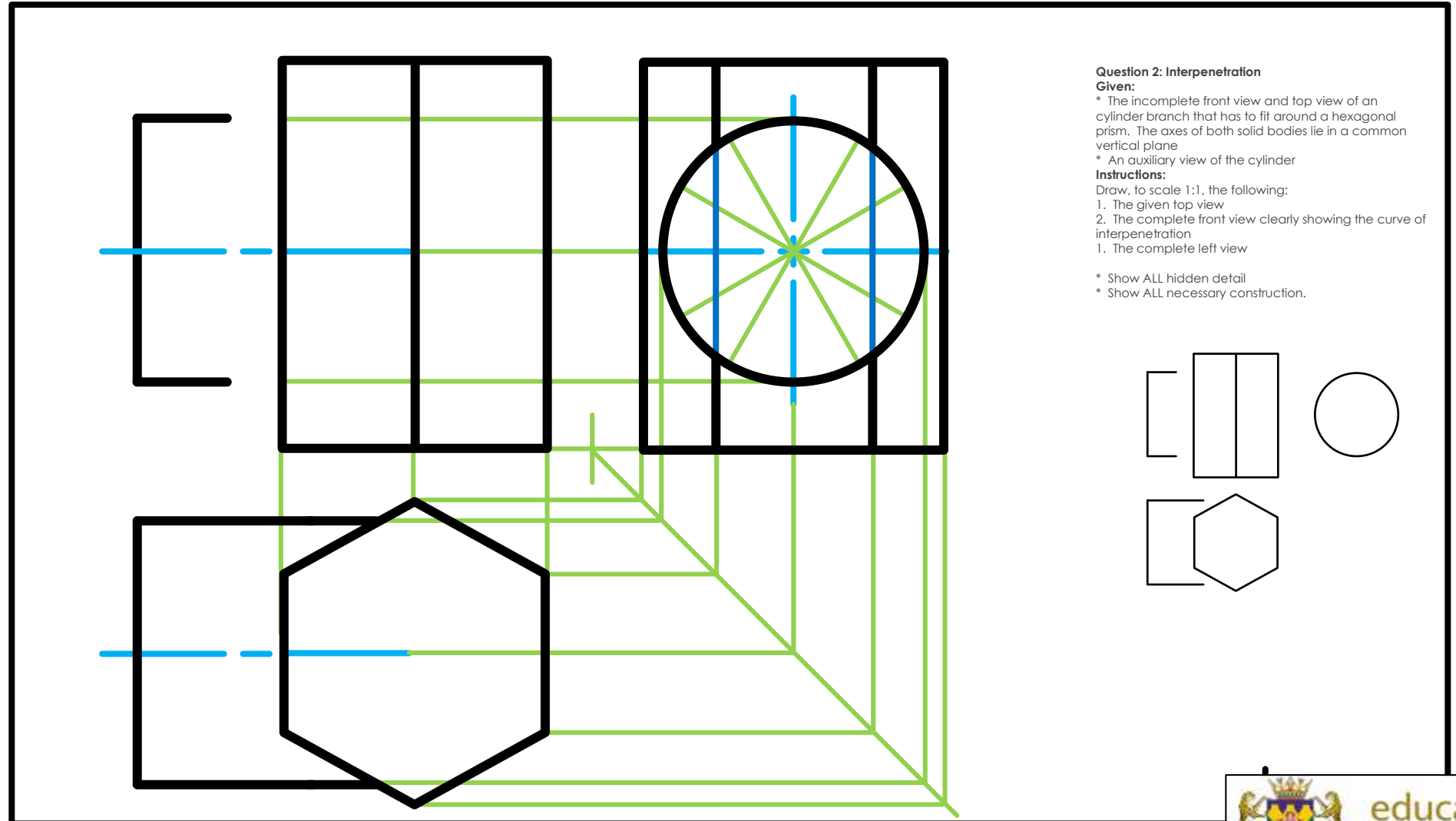
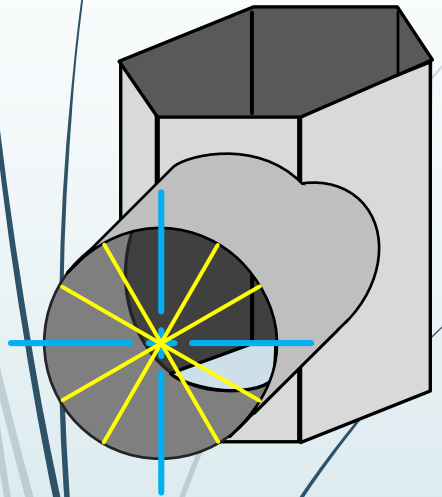

## Question 2: Interpenetration

### Given:

\* The incomplete front view and top view of an cylinder branch that has to fit around a hexagonal prism. The axes of both solid bodies lie in a common vertical plane

\* An auxiliary view of the cylinder

### Instructions:

Draw, to scale 1:1, the following:

1. The given top view
2. The complete front view clearly showing the curve of interpenetration
1. The complete left view

\* Show ALL hidden detail

\* Show ALL necessary construction.

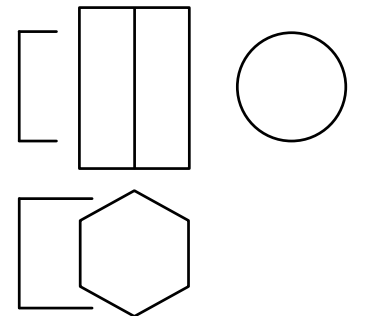

# Interpenetrations

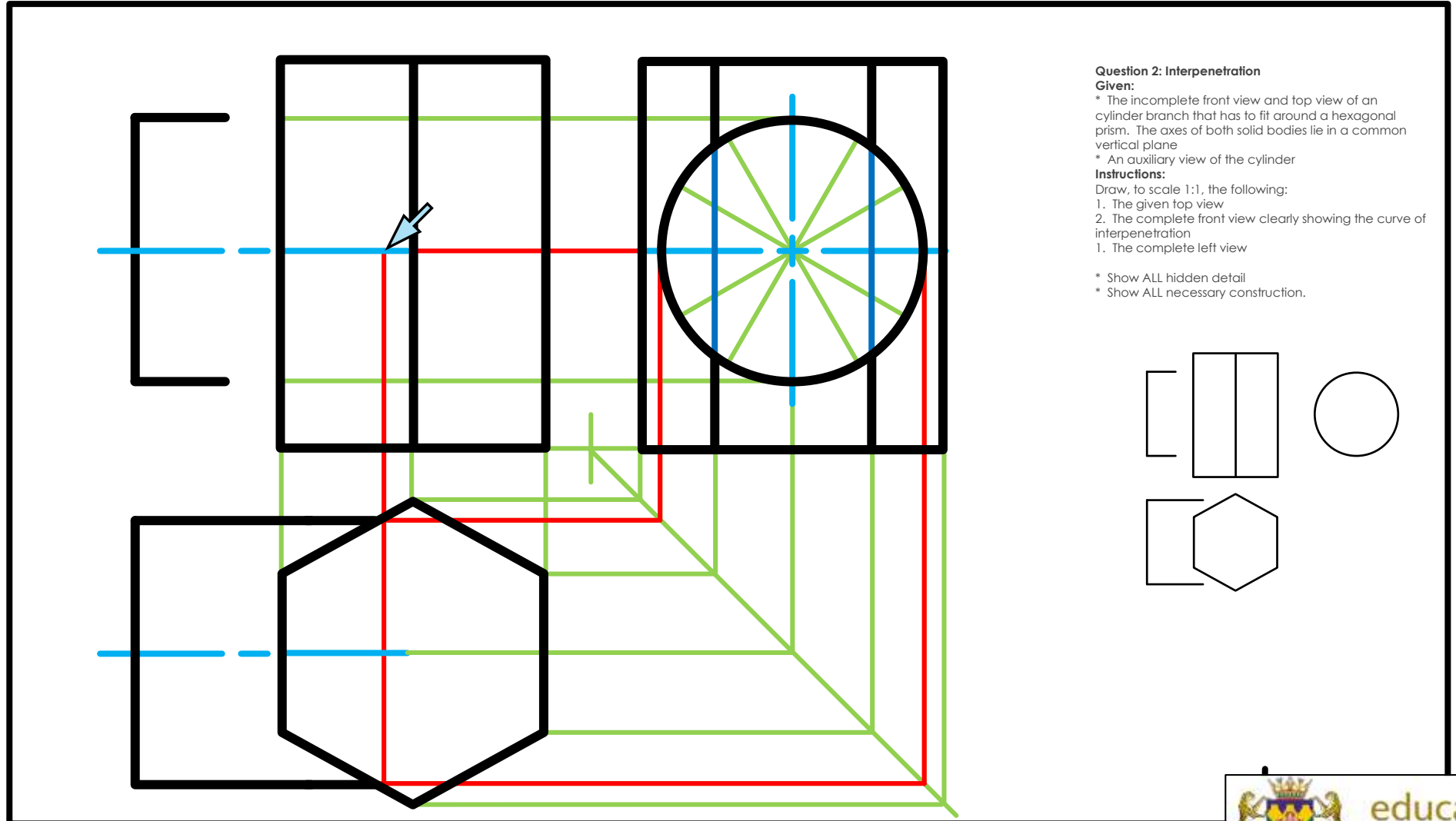
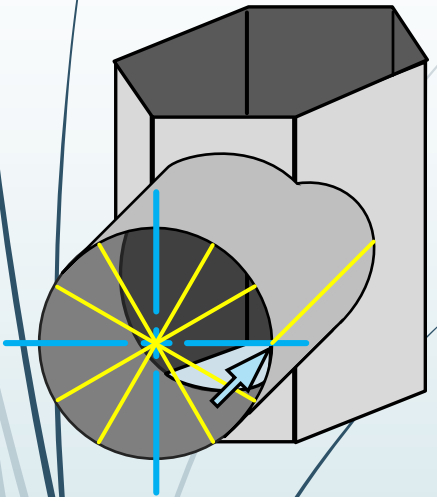

## Question 2: Interpenetration

### Given:

\* The incomplete front view and top view of an cylinder branch that has to fit around a hexagonal prism. The axes of both solid bodies lie in a common vertical plane

\* An auxiliary view of the cylinder

### Instructions:

Draw, to scale 1:1, the following:

1. The given top view
2. The complete front view clearly showing the curve of interpenetration
1. The complete left view

\* Show ALL hidden detail

\* Show ALL necessary construction.

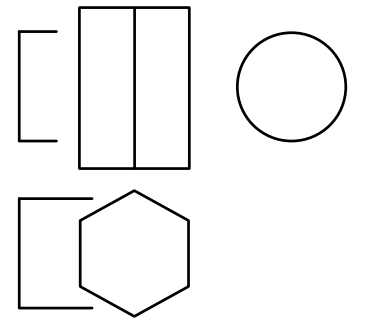

# Interpenetrations

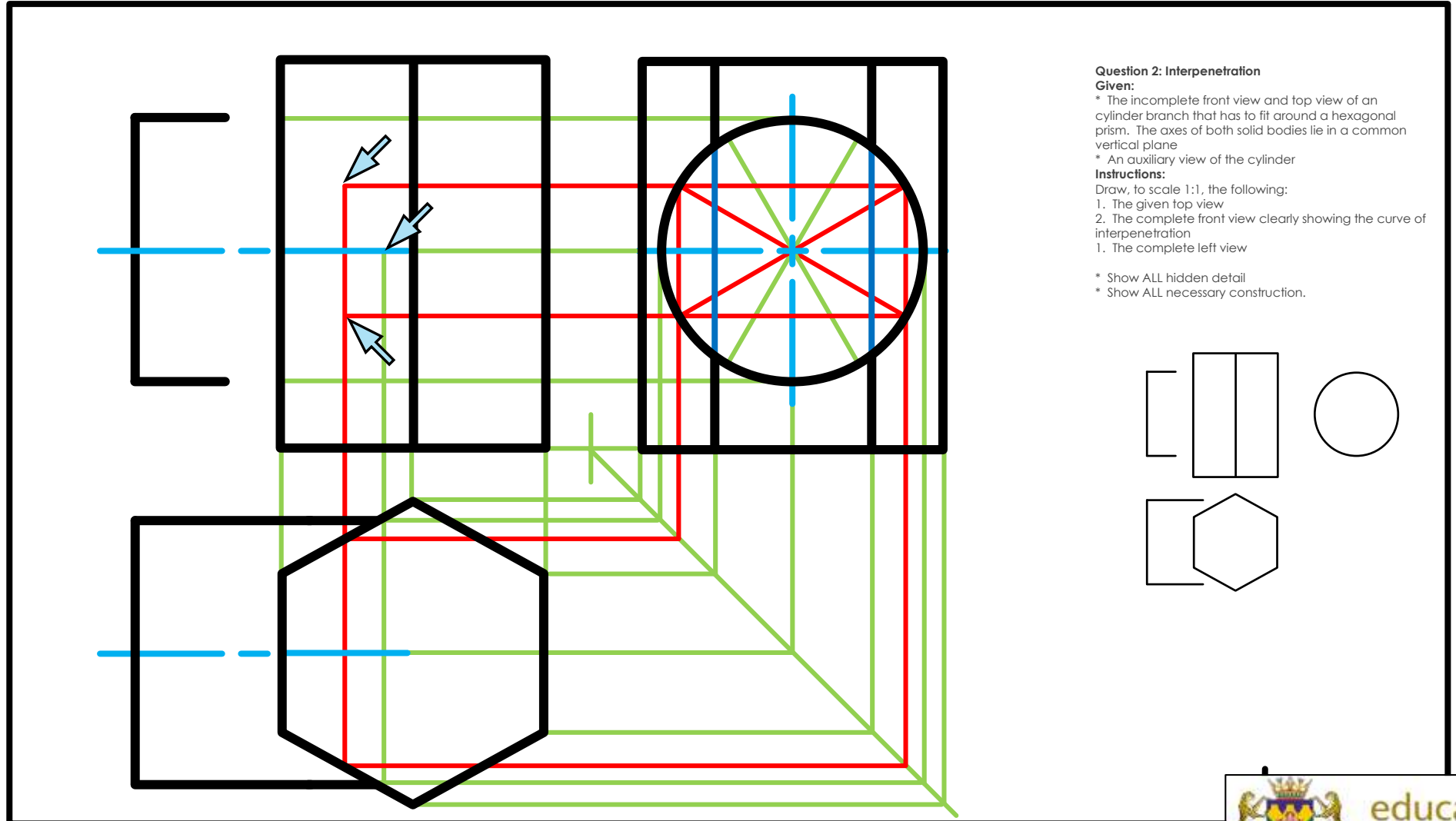
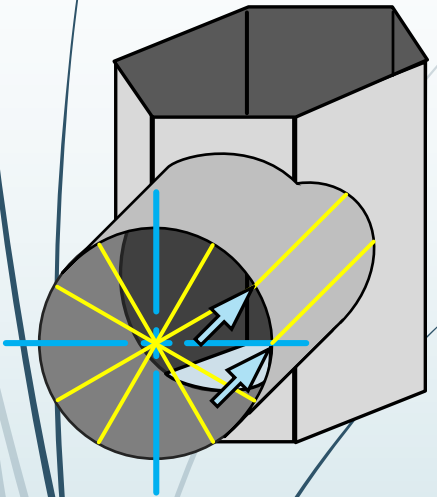

## Question 2: Interpenetration

### Given:

\* The incomplete front view and top view of an cylinder branch that has to fit around a hexagonal prism. The axes of both solid bodies lie in a common vertical plane

\* An auxiliary view of the cylinder

### Instructions:

Draw, to scale 1:1, the following:

1. The given top view
2. The complete front view clearly showing the curve of interpenetration
1. The complete left view

\* Show ALL hidden detail

\* Show ALL necessary construction.

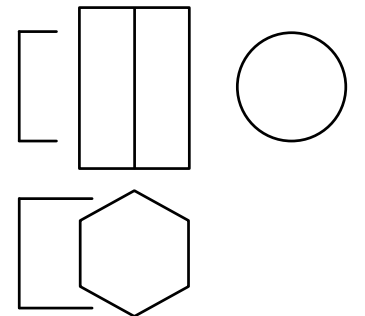

# Interpenetrations

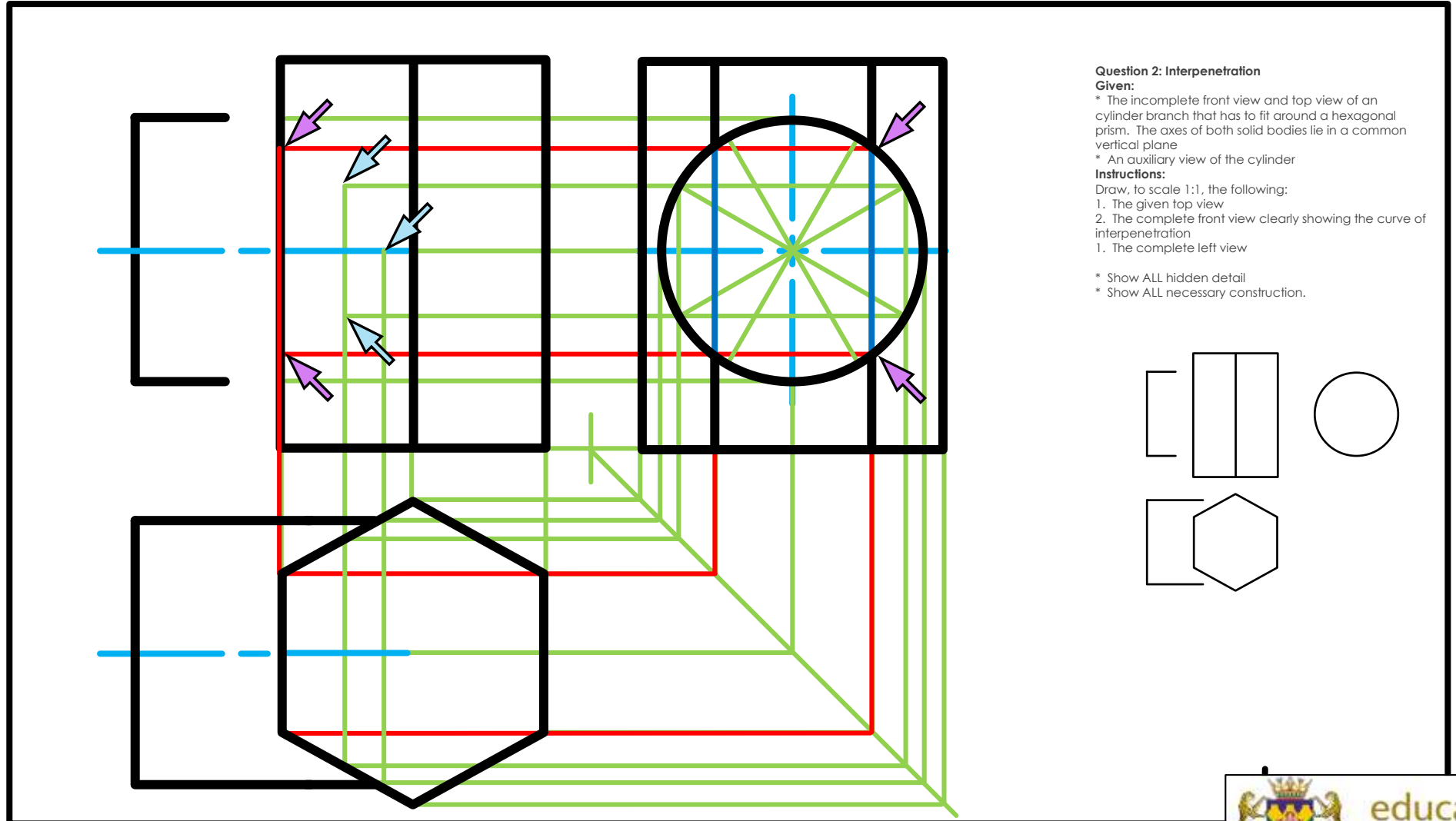
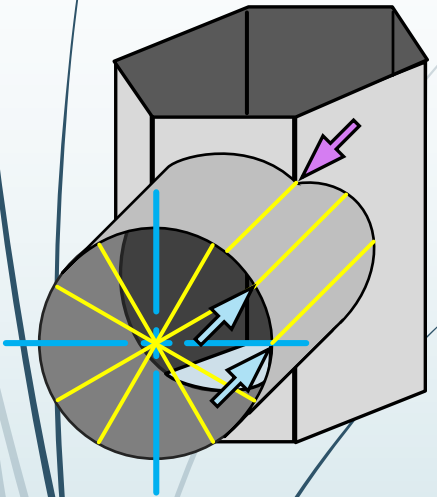

## Question 2: Interpenetration

### Given:

\* The incomplete front view and top view of an cylinder branch that has to fit around a hexagonal prism. The axes of both solid bodies lie in a common vertical plane

\* An auxiliary view of the cylinder

### Instructions:

Draw, to scale 1:1, the following:

1. The given top view
2. The complete front view clearly showing the curve of interpenetration
1. The complete left view

- \* Show ALL hidden detail
- \* Show ALL necessary construction.

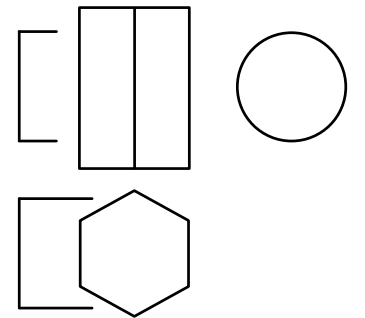

# Interpenetrations

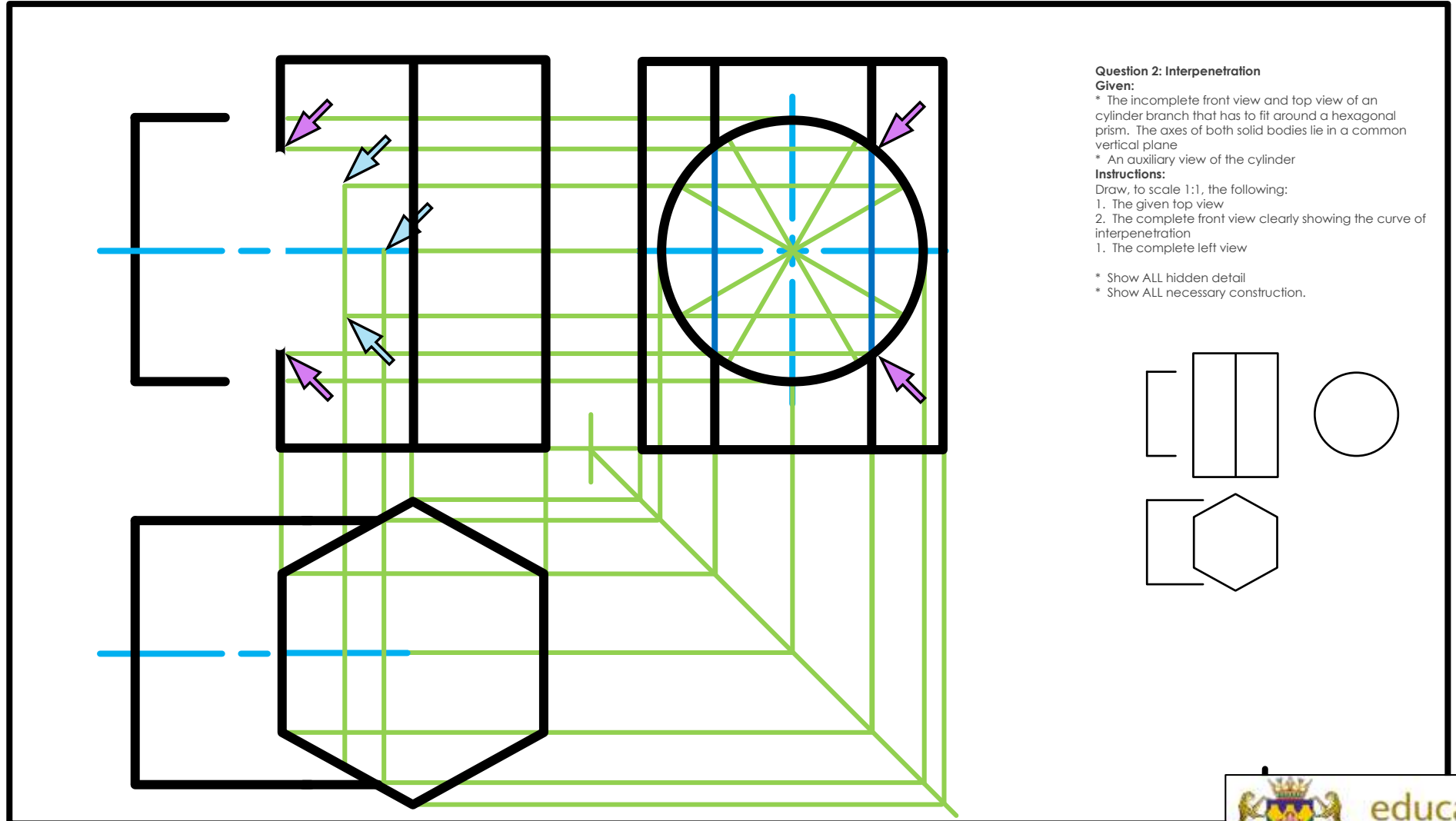
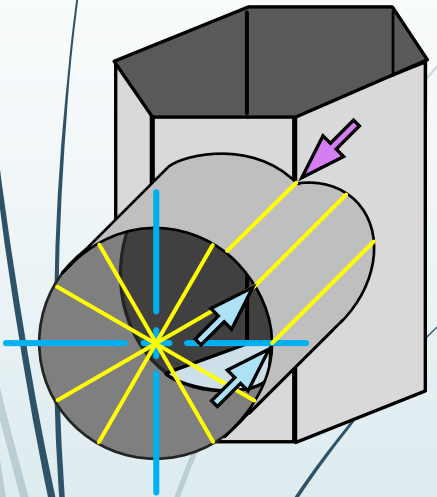

## Question 2: Interpenetration

### Given:

\* The incomplete front view and top view of an cylinder branch that has to fit around a hexagonal prism. The axes of both solid bodies lie in a common vertical plane

\* An auxiliary view of the cylinder

### Instructions:

Draw, to scale 1:1, the following:

1. The given top view
2. The complete front view clearly showing the curve of interpenetration
1. The complete left view

- \* Show ALL hidden detail
- \* Show ALL necessary construction.

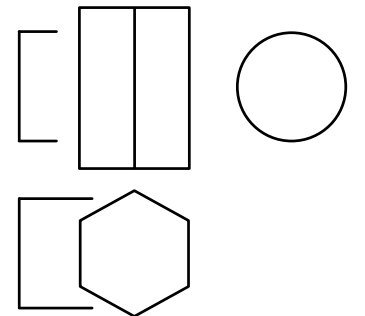

# Interpenetrations

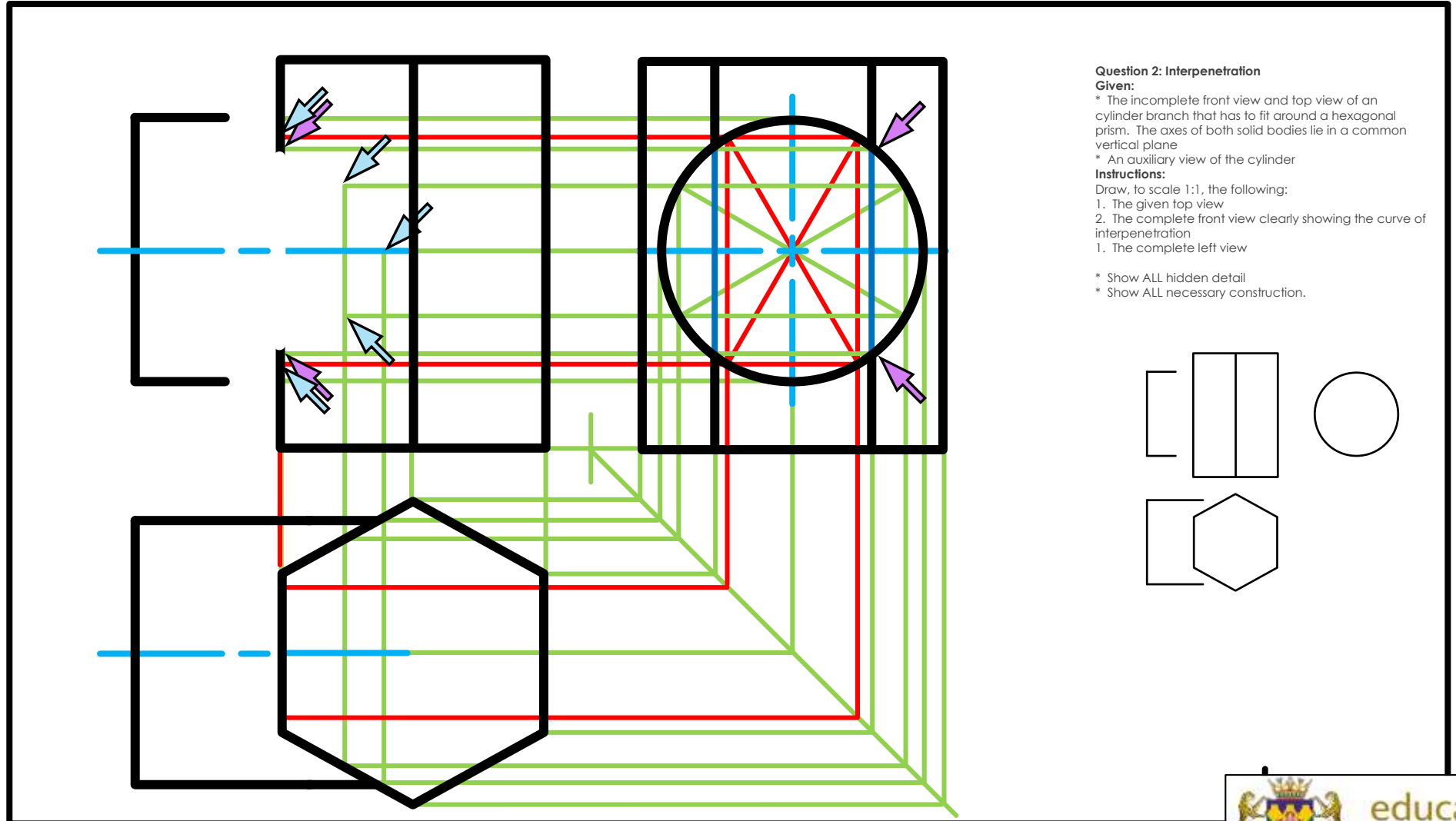
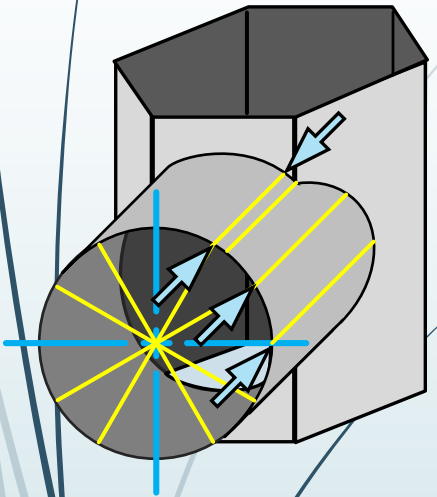

## Question 2: Interpenetration

### Given:

\* The incomplete front view and top view of an cylinder branch that has to fit around a hexagonal prism. The axes of both solid bodies lie in a common vertical plane

\* An auxiliary view of the cylinder

### Instructions:

Draw, to scale 1:1, the following:

1. The given top view
2. The complete front view clearly showing the curve of interpenetration
1. The complete left view

\* Show ALL hidden detail

\* Show ALL necessary construction.

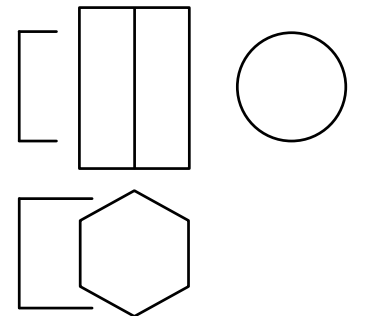

# Interpenetrations

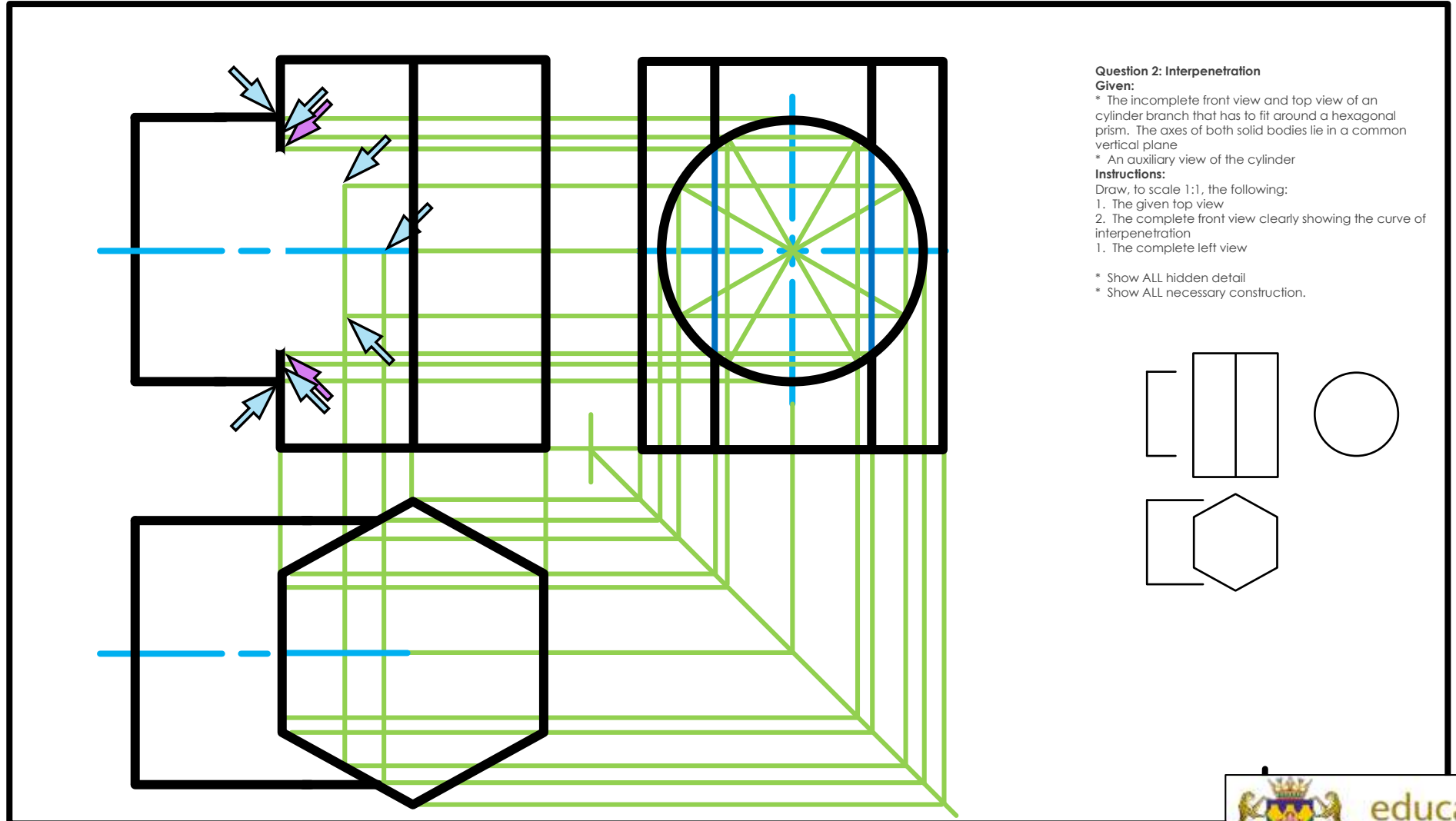
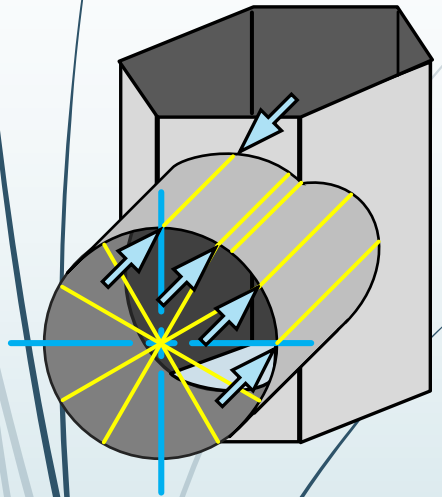

## Question 2: Interpenetration

### Given:

\* The incomplete front view and top view of an cylinder branch that has to fit around a hexagonal prism. The axes of both solid bodies lie in a common vertical plane

\* An auxiliary view of the cylinder

### Instructions:

Draw, to scale 1:1, the following:

1. The given top view
2. The complete front view clearly showing the curve of interpenetration
1. The complete left view

\* Show ALL hidden detail

\* Show ALL necessary construction.

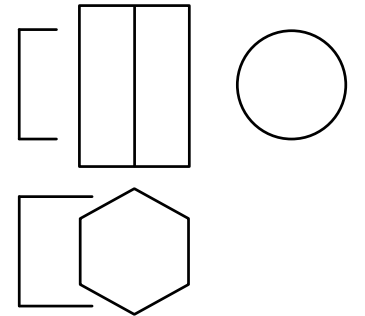

# Interpenetrations

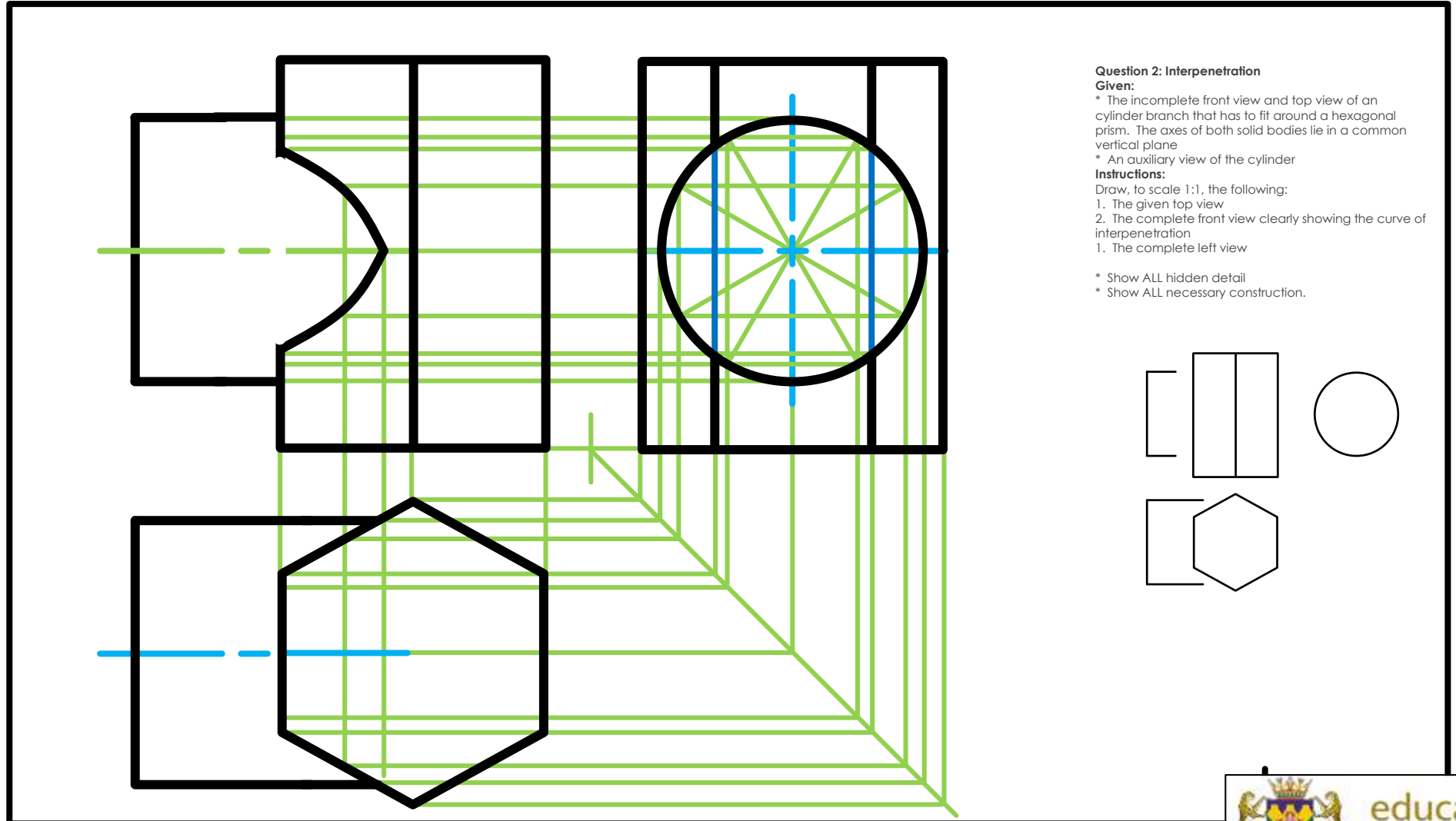
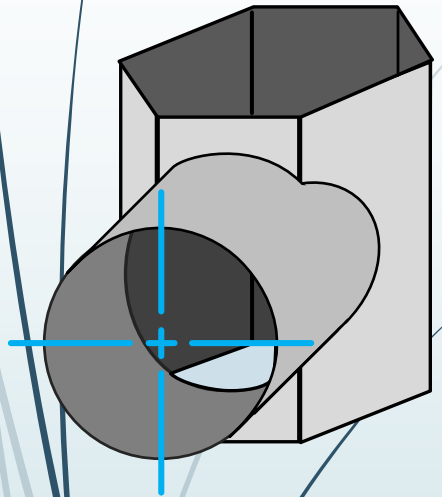

## Question 2: Interpenetration

### Given:

\* The incomplete front view and top view of an cylinder branch that has to fit around a hexagonal prism. The axes of both solid bodies lie in a common vertical plane

\* An auxiliary view of the cylinder

### Instructions:

Draw, to scale 1:1, the following:

1. The given top view
2. The complete front view clearly showing the curve of interpenetration
1. The complete left view

\* Show ALL hidden detail

\* Show ALL necessary construction.

