

Interpenetrations

EGD Grade 11 & 12

Developed by: PC Viljoen
Senior Educational Specialist for
Engineering Graphics and Design
Free State Province

Interpenetrations

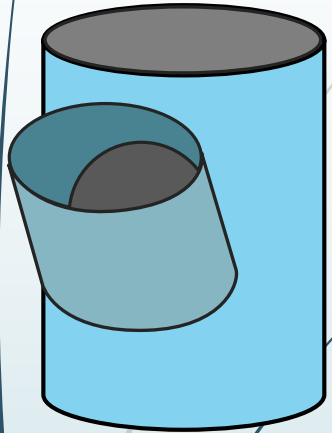

Question 2: Interpenetration

Given:

- * The incomplete front view and top view of a cylinder at 45° that has to fit around another cylinder. The axes of both cylinders lie in a common vertical plane.
- * Auxiliary view of the branch cylinder.

Instructions:

Draw, to scale 1:1, the following:

1. The given top view.
2. The complete front view clearly showing the curve of interpenetration.
3. The complete left view.
3. Develop the main cylinder and to show the interpenetration clearly.
4. Develop the branch cylinder.

- * Show ALL hidden detail.
- * Show ALL necessary construction.

Question 2: Interpenetration

Given:

- * The incomplete front view and top view of a cylinder at 45° that has to fit around another cylinder. The axes of both cylinders lie in a common vertical plane.
- * Auxiliary view of the branch cylinder.

Instructions:

Draw, to scale 1:1, the following:

1. The given top view.
2. The complete front view clearly showing the curve of interpenetration.
2. The complete left view.
3. Develop the main cylinder and to show the interpenetration clearly. Develop the branch cylinder.

* Show ALL hidden detail.

* Show ALL necessary construction.

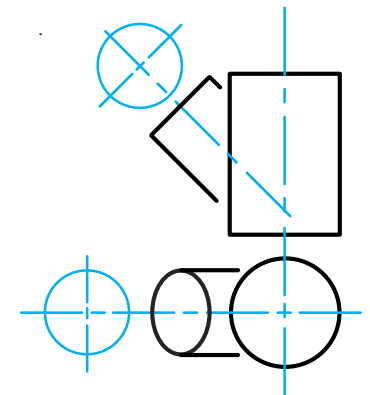

Interpenetrations

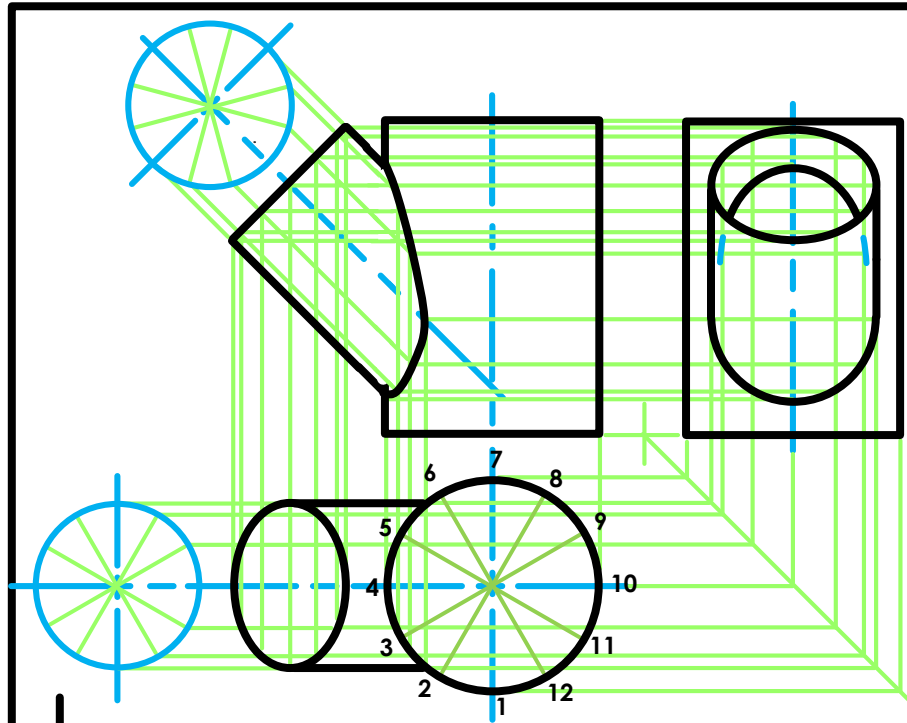
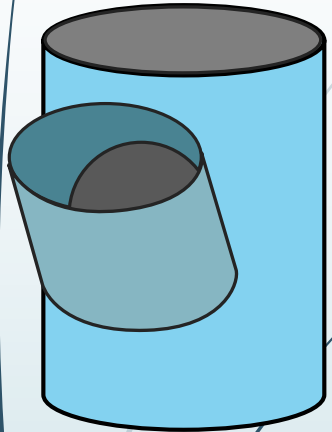

$$\begin{aligned}
 A &= 2\pi r \\
 &= 2 \times 3,141592654 \times 25 \\
 &= 157 \text{ mm}
 \end{aligned}$$

Question 2: Interpenetration

Given:

- * The incomplete front view and top view of a cylinder of 45° that has to fit around another cylinder. The axes of both cylinders lie in a common vertical plane.
- * Auxiliary view of the branch cylinder.

Instructions:

Draw, to scale 1:1, the following:

1. The given top view.
2. The complete front view clearly showing the curve of interpenetration.
3. The complete left view.

* Show ALL hidden detail.

* Show ALL necessary construction.

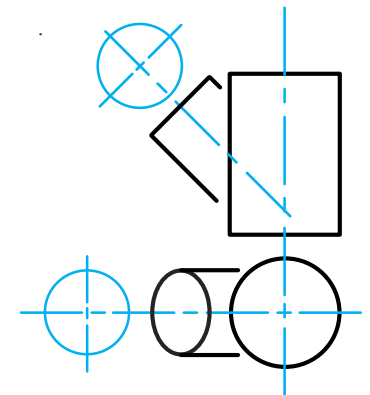

A



education

Department of Education
FREE STATE PROVINCE

Interpenetrations

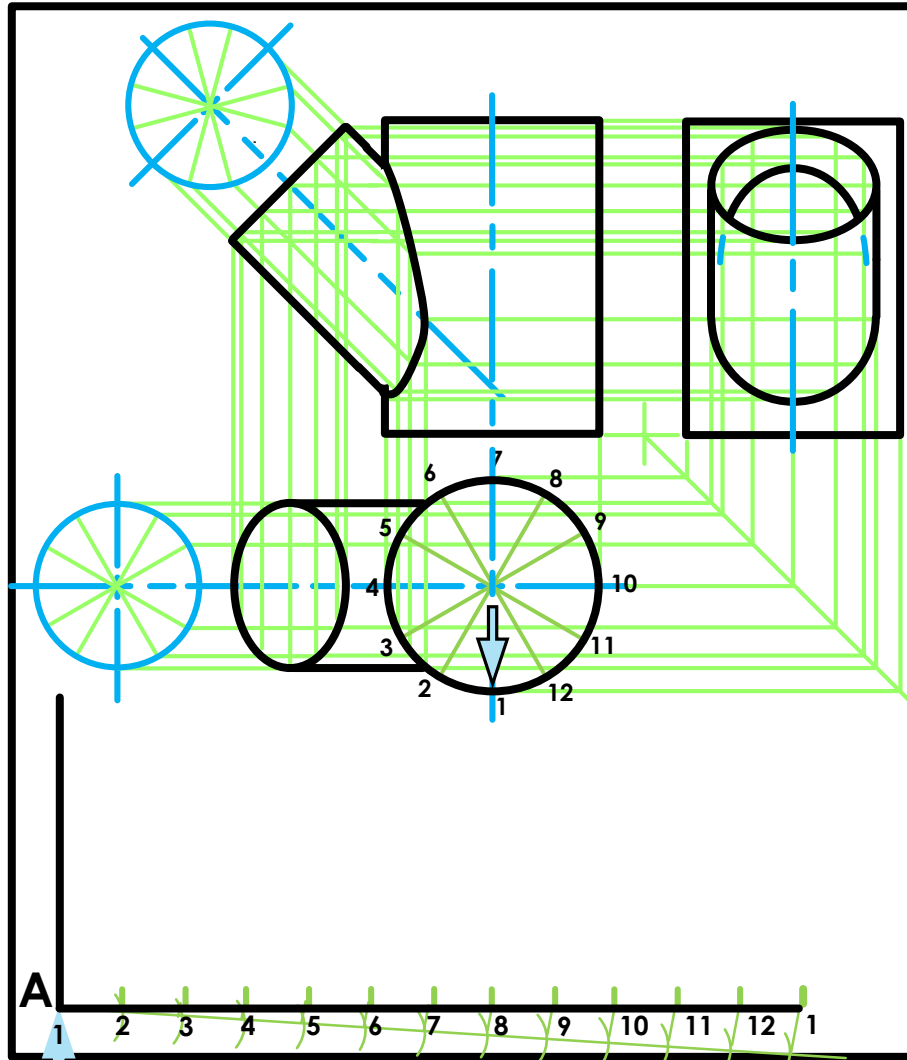
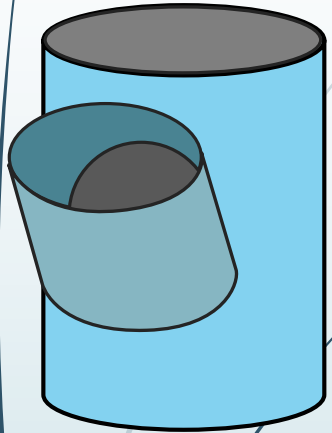

$$\begin{aligned}
 A &= 2\pi r \\
 &= 2 \times 3,141592654 \times 25 \\
 &= 157 \text{ mm} \\
 &= \frac{157}{12} \\
 &= 13
 \end{aligned}$$

Question 2: Interpenetration

Given:

- * The incomplete front view and top view of a cylinder of 45° that has to fit around another cylinder. The axes of both cylinders lie in a common vertical plane.
- * Auxiliary view of the branch cylinder.

Instructions:

Draw, to scale 1:1, the following:

1. The given top view.
2. The complete front view clearly showing the curve of interpenetration.
3. The complete left view.

* Show ALL hidden detail.

* Show ALL necessary construction.

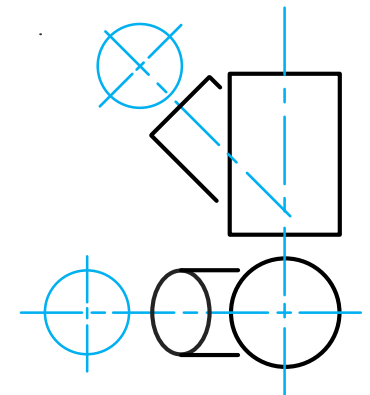

Interpenetrations

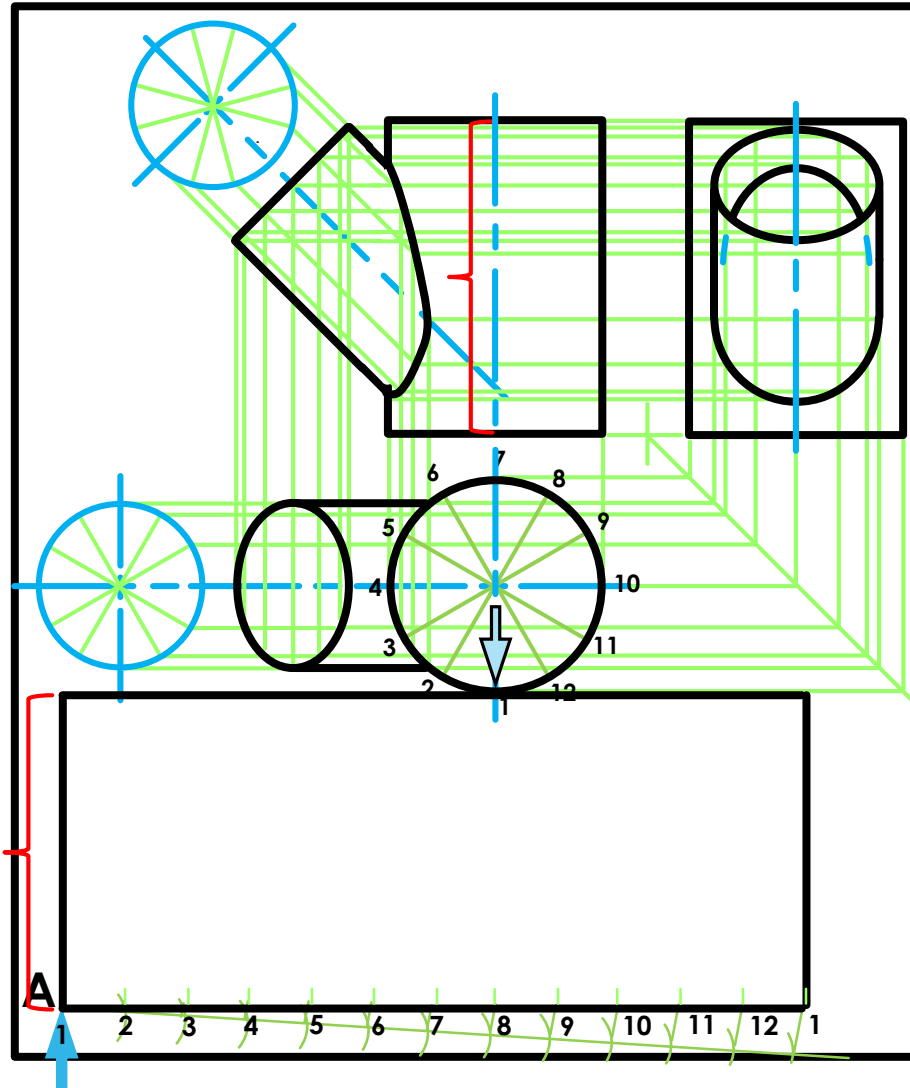
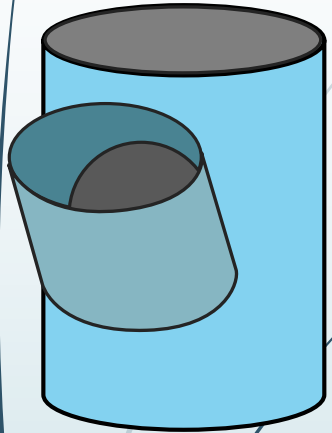

$$\begin{aligned}
 A &= 2\pi r \\
 &= 2 \times 3,141592654 \times 25 \\
 &= 157 \text{ mm} \\
 &= \frac{157}{12} \\
 &= 13
 \end{aligned}$$

Question 2: Interpenetration

Given:

- * The incomplete front view and top view of a cylinder of 45° that has to fit around another cylinder. The axes of both cylinders lie in a common vertical plane.
- * Auxiliary view of the branch cylinder.

Instructions:

Draw, to scale 1:1, the following:

1. The given top view.
2. The complete front view clearly showing the curve of interpenetration.
3. The complete left view.

* Show ALL hidden detail.

* Show ALL necessary construction.

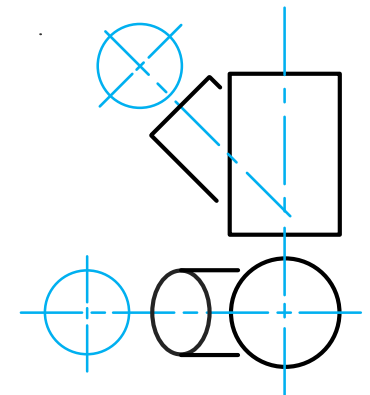

Interpenetrations

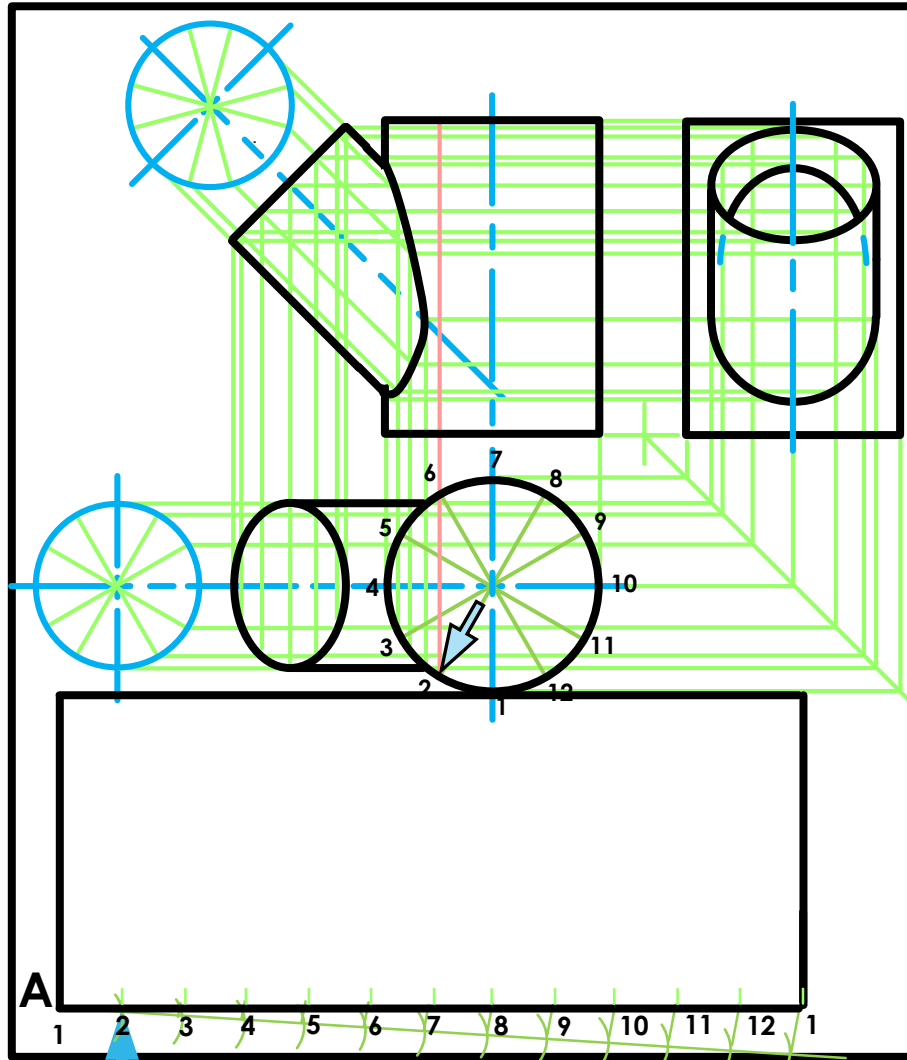
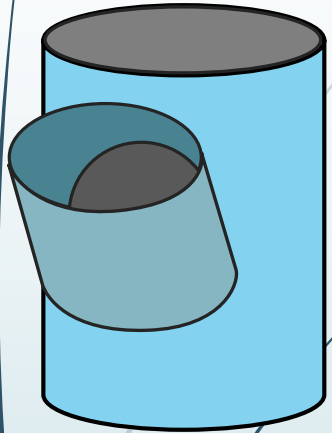

$$\begin{aligned}
 A &= 2\pi r \\
 &= 2 \times 3,141592654 \times 25 \\
 &= 157 \text{ mm} \\
 &= \frac{157}{12} \\
 &= 13
 \end{aligned}$$

Question 2: Interpenetration

Given:

- * The incomplete front view and top view of a cylinder of 45° that has to fit around another cylinder. The axes of both cylinders lie in a common vertical plane.
- * Auxiliary view of the branch cylinder.

Instructions:

Draw, to scale 1:1, the following:

1. The given top view.
2. The complete front view clearly showing the curve of interpenetration.
3. The complete left view.

* Show ALL hidden detail.

* Show ALL necessary construction.

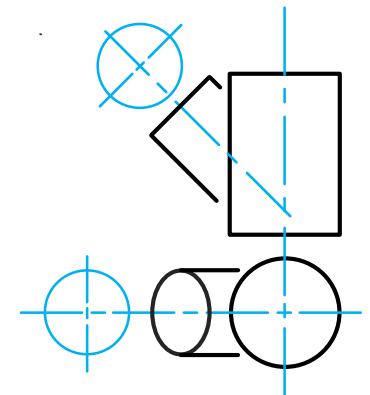

Interpenetrations

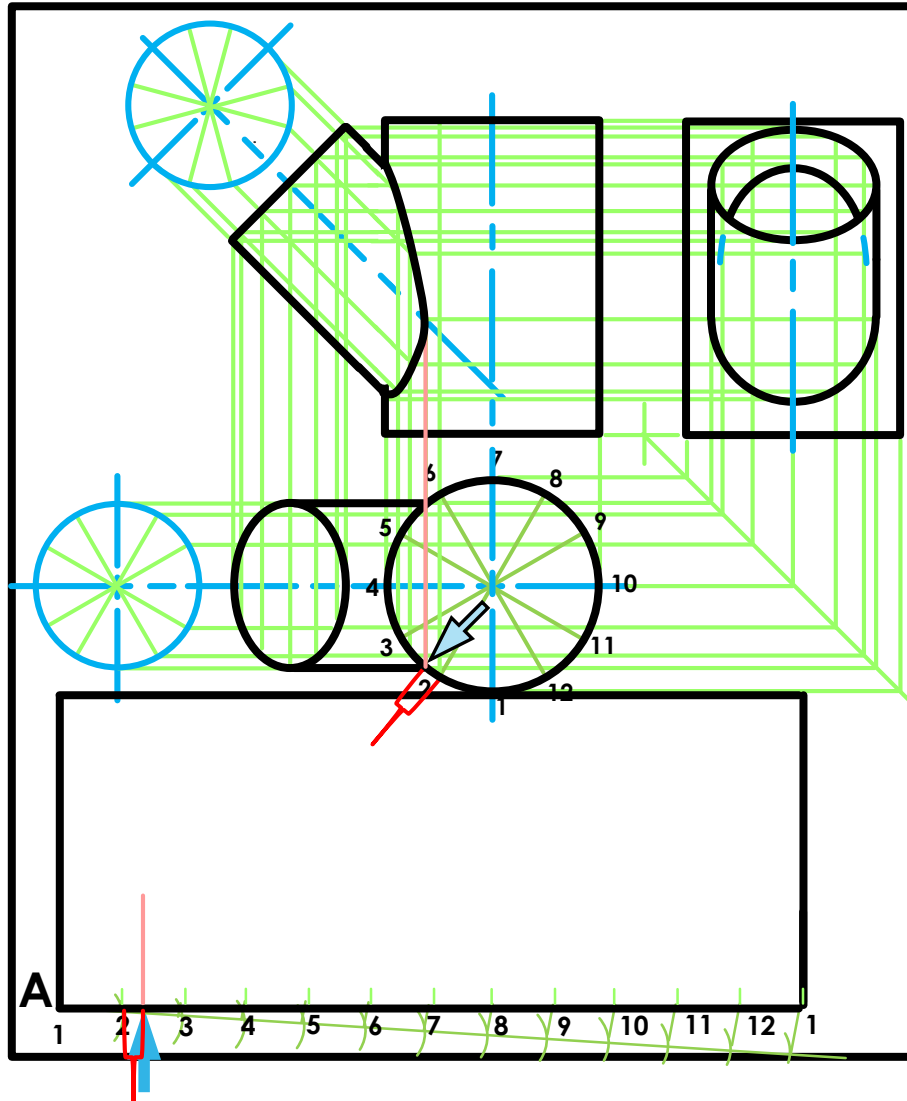
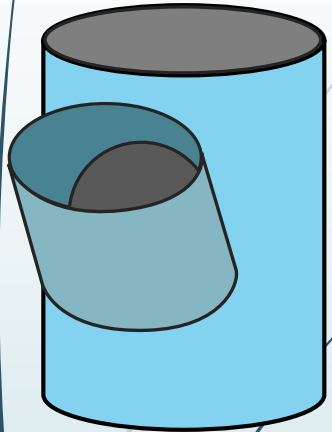

$$\begin{aligned}
 A &= 2\pi r \\
 &= 2 \times 3,141592654 \times 25 \\
 &= 157 \text{ mm} \\
 &= \frac{157}{12} \\
 &= 13
 \end{aligned}$$

Question 2: Interpenetration

Given:

- * The incomplete front view and top view of a cylinder of 45° that has to fit around another cylinder. The axes of both cylinders lie in a common vertical plane.
- * Auxiliary view of the branch cylinder.

Instructions:

Draw, to scale 1:1, the following:

1. The given top view.
2. The complete front view clearly showing the curve of interpenetration.
3. The complete left view.

* Show ALL hidden detail.

* Show ALL necessary construction.

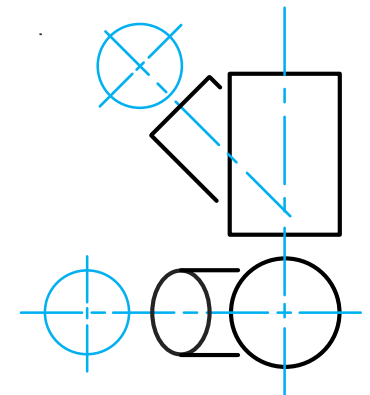

Interpenetrations

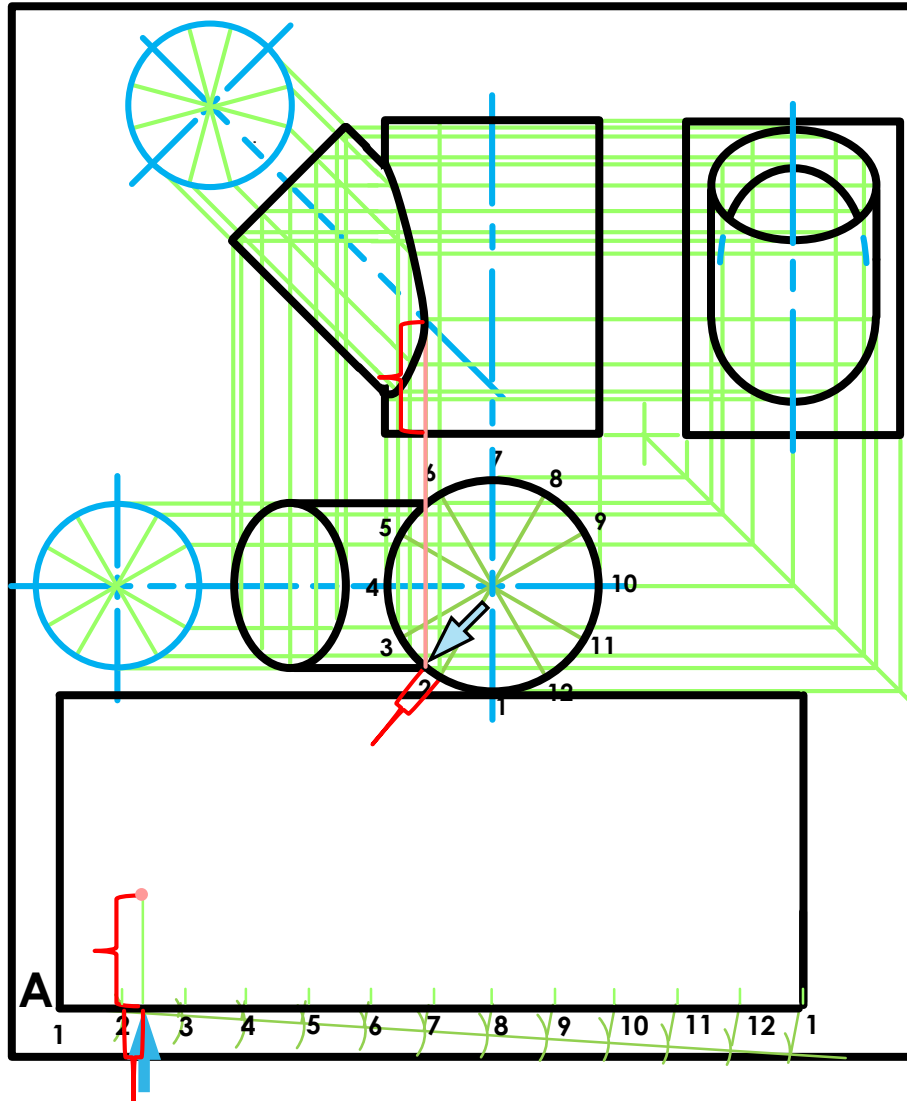
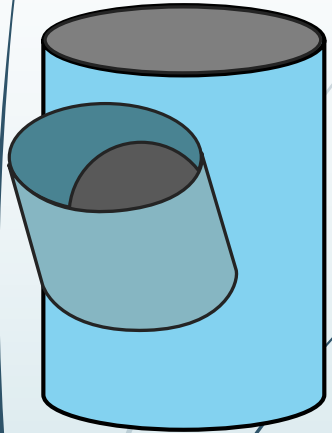

$$\begin{aligned}
 A &= 2\pi r \\
 &= 2 \times 3,141592654 \times 25 \\
 &= 157 \text{ mm} \\
 &= \frac{157}{12} \\
 &= 13
 \end{aligned}$$

Question 2: Interpenetration

Given:

- * The incomplete front view and top view of a cylinder of 45° that has to fit around another cylinder. The axes of both cylinders lie in a common vertical plane.
- * Auxiliary view of the branch cylinder.

Instructions:

Draw, to scale 1:1, the following:

1. The given top view.
2. The complete front view clearly showing the curve of interpenetration.
3. The complete left view.

* Show ALL hidden detail.

* Show ALL necessary construction.

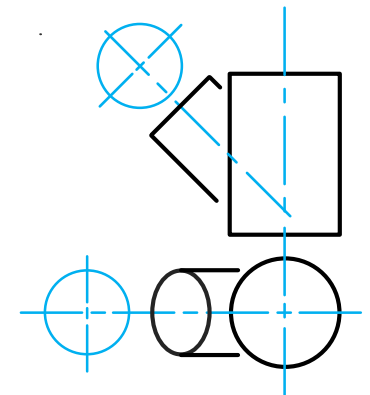

Interpenetrations

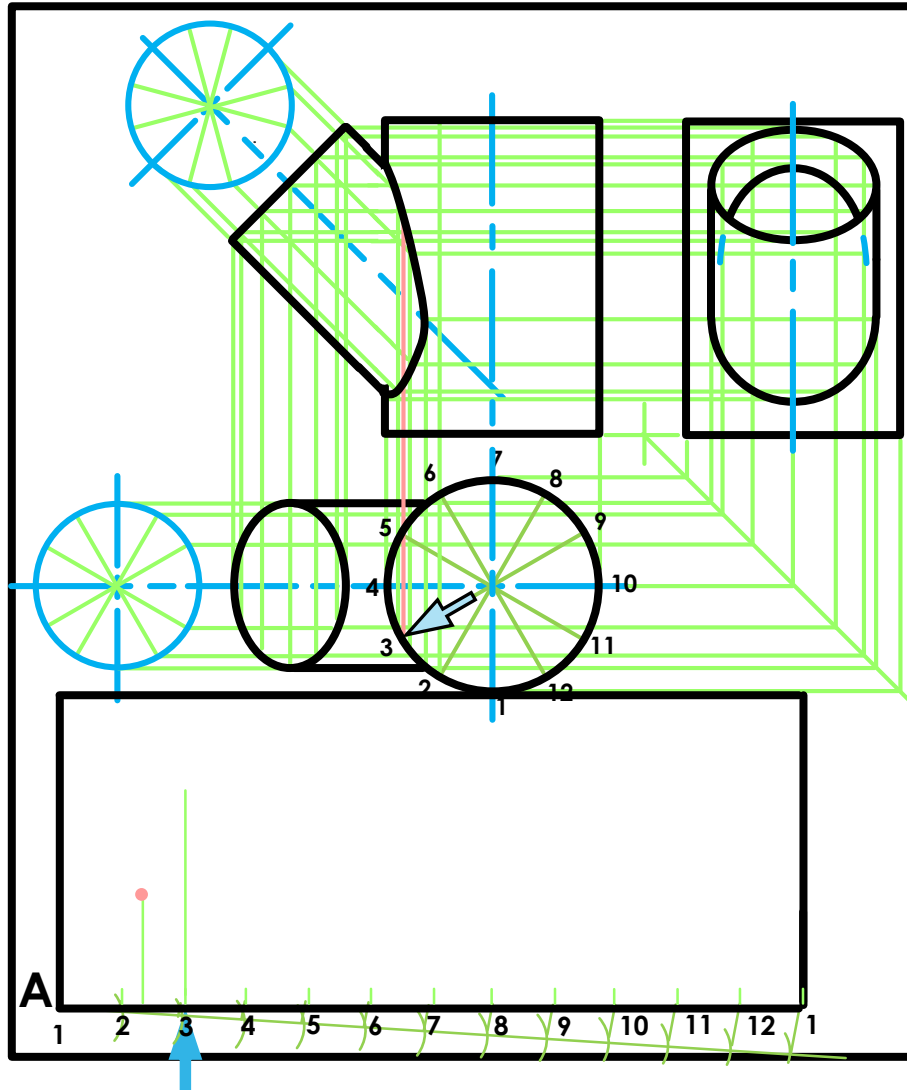
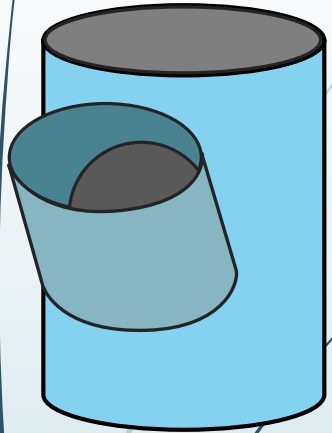

$$\begin{aligned}
 A &= 2\pi r \\
 &= 2 \times 3,141592654 \times 25 \\
 &= 157 \text{ mm} \\
 &= \frac{157}{12} \\
 &= 13
 \end{aligned}$$

Question 2: Interpenetration

Given:

- * The incomplete front view and top view of a cylinder of 45° that has to fit around another cylinder. The axes of both cylinders lie in a common vertical plane.
- * Auxiliary view of the branch cylinder.

Instructions:

Draw, to scale 1:1, the following:

1. The given top view.
2. The complete front view clearly showing the curve of interpenetration.
3. The complete left view.

* Show ALL hidden detail.

* Show ALL necessary construction.

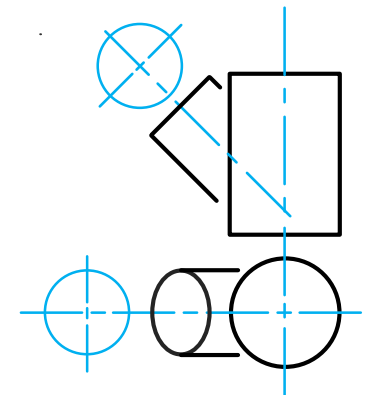

Interpenetrations

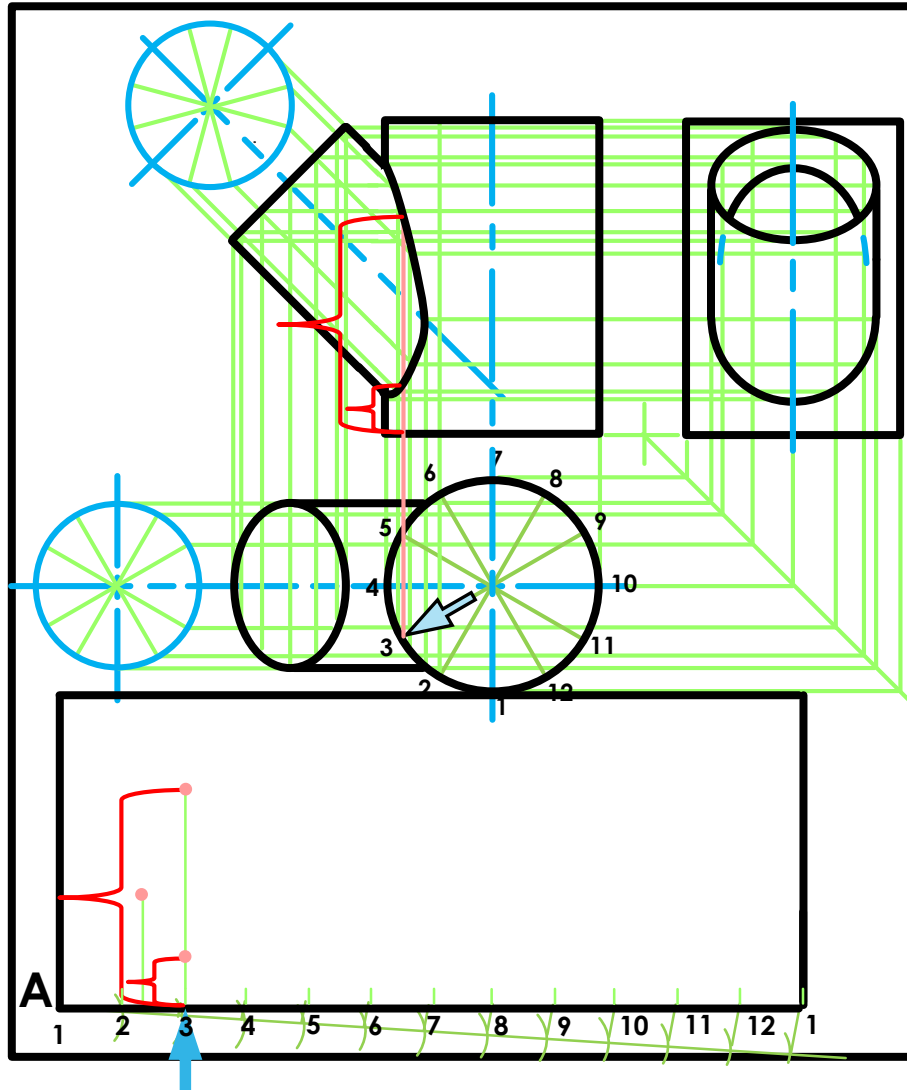
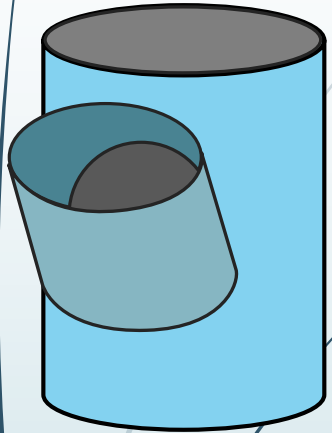

$$\begin{aligned}
 A &= 2\pi r \\
 &= 2 \times 3,141592654 \times 25 \\
 &= 157 \text{ mm} \\
 &= \frac{157}{12} \\
 &= 13
 \end{aligned}$$

Question 2: Interpenetration

Given:

- * The incomplete front view and top view of a cylinder of 45° that has to fit around another cylinder. The axes of both cylinders lie in a common vertical plane.
- * Auxiliary view of the branch cylinder.

Instructions:

Draw, to scale 1:1, the following:

1. The given top view.
2. The complete front view clearly showing the curve of interpenetration.
3. The complete left view.

* Show ALL hidden detail.

* Show ALL necessary construction.

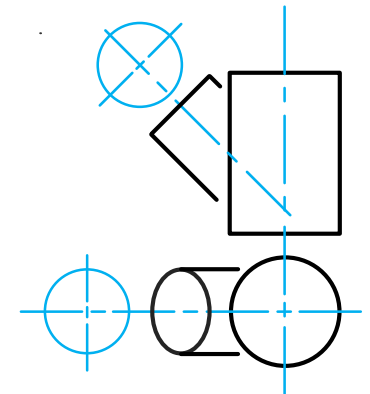

Interpenetrations

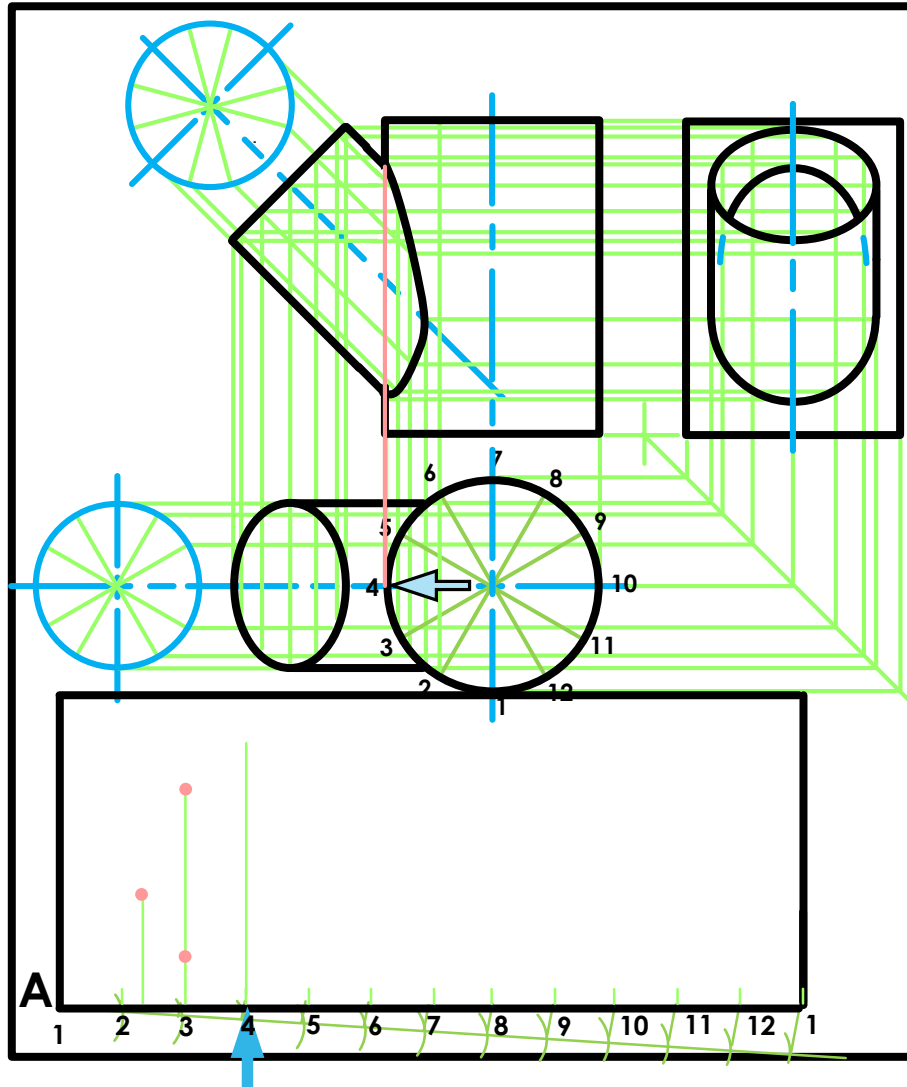
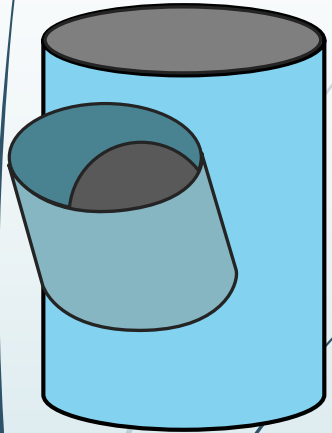

$$\begin{aligned}
 A &= 2\pi r \\
 &= 2 \times 3,141592654 \times 25 \\
 &= 157 \text{ mm} \\
 &= \frac{157}{12} \\
 &= 13
 \end{aligned}$$

Question 2: Interpenetration

Given:

- * The incomplete front view and top view of a cylinder of 45° that has to fit around another cylinder. The axes of both cylinders lie in a common vertical plane.
- * Auxiliary view of the branch cylinder.

Instructions:

Draw, to scale 1:1, the following:

1. The given top view.
2. The complete front view clearly showing the curve of interpenetration.
3. The complete left view.

* Show ALL hidden detail.

* Show ALL necessary construction.

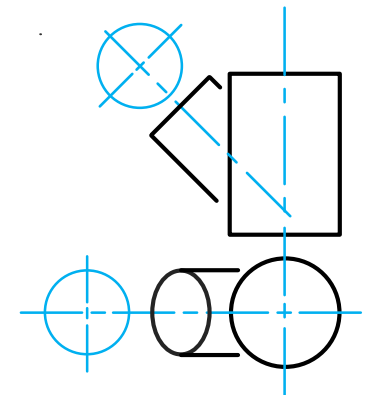

Interpenetrations

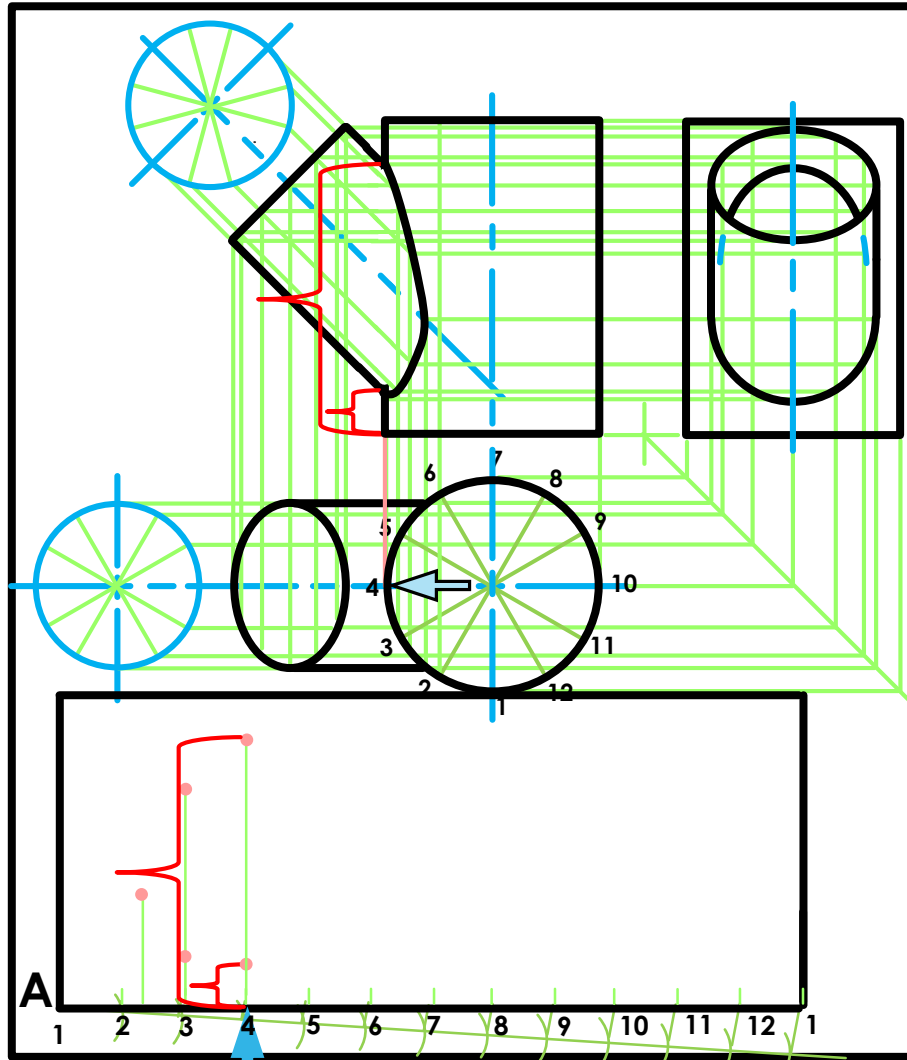
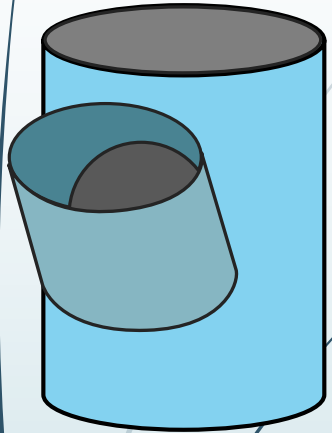

$$\begin{aligned}
 A &= 2\pi r \\
 &= 2 \times 3,141592654 \times 25 \\
 &= 157 \text{ mm} \\
 &= \frac{157}{12} \\
 &= 13
 \end{aligned}$$

Question 2: Interpenetration

Given:

- * The incomplete front view and top view of a cylinder of 45° that has to fit around another cylinder. The axes of both cylinders lie in a common vertical plane.
- * Auxiliary view of the branch cylinder.

Instructions:

Draw, to scale 1:1, the following:

1. The given top view.
2. The complete front view clearly showing the curve of interpenetration.
3. The complete left view.

* Show ALL hidden detail.

* Show ALL necessary construction.

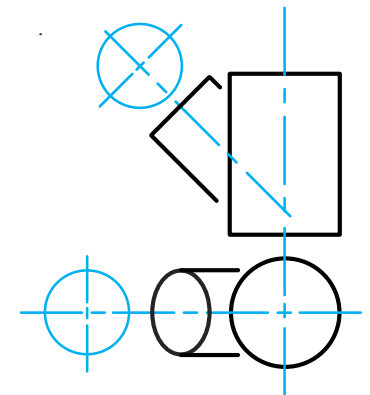

Interpenetrations

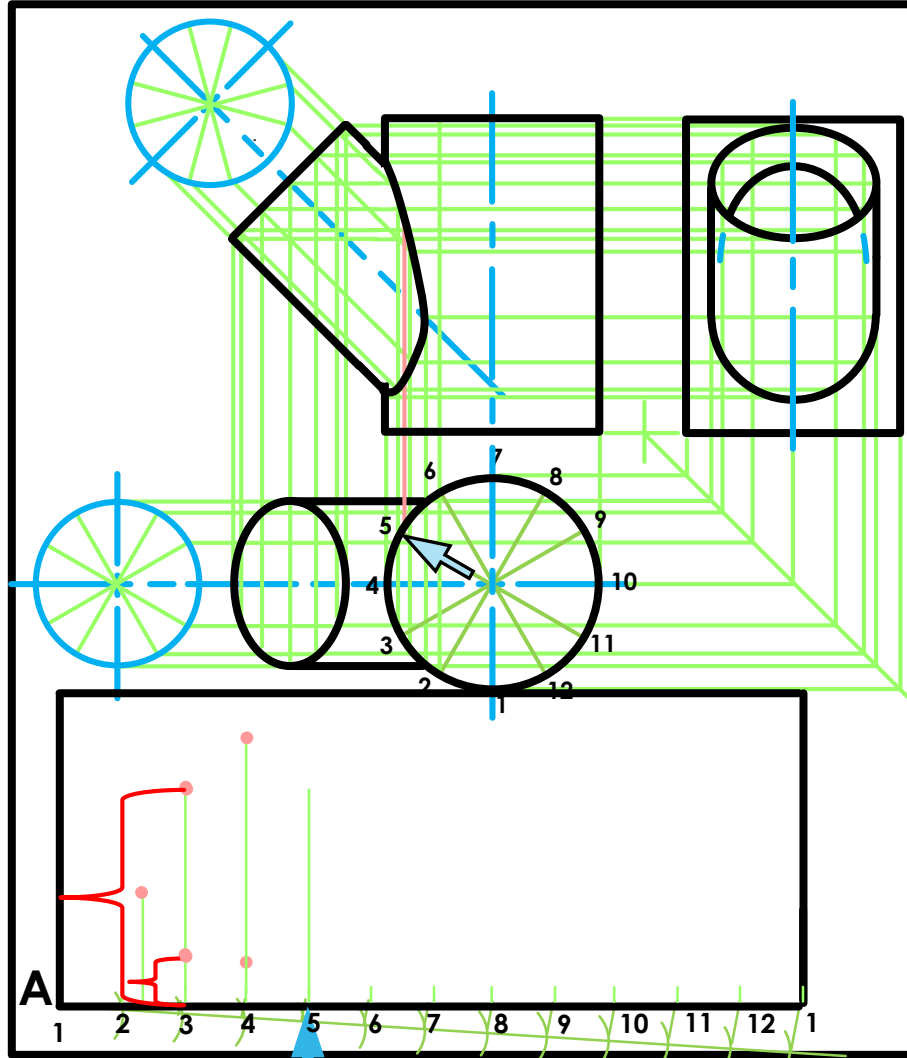
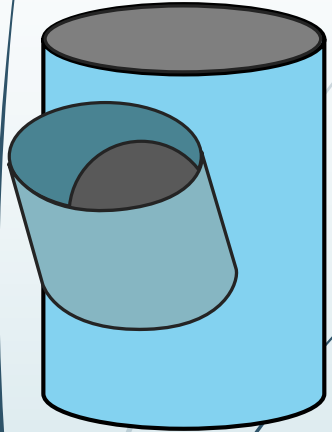

$$\begin{aligned}
 A &= 2\pi r \\
 &= 2 \times 3,141592654 \times 25 \\
 &= 157 \text{ mm} \\
 &= \frac{157}{12} \\
 &= 13
 \end{aligned}$$

Question 2: Interpenetration

Given:

- * The incomplete front view and top view of a cylinder of 45° that has to fit around another cylinder. The axes of both cylinders lie in a common vertical plane.
- * Auxiliary view of the branch cylinder.

Instructions:

Draw, to scale 1:1, the following:

1. The given top view.
2. The complete front view clearly showing the curve of interpenetration.
3. The complete left view.

* Show ALL hidden detail.

* Show ALL necessary construction.

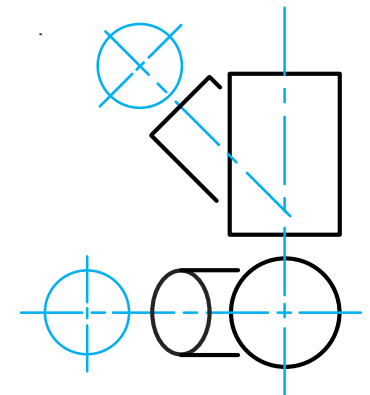

Interpenetrations

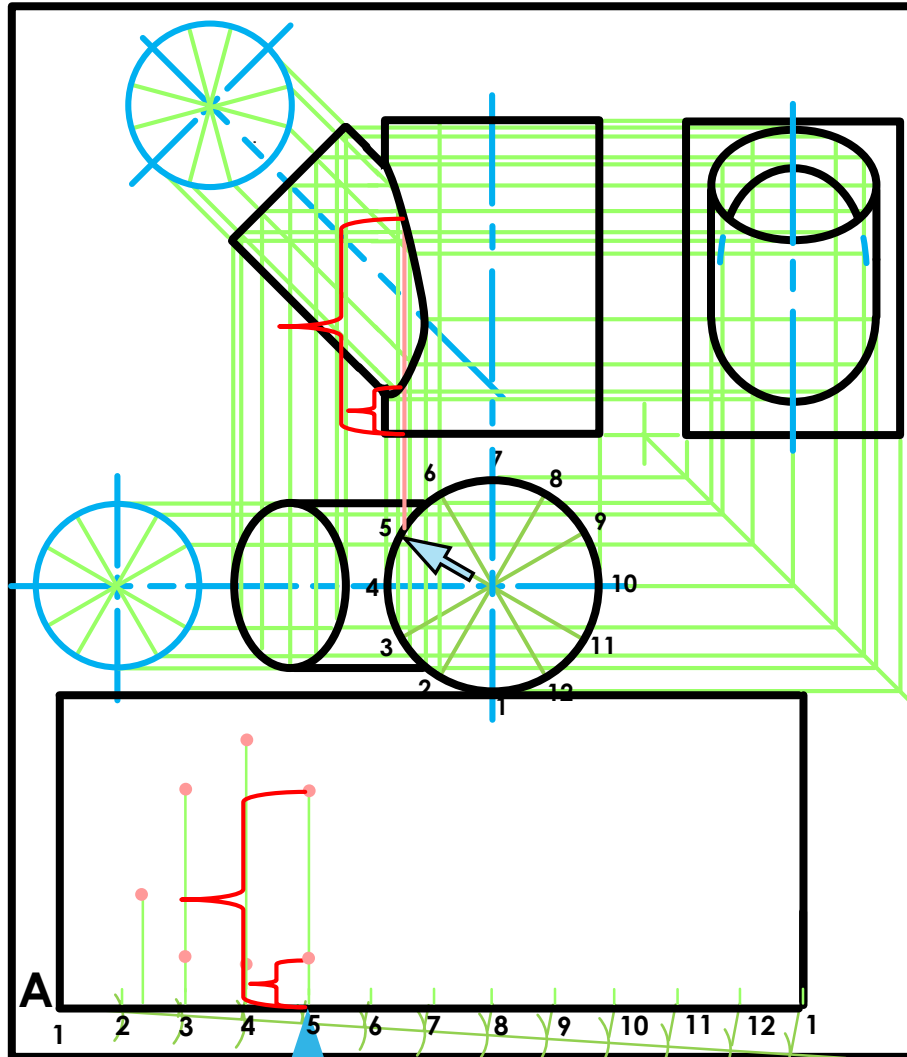
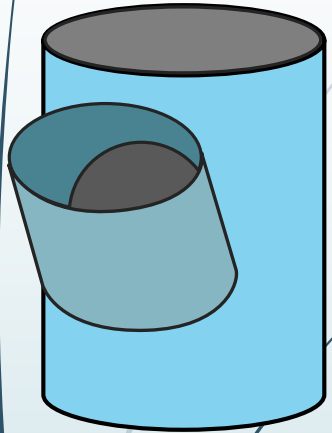

$$\begin{aligned}
 A &= 2\pi r \\
 &= 2 \times 3,141592654 \times 25 \\
 &= 157 \text{ mm} \\
 &= \frac{157}{12} \\
 &= 13
 \end{aligned}$$

Question 2: Interpenetration

Given:

- * The incomplete front view and top view of a cylinder of 45° that has to fit around another cylinder. The axes of both cylinders lie in a common vertical plane.
- * Auxiliary view of the branch cylinder.

Instructions:

Draw, to scale 1:1, the following:

1. The given top view.
2. The complete front view clearly showing the curve of interpenetration.
3. The complete left view.

* Show ALL hidden detail.

* Show ALL necessary construction.

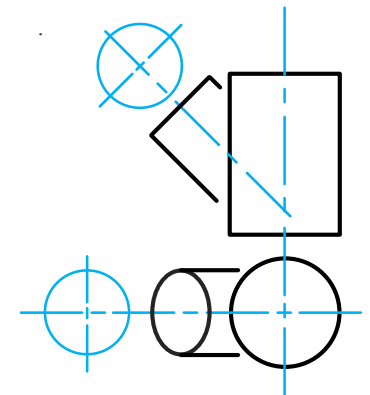

Interpenetrations

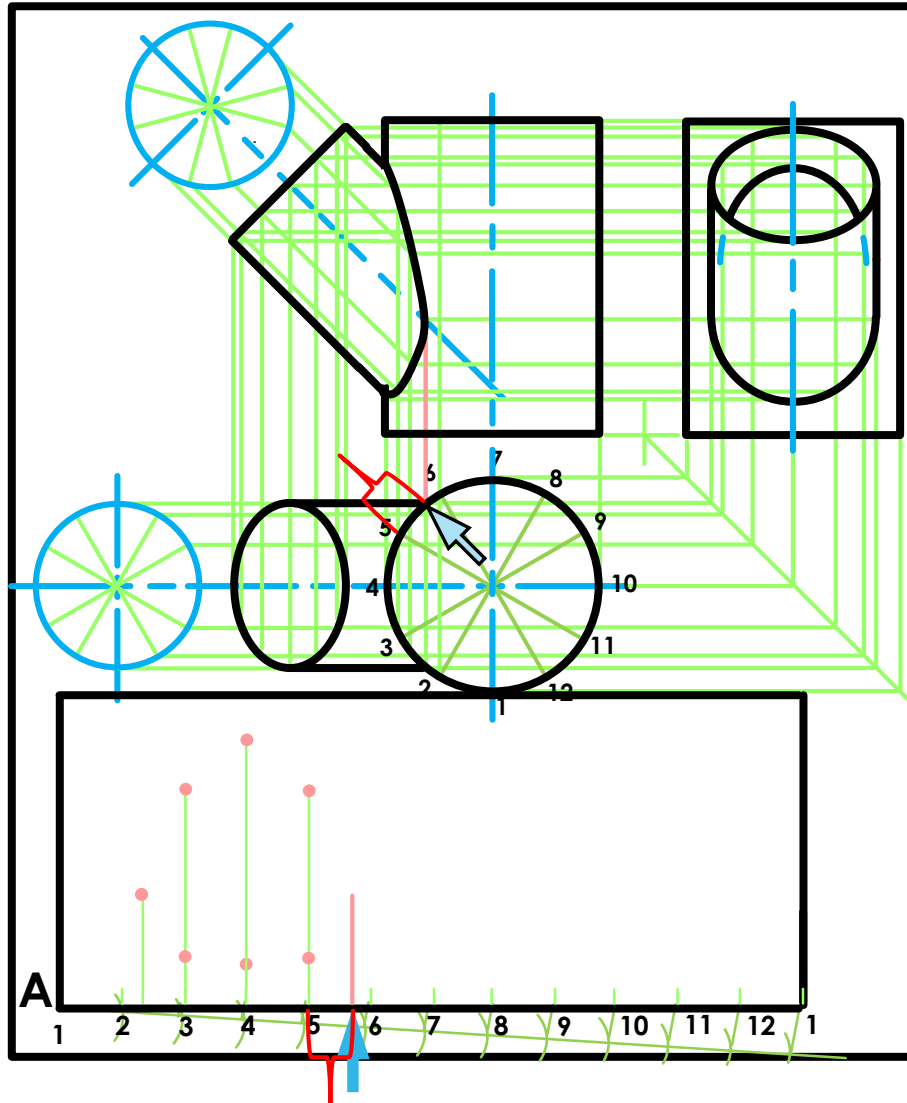
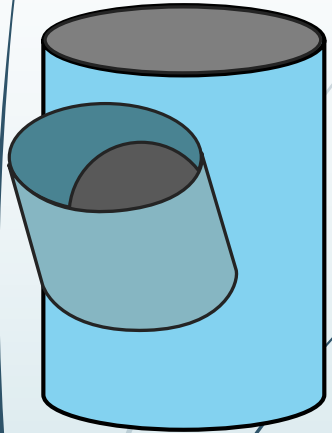

$$\begin{aligned}
 A &= 2\pi r \\
 &= 2 \times 3,141592654 \times 25 \\
 &= 157 \text{ mm} \\
 &= \frac{157}{12} \\
 &= 13
 \end{aligned}$$

Question 2: Interpenetration

Given:

- * The incomplete front view and top view of a cylinder of 45° that has to fit around another cylinder. The axes of both cylinders lie in a common vertical plane.
- * Auxiliary view of the branch cylinder.

Instructions:

Draw, to scale 1:1, the following:

1. The given top view.
2. The complete front view clearly showing the curve of interpenetration.
3. The complete left view.

* Show ALL hidden detail.

* Show ALL necessary construction.

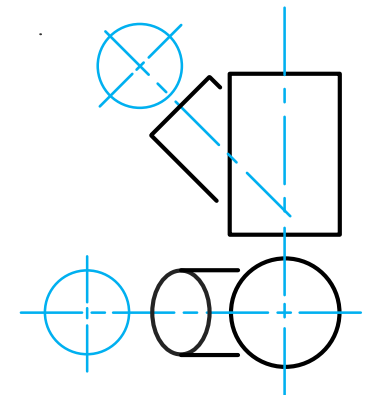

Interpenetrations

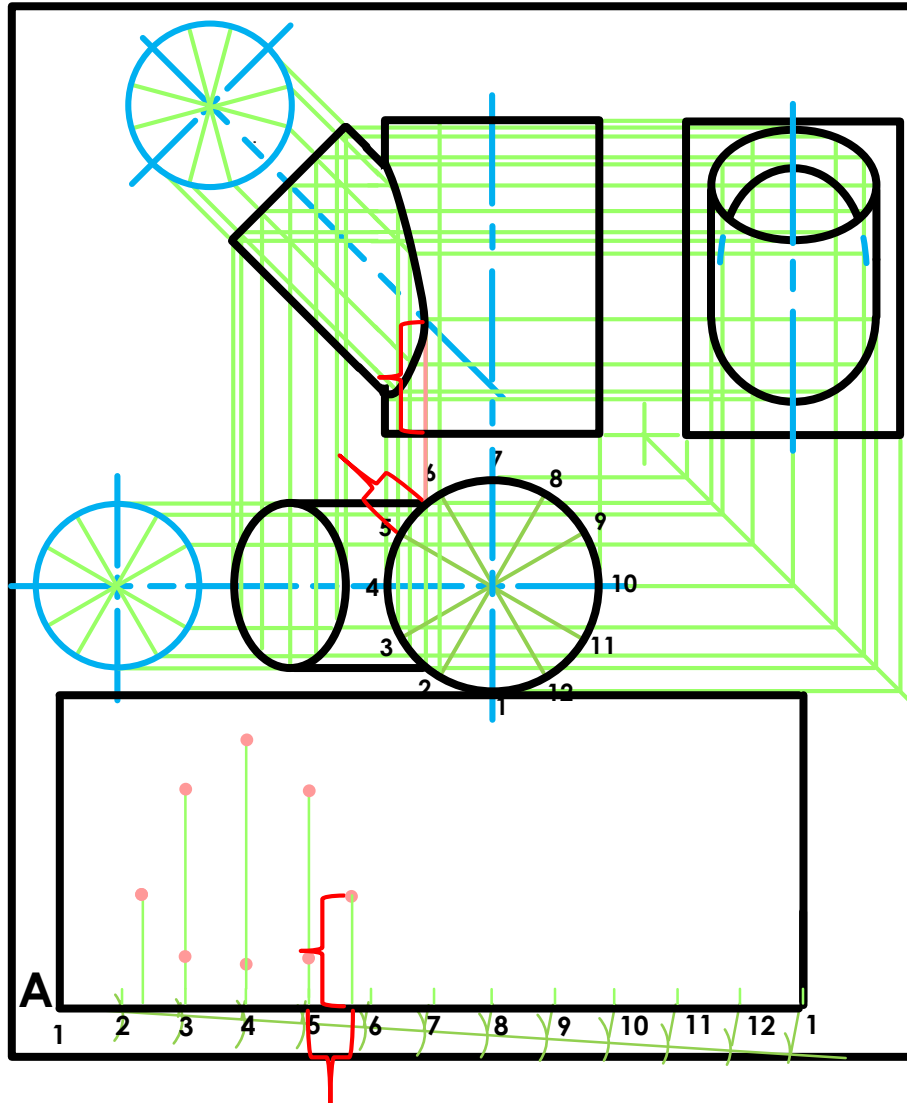
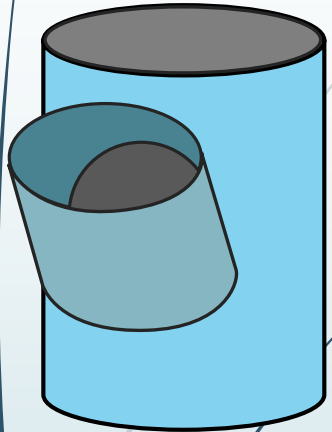

$$\begin{aligned}
 A &= 2\pi r \\
 &= 2 \times 3,141592654 \times 25 \\
 &= 157 \text{ mm} \\
 &= \frac{157}{12} \\
 &= 13
 \end{aligned}$$

Question 2: Interpenetration

Given:

- * The incomplete front view and top view of a cylinder of 45° that has to fit around another cylinder. The axes of both cylinders lie in a common vertical plane.
- * Auxiliary view of the branch cylinder.

Instructions:

Draw, to scale 1:1, the following:

1. The given top view.
2. The complete front view clearly showing the curve of interpenetration.
3. The complete left view.

* Show ALL hidden detail.

* Show ALL necessary construction.

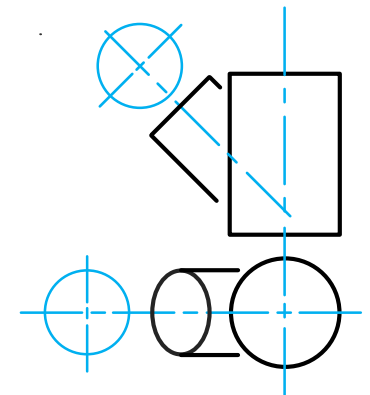

Interpenetrations

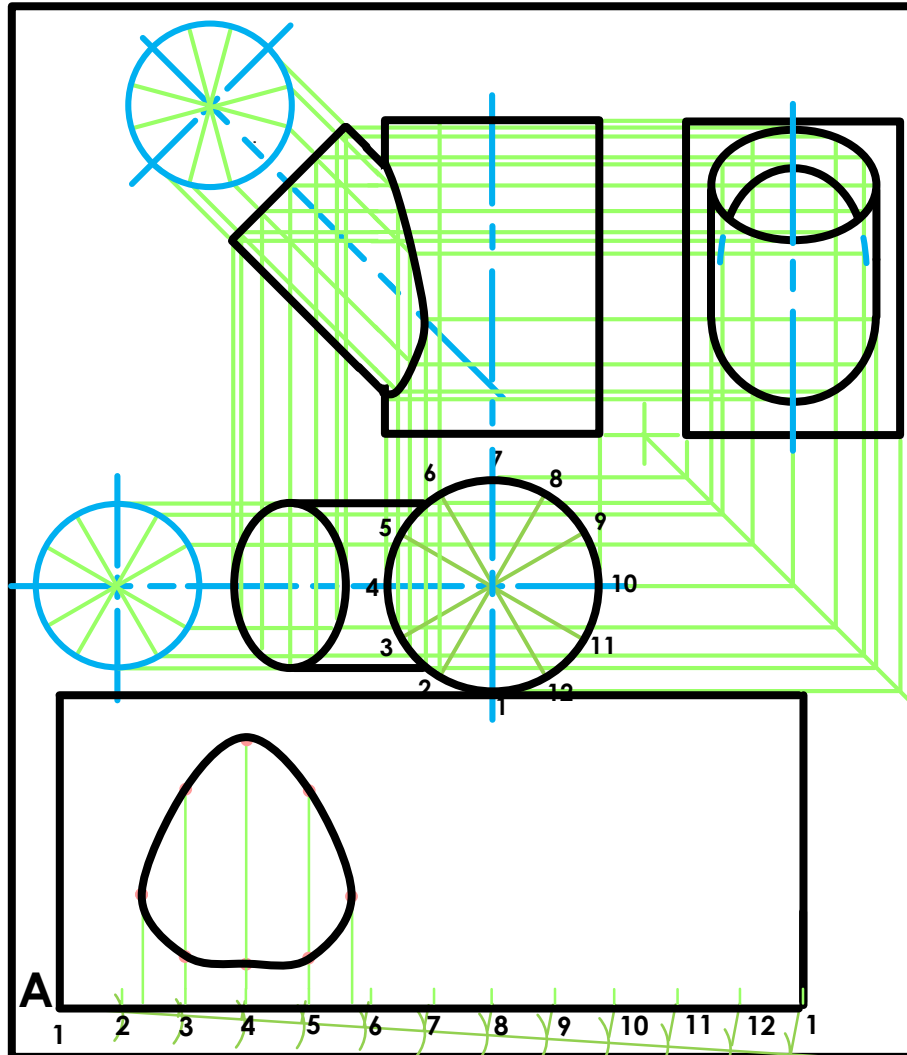
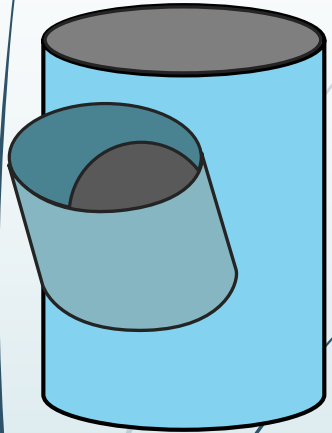

$$\begin{aligned}
 A &= 2\pi r \\
 &= 2 \times 3,141592654 \times 25 \\
 &= 157 \text{ mm} \\
 &= \frac{157}{12} \\
 &= 13
 \end{aligned}$$

Question 2: Interpenetration

Given:

- * The incomplete front view and top view of a cylinder of 45° that has to fit around another cylinder. The axes of both cylinders lie in a common vertical plane.
- * Auxiliary view of the branch cylinder.

Instructions:

Draw, to scale 1:1, the following:

1. The given top view.
2. The complete front view clearly showing the curve of interpenetration.
3. The complete left view.

* Show ALL hidden detail.

* Show ALL necessary construction.

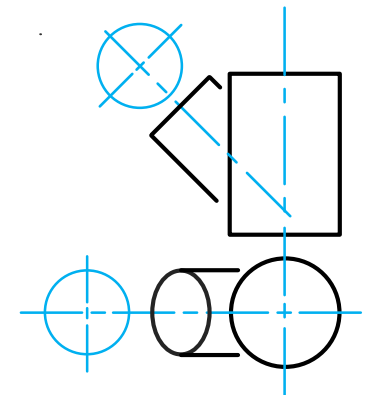

Interpenetrations

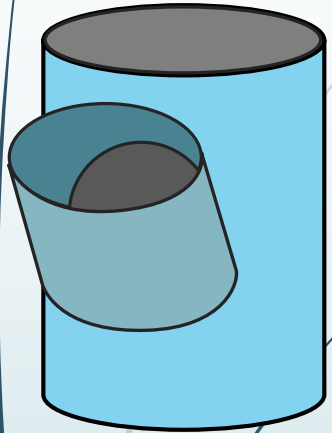

Question 2: Interpenetration

Given:

- * The incomplete front view and top view of a cylinder at 45° that has to fit around another cylinder. The axes of both cylinders lie in a common vertical plane.
- * Auxiliary view of the branch cylinder.

Instructions:

Draw, to scale 1:1, the following:

1. The given top view.
2. The complete front view clearly showing the curve of interpenetration.
3. The complete left view.
3. Develop the main cylinder and to show the interpenetration clearly.

4. Develop the branch cylinder.

- * Show ALL hidden detail.
- * Show ALL necessary construction.

Question 2: Interpenetration

Given:

- * The incomplete front view and top view of a cylinder at 45° that has to fit around another cylinder. The axes of both cylinders lie in a common vertical plane.
- * Auxiliary view of the branch cylinder.

Instructions:

Draw, to scale 1:1, the following:

1. The given top view.
2. The complete front view clearly showing the curve of interpenetration.
2. The complete left view.
3. Develop the main cylinder and to show the interpenetration clearly. Develop the branch cylinder.

* Show ALL hidden detail.

* Show ALL necessary construction.

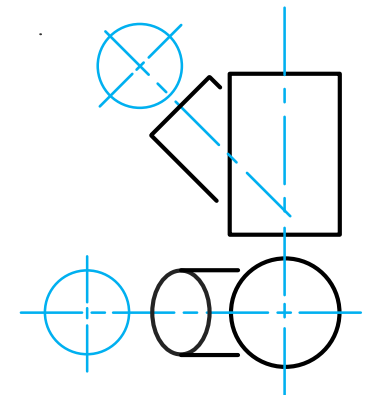

Interpenetrations

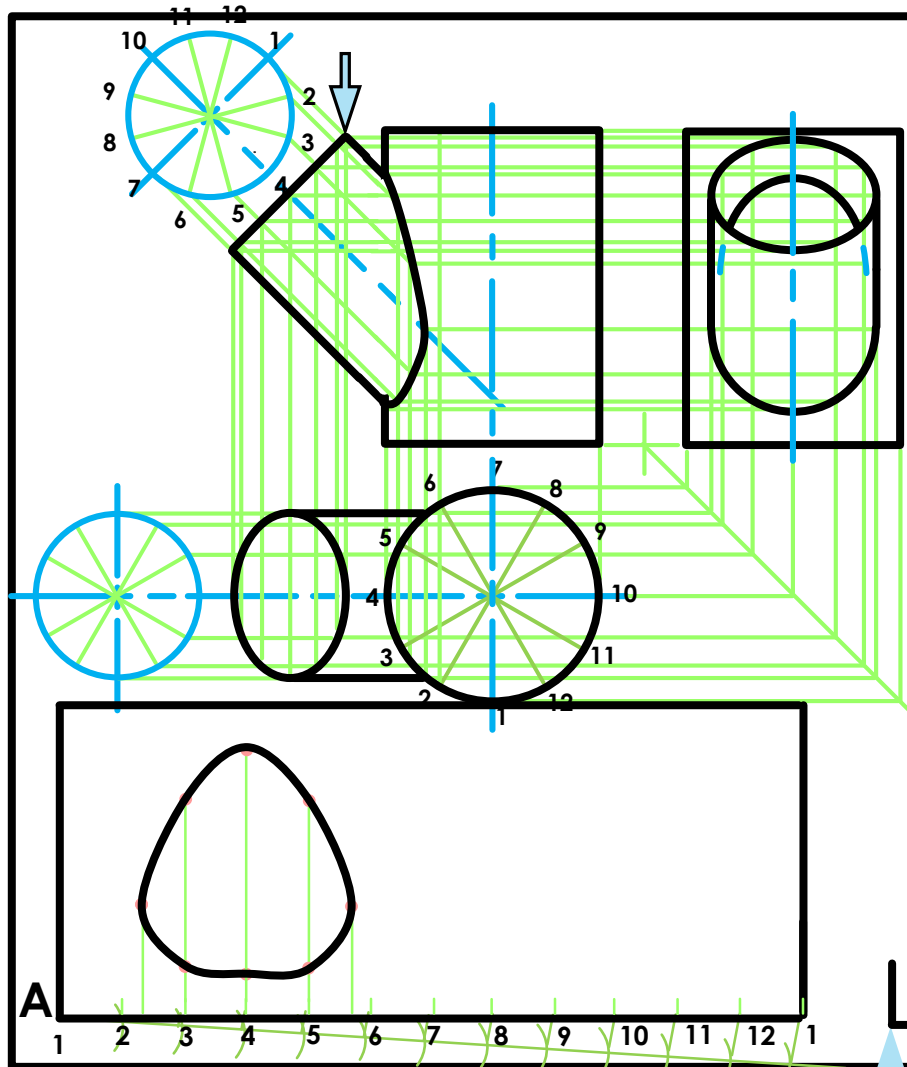
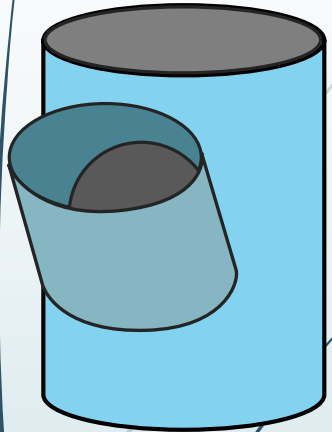

$$\begin{aligned}
 A &= 2\pi r \\
 &= 2 \times 3,141592654 \times 25 \\
 &= 157 \text{ mm} \\
 &= \frac{157}{12} \\
 &= 13
 \end{aligned}$$

$$\begin{aligned}
 B &= 2\pi r \\
 &= 2 \times 3,141592654 \times 20 \\
 &= 126 \text{ mm}
 \end{aligned}$$

Question 2: Interpenetration

Given:

- * The incomplete front view and top view of a cylinder of 45° that has to fit around another cylinder. The axes of both cylinders lie in a common vertical plane.
- * Auxiliary view of the branch cylinder.

Instructions:

Draw, to scale 1:1, the following:

1. The given top view.
2. The complete front view clearly showing the curve of interpenetration.
3. The complete left view.

* Show ALL hidden detail.

* Show ALL necessary construction.

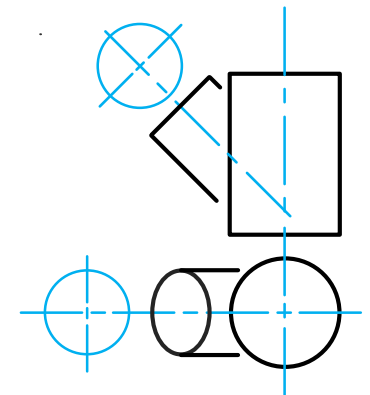

Interpenetrations

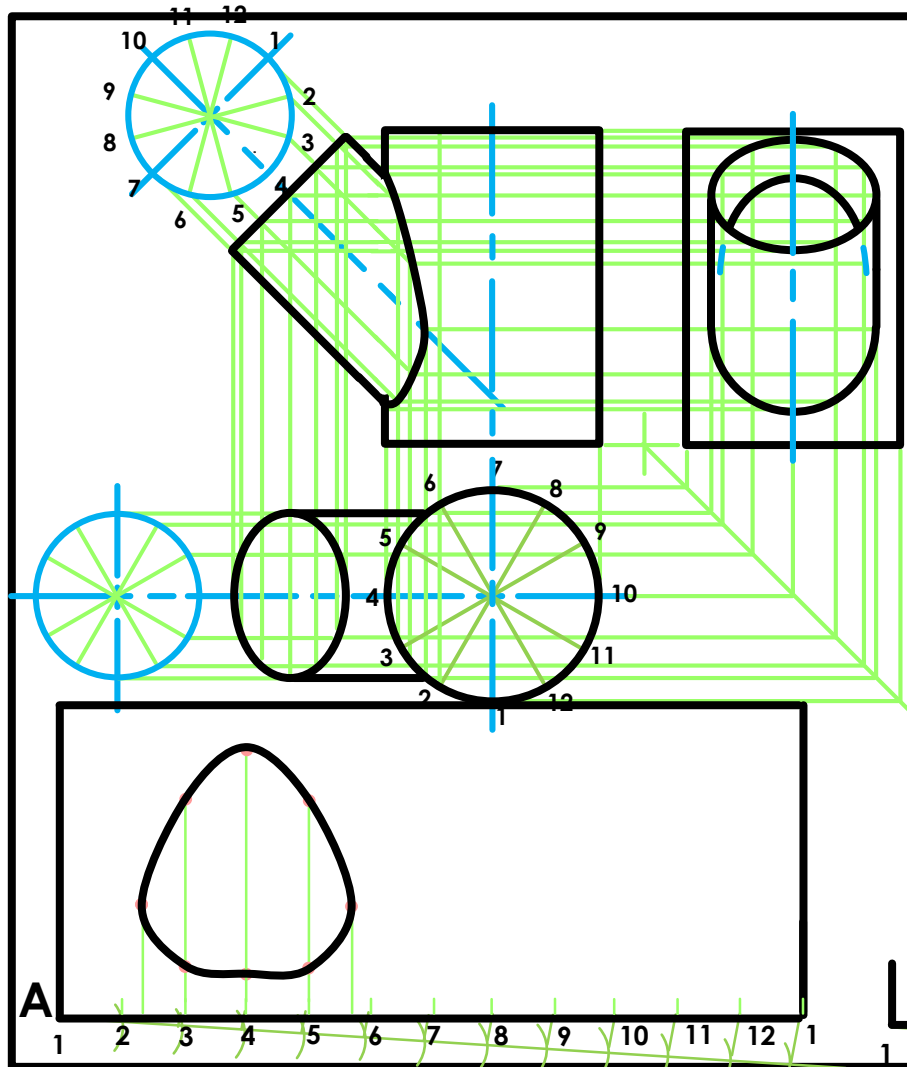
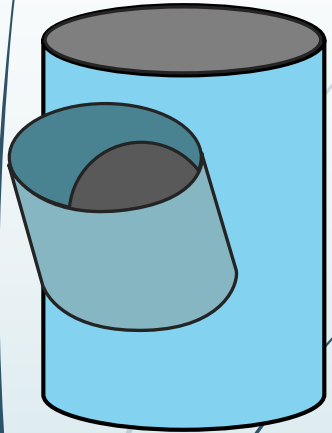

$$\begin{aligned}
 A &= 2\pi r \\
 &= 2 \times 3,141592654 \times 25 \\
 &= 157 \text{ mm} \\
 &= \frac{157}{12} \\
 &= 13
 \end{aligned}$$

$$\begin{aligned}
 B &= 2\pi r \\
 &= 2 \times 3,141592654 \times 20 \\
 &= 126 \text{ mm} \\
 &= \frac{126}{12} \\
 &= 11
 \end{aligned}$$

Question 2: Interpenetration

Given:

- * The incomplete front view and top view of a cylinder at 45° that has to fit around another cylinder. The axes of both cylinders lie in a common vertical plane.
- * Auxiliary view of the branch cylinder.

Instructions:

Draw, to scale 1:1, the following:

1. The given top view.
2. The complete front view clearly showing the curve of interpenetration.
3. The complete left view.

* Show ALL hidden detail.

* Show ALL necessary construction.

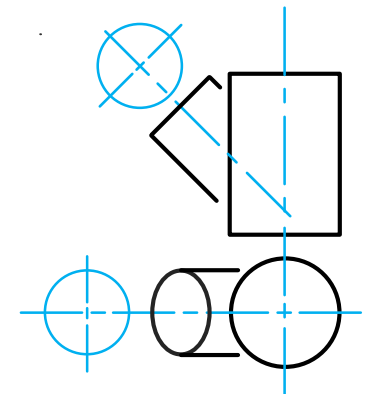

Interpenetrations

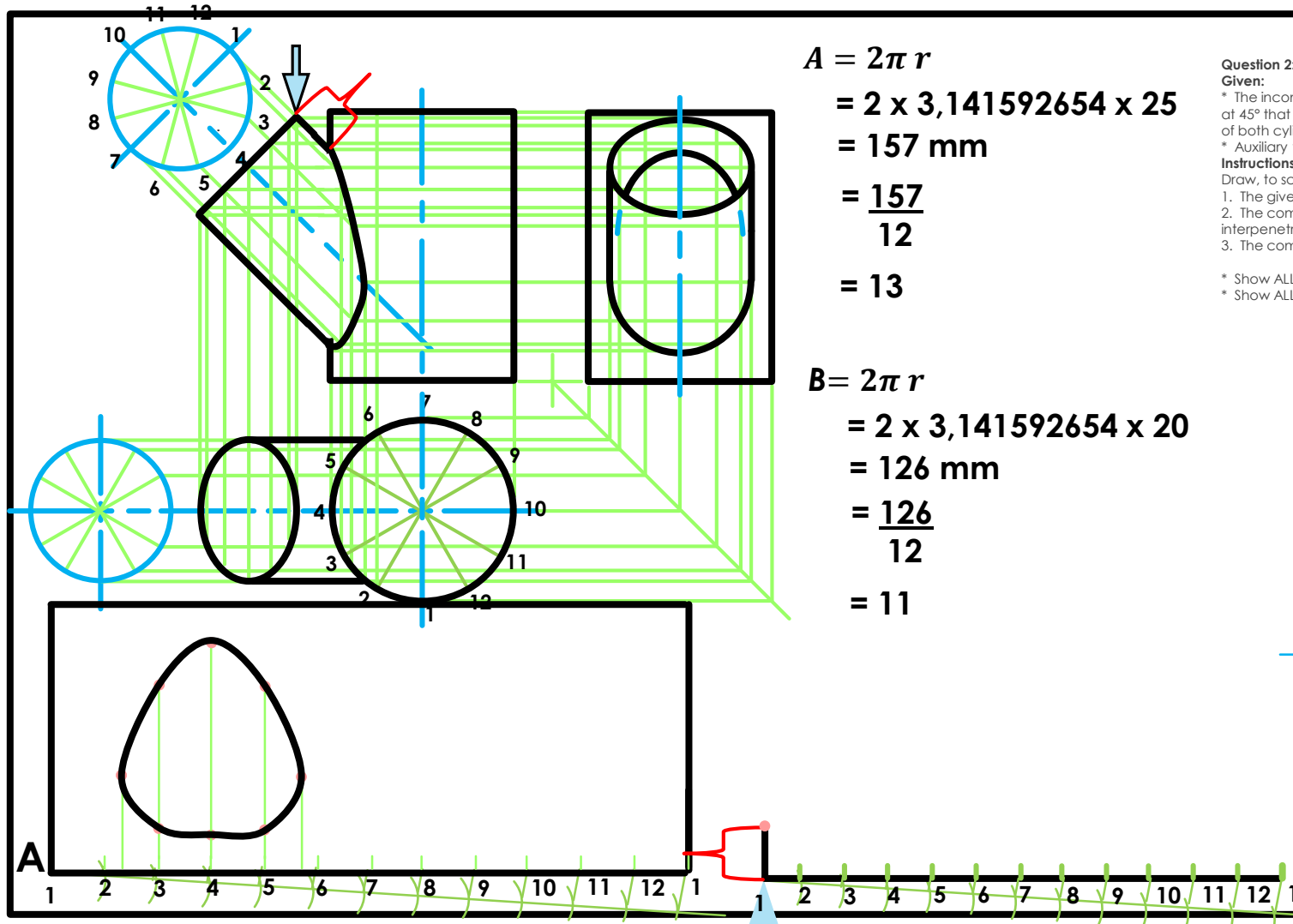
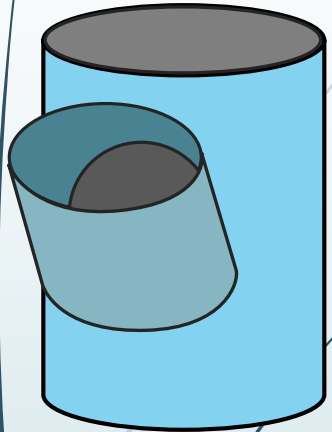

$$\begin{aligned}
 A &= 2\pi r \\
 &= 2 \times 3,141592654 \times 25 \\
 &= 157 \text{ mm} \\
 &= \frac{157}{12} \\
 &= 13
 \end{aligned}$$

$$\begin{aligned}
 B &= 2\pi r \\
 &= 2 \times 3,141592654 \times 20 \\
 &= 126 \text{ mm} \\
 &= \frac{126}{12} \\
 &= 11
 \end{aligned}$$

Question 2: Interpenetration

Given:

- * The incomplete front view and top view of a cylinder at 45° that has to fit around another cylinder. The axes of both cylinders lie in a common vertical plane.
- * Auxiliary view of the branch cylinder.

Instructions:

Draw, to scale 1:1, the following:

1. The given top view.
2. The complete front view clearly showing the curve of interpenetration.
3. The complete left view.

* Show ALL hidden detail.

* Show ALL necessary construction.

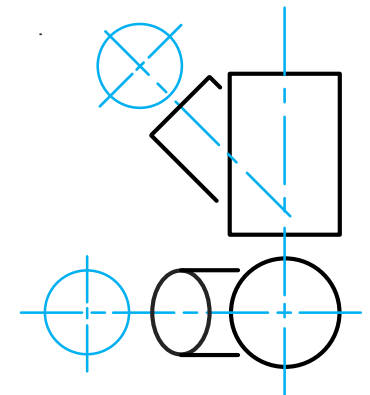

Interpenetrations

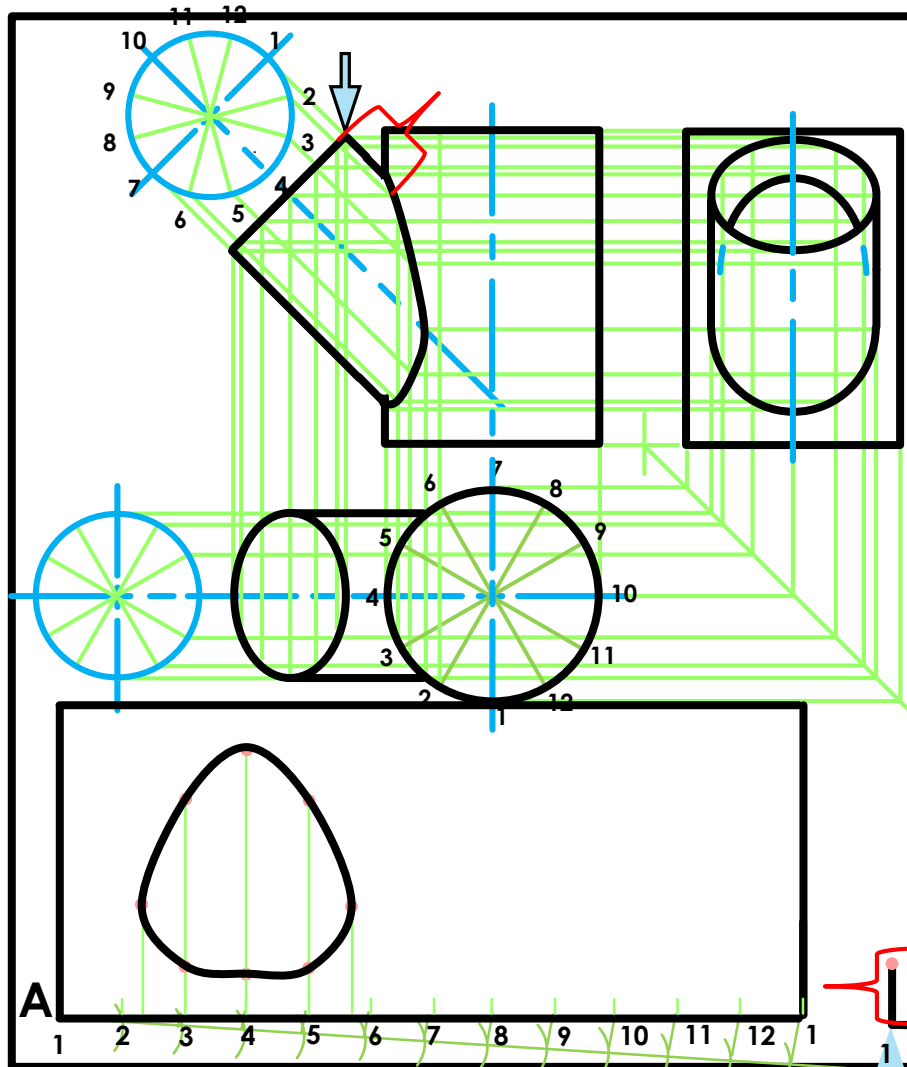
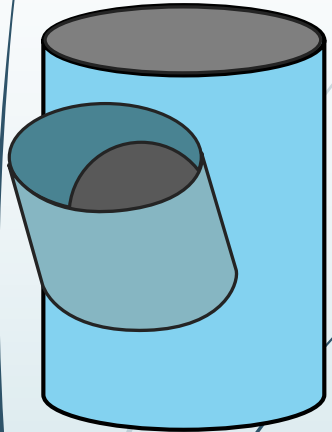

$$\begin{aligned}
 A &= 2\pi r \\
 &= 2 \times 3,141592654 \times 25 \\
 &= 157 \text{ mm} \\
 &= \frac{157}{12} \\
 &= 13
 \end{aligned}$$

$$\begin{aligned}
 B &= 2\pi r \\
 &= 2 \times 3,141592654 \times 20 \\
 &= 126 \text{ mm} \\
 &= \frac{126}{12} \\
 &= 11
 \end{aligned}$$

Question 2: Interpenetration

Given:

- * The incomplete front view and top view of a cylinder at 45° that has to fit around another cylinder. The axes of both cylinders lie in a common vertical plane.
- * Auxiliary view of the branch cylinder.

Instructions:

Draw, to scale 1:1, the following:

1. The given top view.
2. The complete front view clearly showing the curve of interpenetration.
3. The complete left view.

* Show ALL hidden detail.

* Show ALL necessary construction.

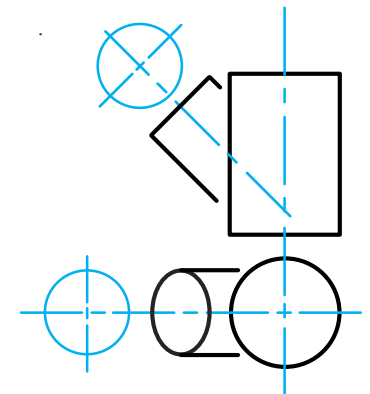

Interpenetrations

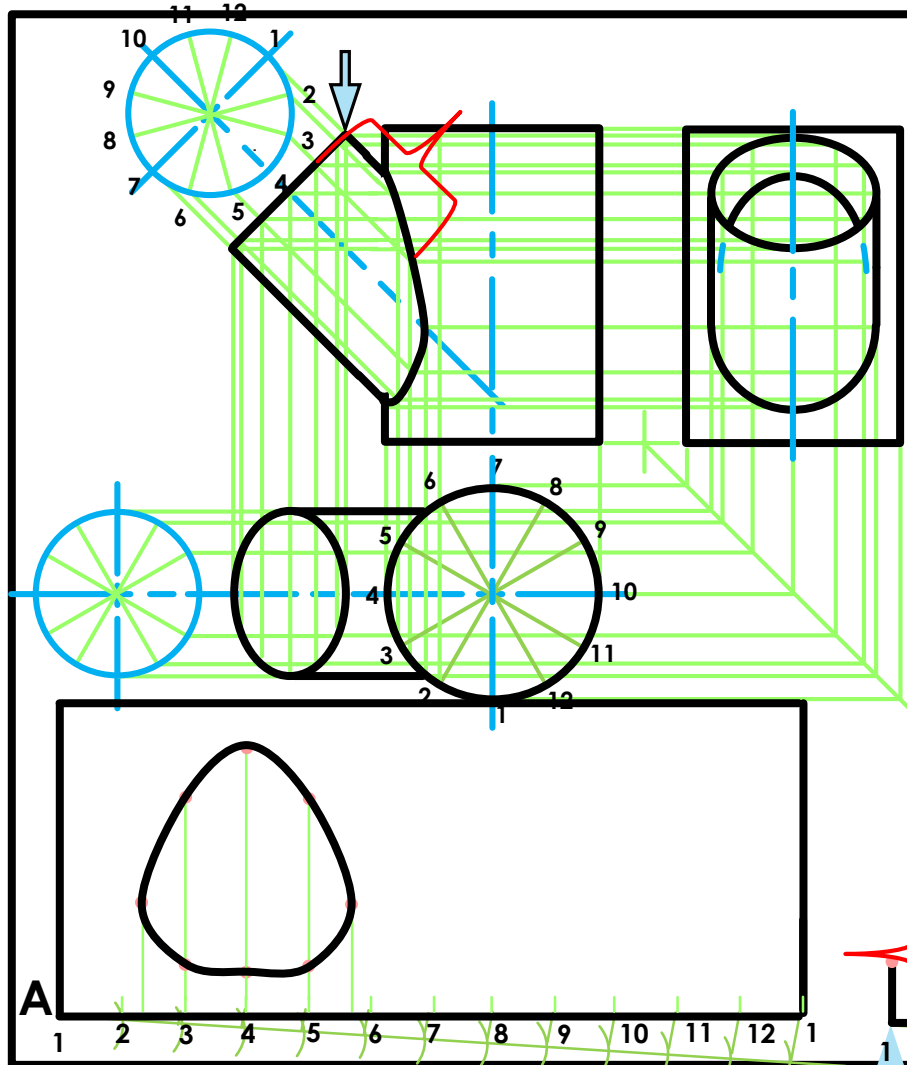
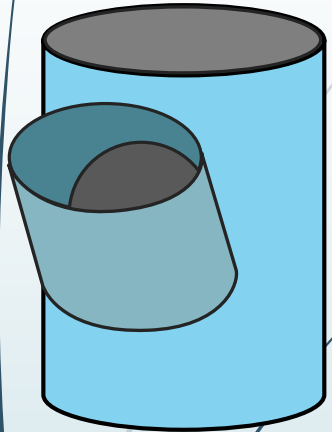

$$\begin{aligned}
 A &= 2\pi r \\
 &= 2 \times 3,141592654 \times 25 \\
 &= 157 \text{ mm} \\
 &= \frac{157}{12} \\
 &= 13
 \end{aligned}$$

$$\begin{aligned}
 B &= 2\pi r \\
 &= 2 \times 3,141592654 \times 20 \\
 &= 126 \text{ mm} \\
 &= \frac{126}{12} \\
 &= 11
 \end{aligned}$$

Question 2: Interpenetration

Given:

- * The incomplete front view and top view of a cylinder at 45° that has to fit around another cylinder. The axes of both cylinders lie in a common vertical plane.
- * Auxiliary view of the branch cylinder.

Instructions:

Draw, to scale 1:1, the following:

1. The given top view.
2. The complete front view clearly showing the curve of interpenetration.
3. The complete left view.

* Show ALL hidden detail.

* Show ALL necessary construction.

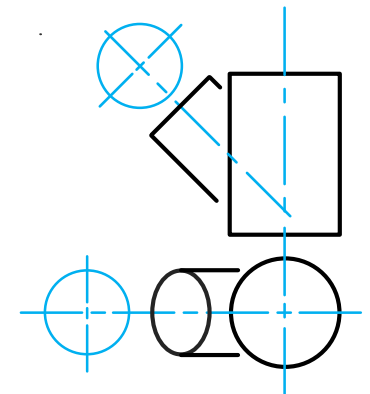

Interpenetrations

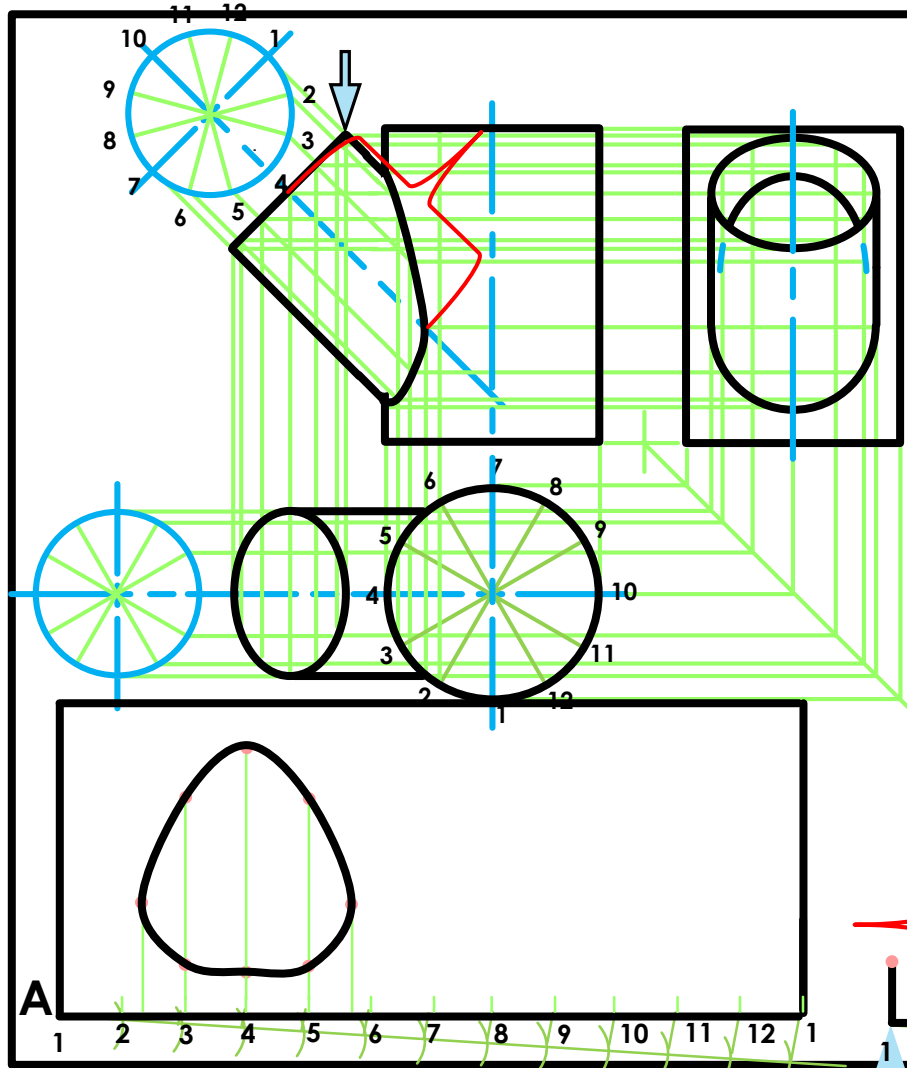
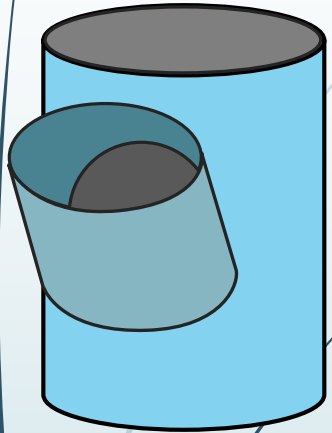

$$\begin{aligned}
 A &= 2\pi r \\
 &= 2 \times 3,141592654 \times 25 \\
 &= 157 \text{ mm} \\
 &= \frac{157}{12} \\
 &= 13
 \end{aligned}$$

$$\begin{aligned}
 B &= 2\pi r \\
 &= 2 \times 3,141592654 \times 20 \\
 &= 126 \text{ mm} \\
 &= \frac{126}{12} \\
 &= 11
 \end{aligned}$$

Question 2: Interpenetration

Given:

- * The incomplete front view and top view of a cylinder at 45° that has to fit around another cylinder. The axes of both cylinders lie in a common vertical plane.
- * Auxiliary view of the branch cylinder.

Instructions:

Draw, to scale 1:1, the following:

1. The given top view.
2. The complete front view clearly showing the curve of interpenetration.
3. The complete left view.

* Show ALL hidden detail.

* Show ALL necessary construction.

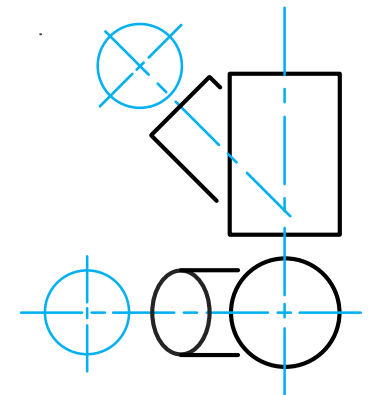

Interpenetrations

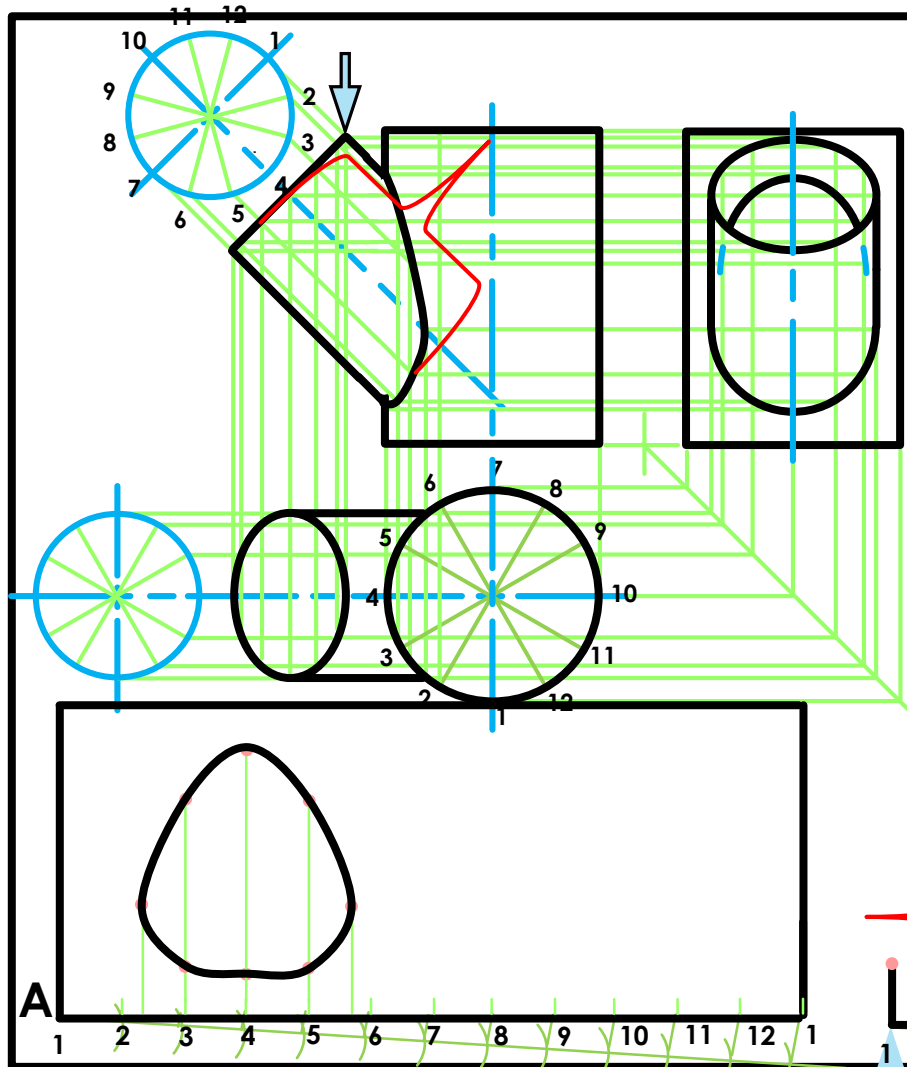
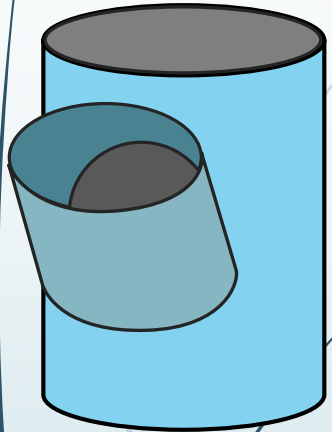

$$\begin{aligned}
 A &= 2\pi r \\
 &= 2 \times 3,141592654 \times 25 \\
 &= 157 \text{ mm} \\
 &= \frac{157}{12} \\
 &= 13
 \end{aligned}$$

$$\begin{aligned}
 B &= 2\pi r \\
 &= 2 \times 3,141592654 \times 20 \\
 &= 126 \text{ mm} \\
 &= \frac{126}{12} \\
 &= 11
 \end{aligned}$$

Question 2: Interpenetration

Given:

- * The incomplete front view and top view of a cylinder at 45° that has to fit around another cylinder. The axes of both cylinders lie in a common vertical plane.
- * Auxiliary view of the branch cylinder.

Instructions:

Draw, to scale 1:1, the following:

1. The given top view.
2. The complete front view clearly showing the curve of interpenetration.
3. The complete left view.

* Show ALL hidden detail.

* Show ALL necessary construction.

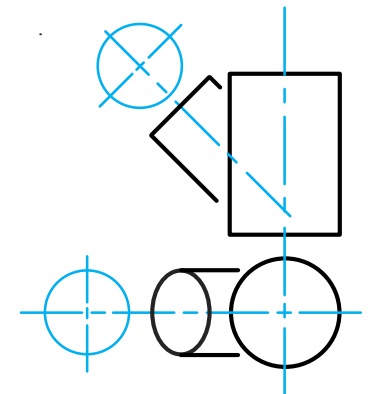

Interpenetrations

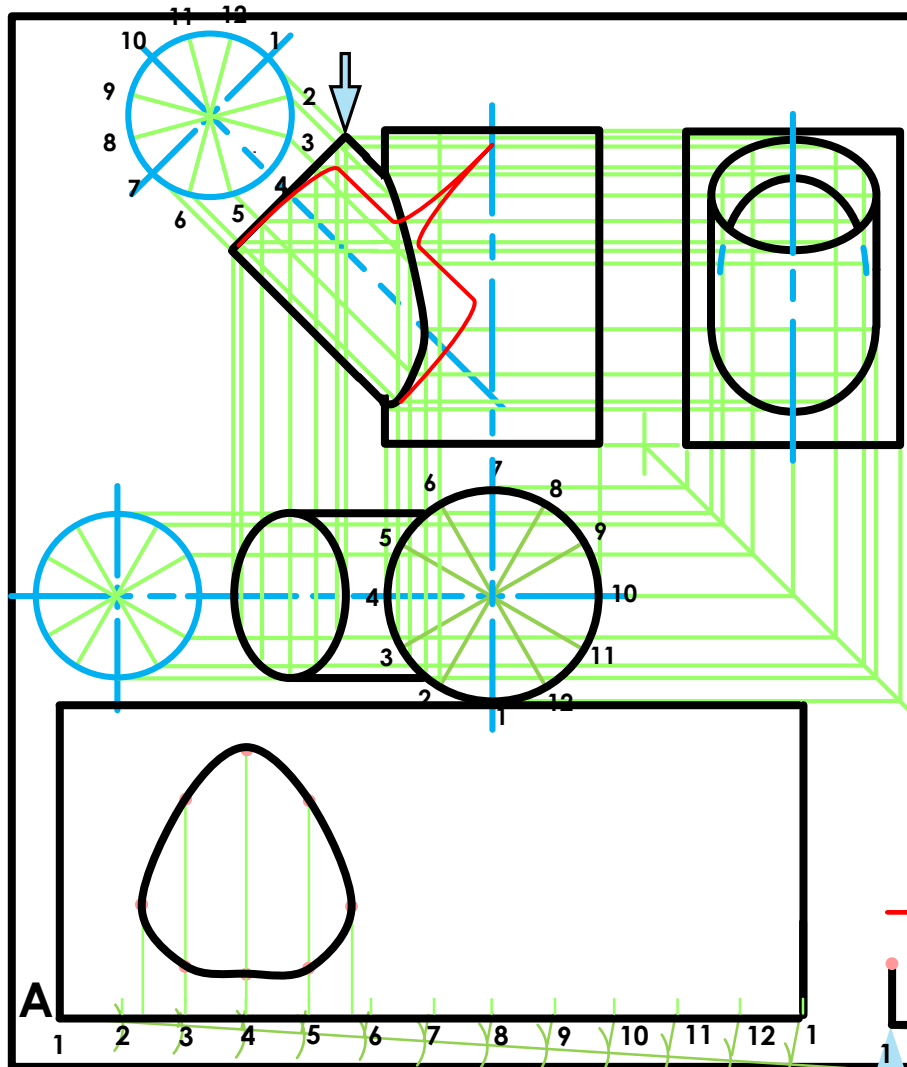
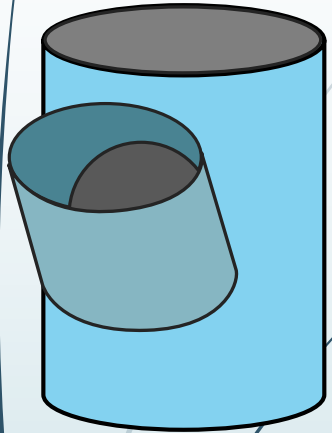

$$\begin{aligned}
 A &= 2\pi r \\
 &= 2 \times 3,141592654 \times 25 \\
 &= 157 \text{ mm} \\
 &= \frac{157}{12} \\
 &= 13
 \end{aligned}$$

$$\begin{aligned}
 B &= 2\pi r \\
 &= 2 \times 3,141592654 \times 20 \\
 &= 126 \text{ mm} \\
 &= \frac{126}{12} \\
 &= 11
 \end{aligned}$$

Question 2: Interpenetration

Given:

- * The incomplete front view and top view of a cylinder at 45° that has to fit around another cylinder. The axes of both cylinders lie in a common vertical plane.
- * Auxiliary view of the branch cylinder.

Instructions:

Draw, to scale 1:1, the following:

1. The given top view.
2. The complete front view clearly showing the curve of interpenetration.
3. The complete left view.

* Show ALL hidden detail.

* Show ALL necessary construction.

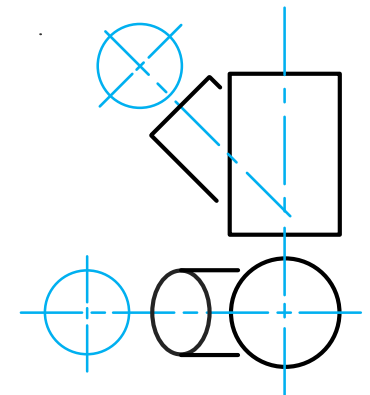

Interpenetrations

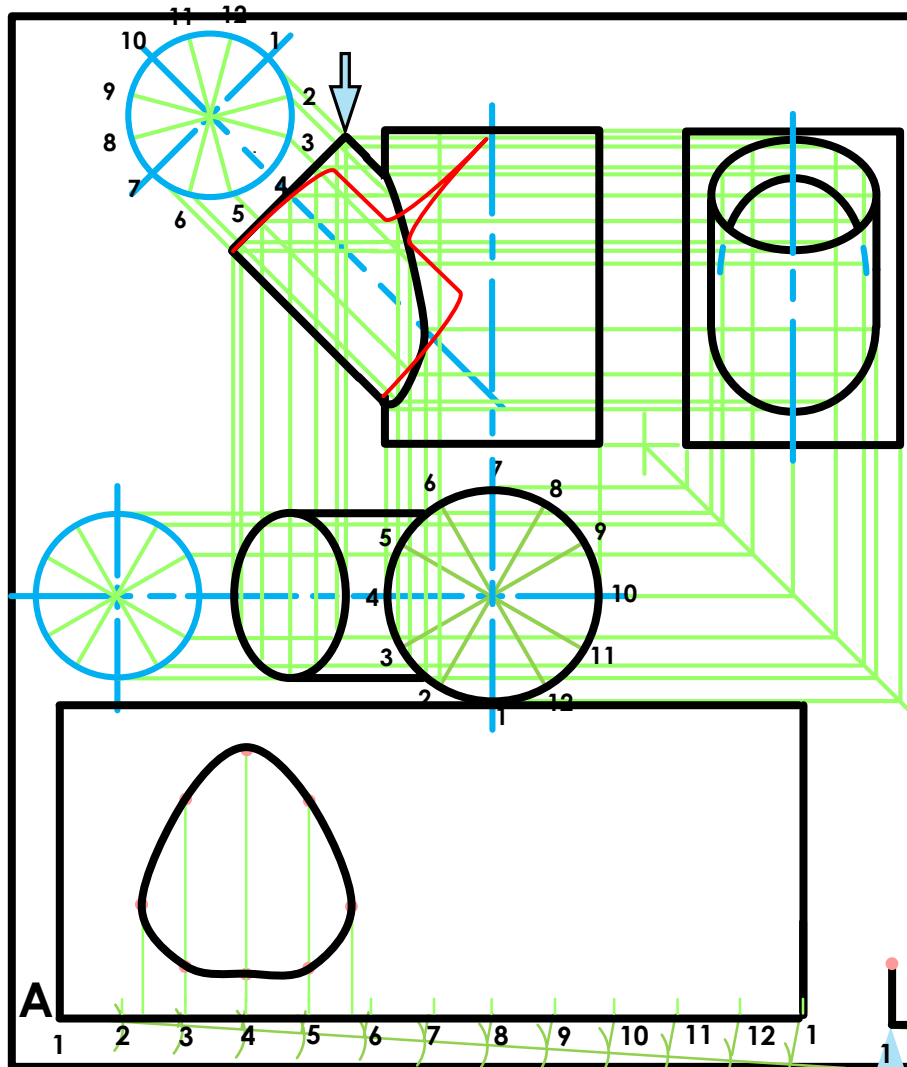
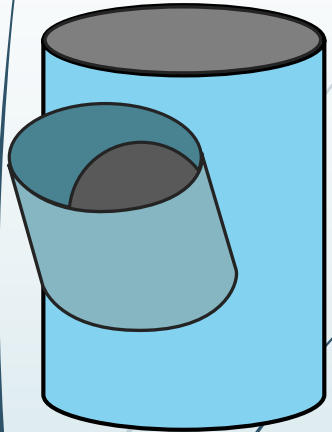

$$\begin{aligned}
 A &= 2\pi r \\
 &= 2 \times 3,141592654 \times 25 \\
 &= 157 \text{ mm} \\
 &= \frac{157}{12} \\
 &= 13
 \end{aligned}$$

$$\begin{aligned}
 B &= 2\pi r \\
 &= 2 \times 3,141592654 \times 20 \\
 &= 126 \text{ mm} \\
 &= \frac{126}{12} \\
 &= 11
 \end{aligned}$$

Question 2: Interpenetration

Given:

- * The incomplete front view and top view of a cylinder at 45° that has to fit around another cylinder. The axes of both cylinders lie in a common vertical plane.
- * Auxiliary view of the branch cylinder.

Instructions:

Draw, to scale 1:1, the following:

1. The given top view.
2. The complete front view clearly showing the curve of interpenetration.
3. The complete left view.

* Show ALL hidden detail.

* Show ALL necessary construction.

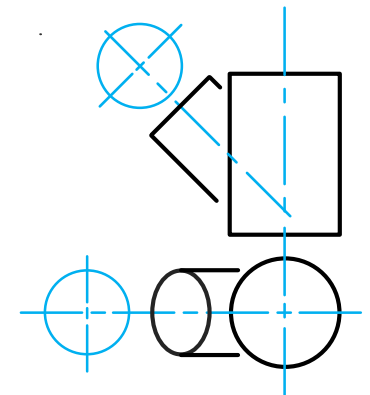

Interpenetrations

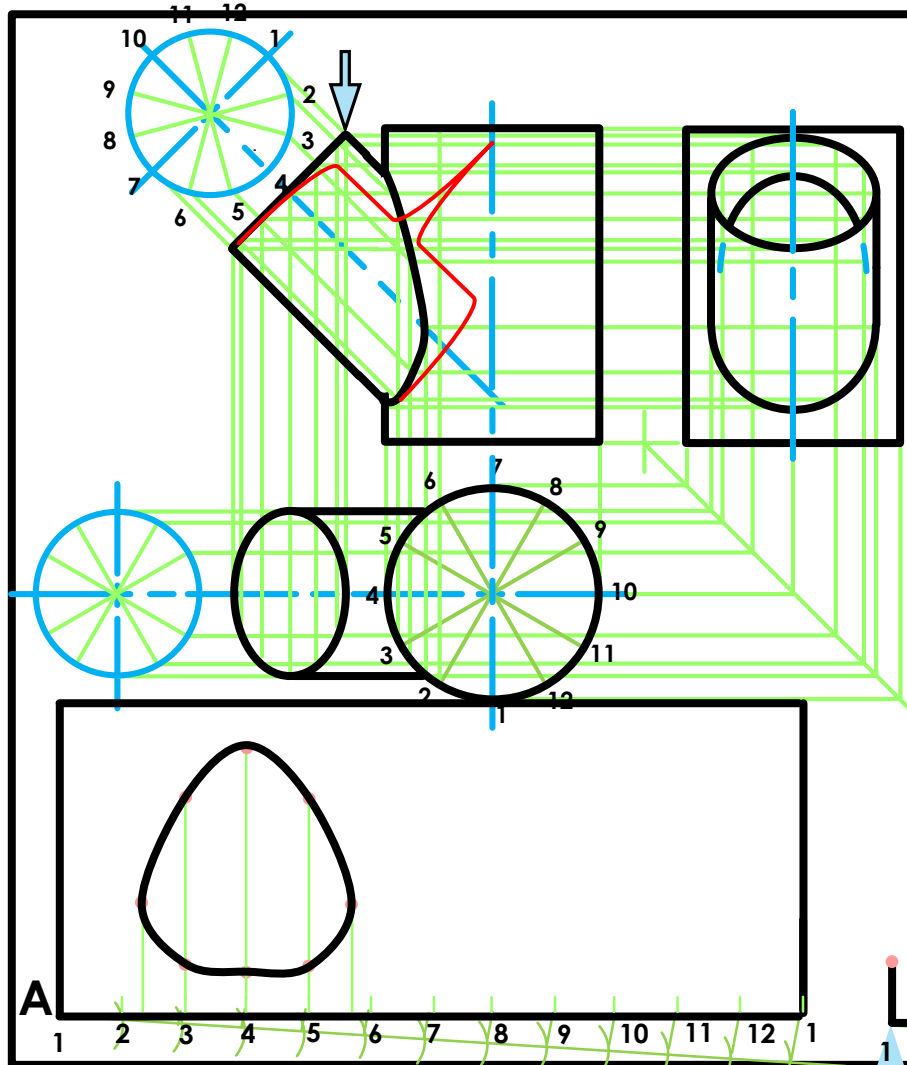
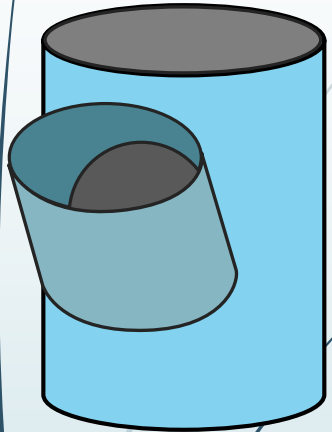

$$\begin{aligned}
 A &= 2\pi r \\
 &= 2 \times 3,141592654 \times 25 \\
 &= 157 \text{ mm} \\
 &= \frac{157}{12} \\
 &= 13
 \end{aligned}$$

$$\begin{aligned}
 B &= 2\pi r \\
 &= 2 \times 3,141592654 \times 20 \\
 &= 126 \text{ mm} \\
 &= \frac{126}{12} \\
 &= 11
 \end{aligned}$$

Question 2: Interpenetration

Given:

- * The incomplete front view and top view of a cylinder at 45° that has to fit around another cylinder. The axes of both cylinders lie in a common vertical plane.
- * Auxiliary view of the branch cylinder.

Instructions:

Draw, to scale 1:1, the following:

1. The given top view.
2. The complete front view clearly showing the curve of interpenetration.
3. The complete left view.

* Show ALL hidden detail.

* Show ALL necessary construction.

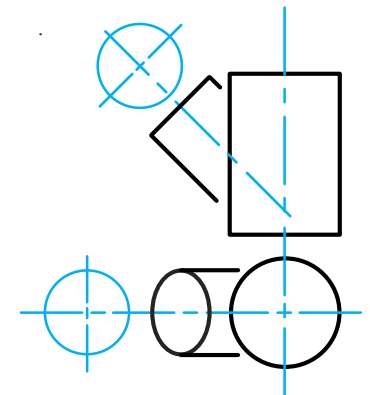

Interpenetrations

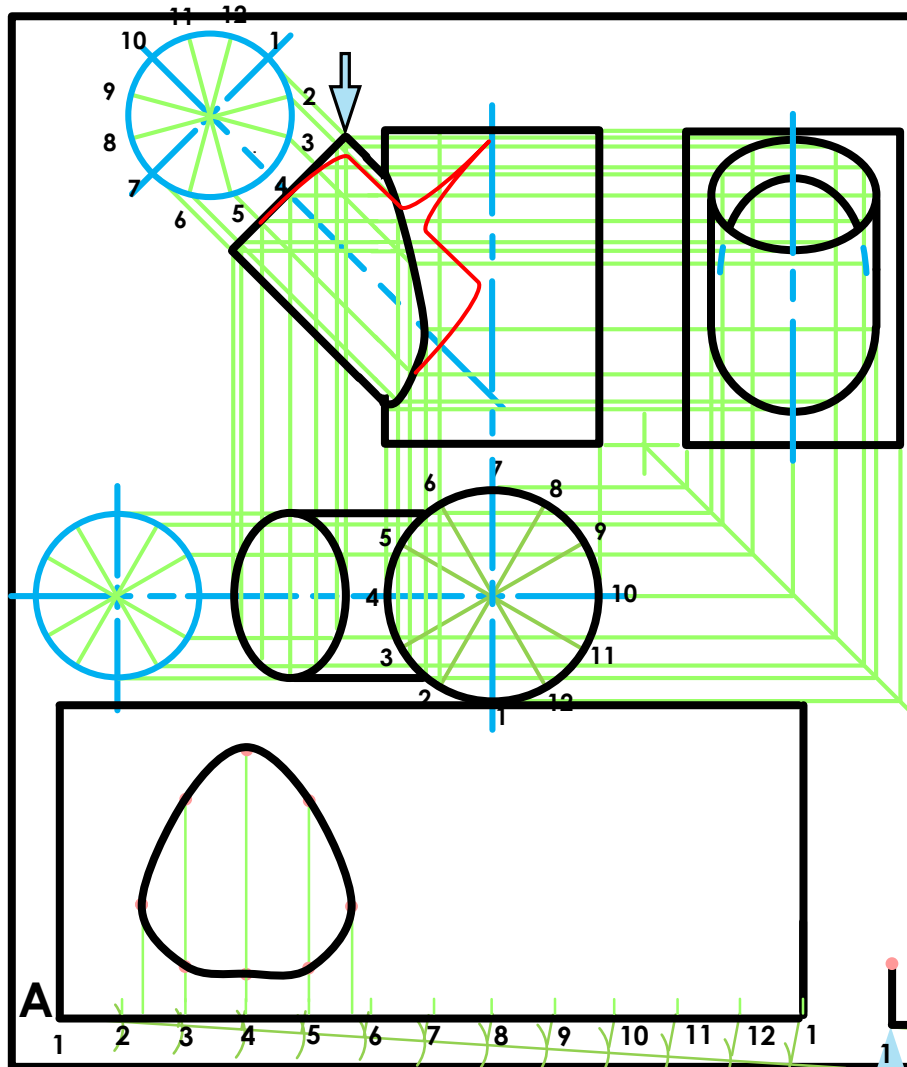
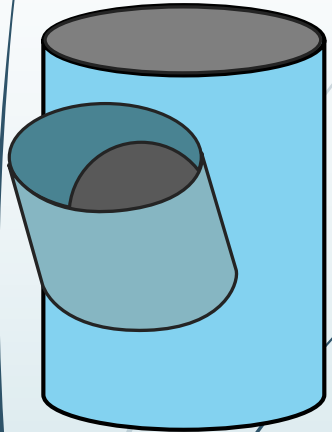

$$\begin{aligned}
 A &= 2\pi r \\
 &= 2 \times 3,141592654 \times 25 \\
 &= 157 \text{ mm} \\
 &= \frac{157}{12} \\
 &= 13
 \end{aligned}$$

$$\begin{aligned}
 B &= 2\pi r \\
 &= 2 \times 3,141592654 \times 20 \\
 &= 126 \text{ mm} \\
 &= \frac{126}{12} \\
 &= 11
 \end{aligned}$$

Question 2: Interpenetration

Given:

- * The incomplete front view and top view of a cylinder at 45° that has to fit around another cylinder. The axes of both cylinders lie in a common vertical plane.
- * Auxiliary view of the branch cylinder.

Instructions:

Draw, to scale 1:1, the following:

1. The given top view.
2. The complete front view clearly showing the curve of interpenetration.
3. The complete left view.

* Show ALL hidden detail.

* Show ALL necessary construction.

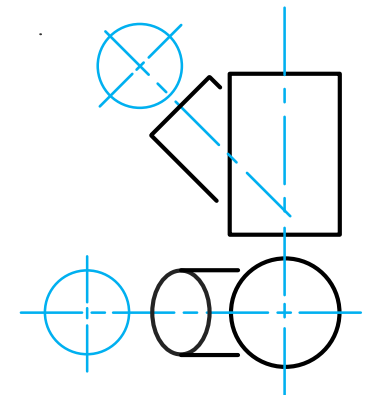

Interpenetrations

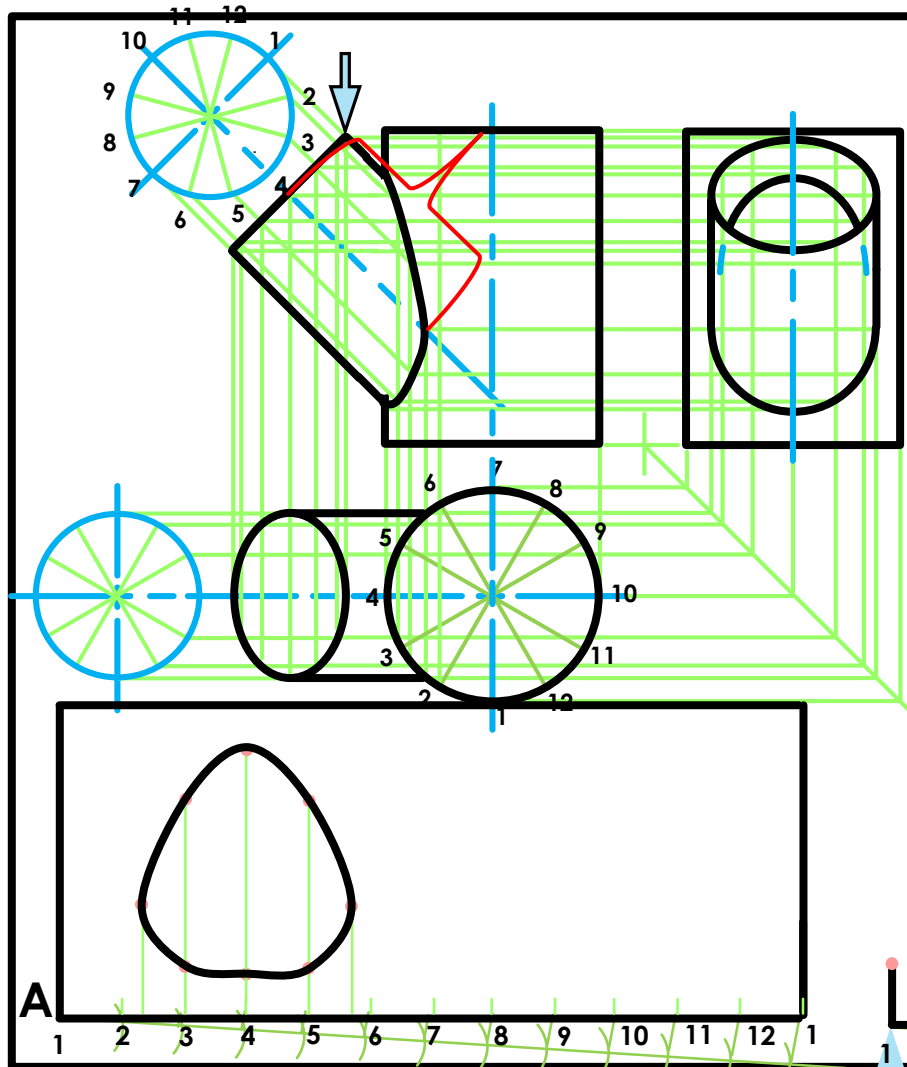
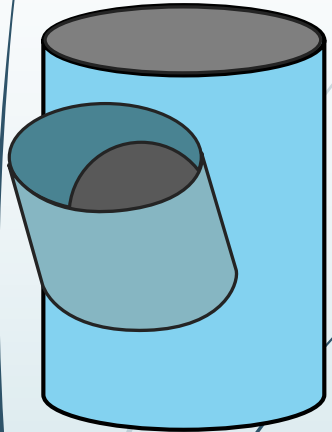

$$\begin{aligned}
 A &= 2\pi r \\
 &= 2 \times 3,141592654 \times 25 \\
 &= 157 \text{ mm} \\
 &= \frac{157}{12} \\
 &= 13
 \end{aligned}$$

$$\begin{aligned}
 B &= 2\pi r \\
 &= 2 \times 3,141592654 \times 20 \\
 &= 126 \text{ mm} \\
 &= \frac{126}{12} \\
 &= 11
 \end{aligned}$$

Question 2: Interpenetration

Given:

- * The incomplete front view and top view of a cylinder at 45° that has to fit around another cylinder. The axes of both cylinders lie in a common vertical plane.
- * Auxiliary view of the branch cylinder.

Instructions:

Draw, to scale 1:1, the following:

1. The given top view.
2. The complete front view clearly showing the curve of interpenetration.
3. The complete left view.

* Show ALL hidden detail.

* Show ALL necessary construction.

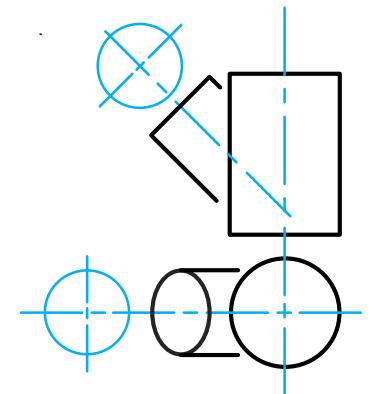

Interpenetrations

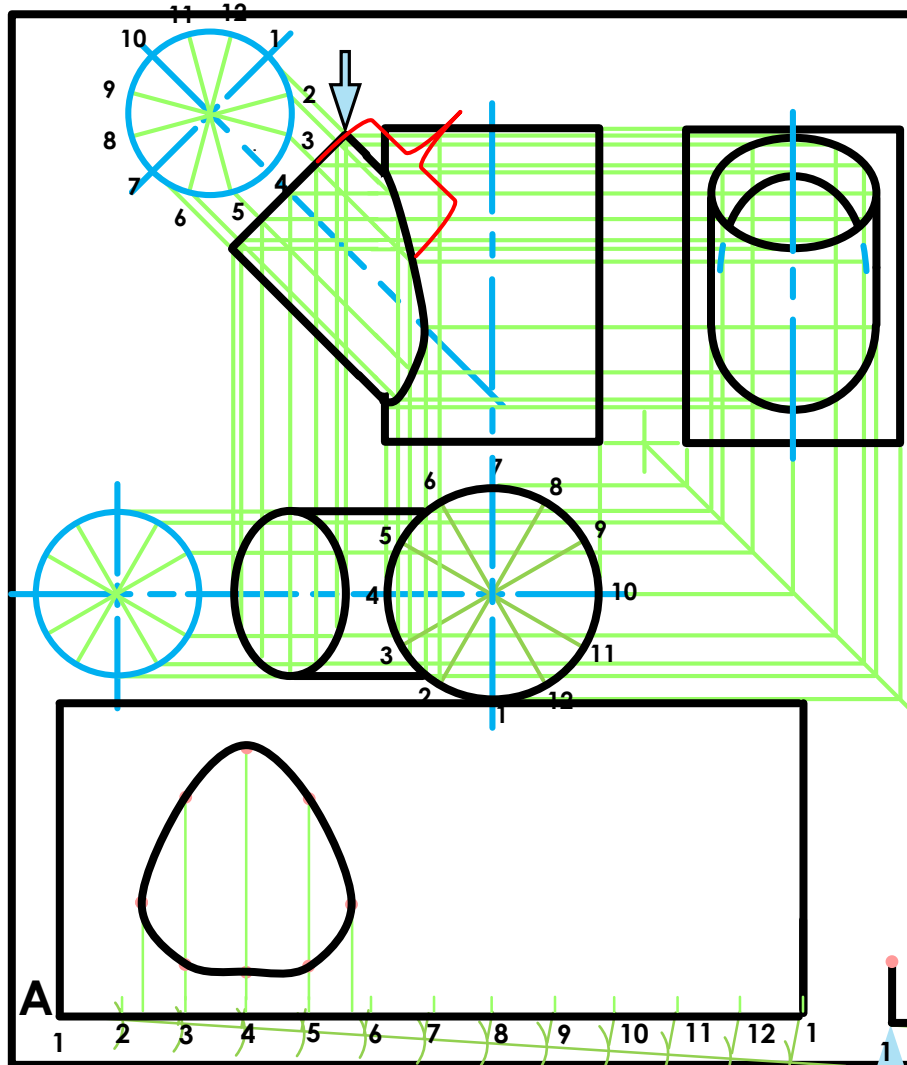
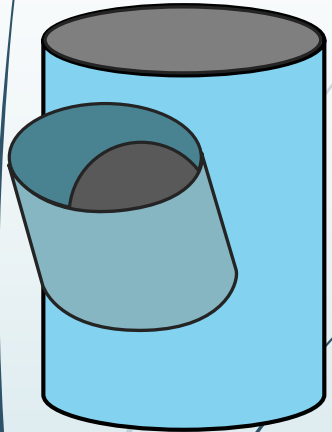

$$\begin{aligned}
 A &= 2\pi r \\
 &= 2 \times 3,141592654 \times 25 \\
 &= 157 \text{ mm} \\
 &= \frac{157}{12} \\
 &= 13
 \end{aligned}$$

$$\begin{aligned}
 B &= 2\pi r \\
 &= 2 \times 3,141592654 \times 20 \\
 &= 126 \text{ mm} \\
 &= \frac{126}{12} \\
 &= 11
 \end{aligned}$$

Question 2: Interpenetration

Given:

- * The incomplete front view and top view of a cylinder at 45° that has to fit around another cylinder. The axes of both cylinders lie in a common vertical plane.
- * Auxiliary view of the branch cylinder.

Instructions:

Draw, to scale 1:1, the following:

1. The given top view.
2. The complete front view clearly showing the curve of interpenetration.
3. The complete left view.

* Show ALL hidden detail.

* Show ALL necessary construction.

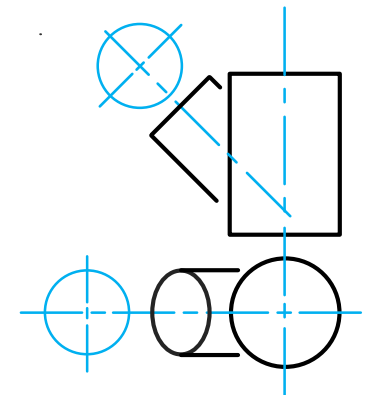

Interpenetrations

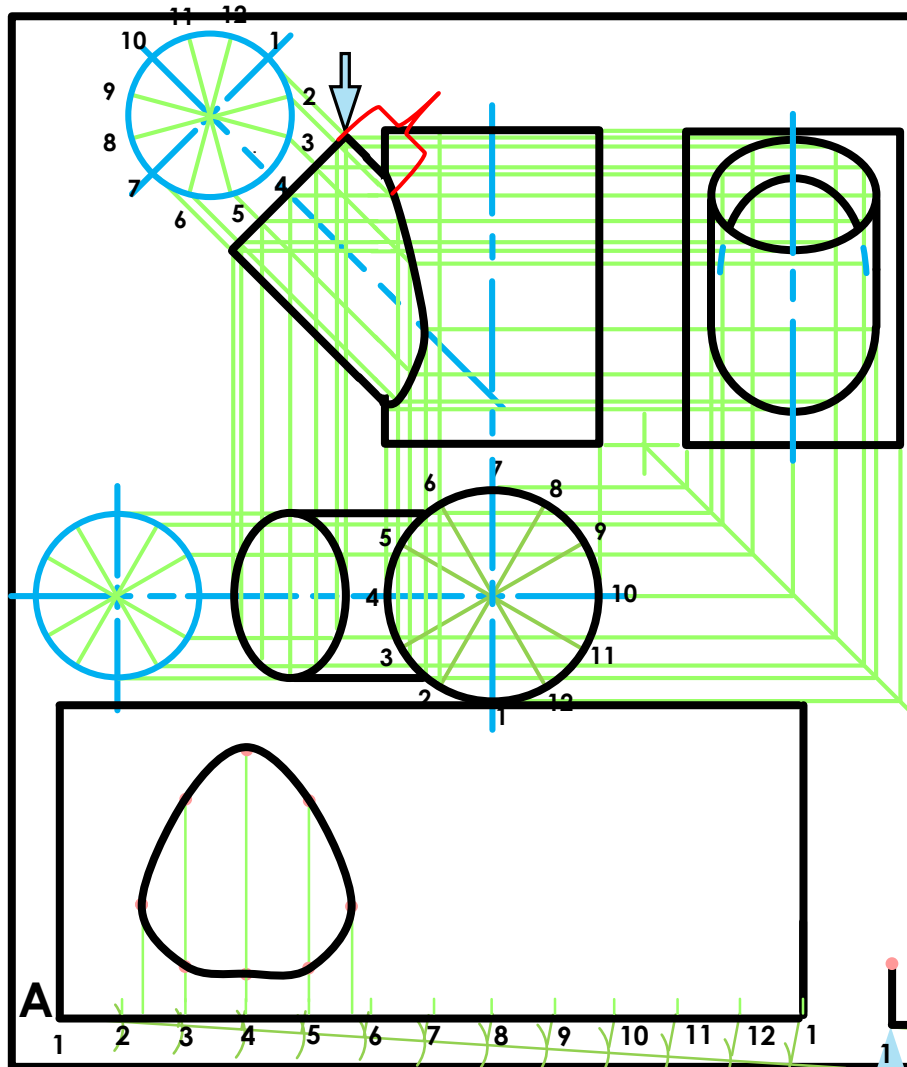
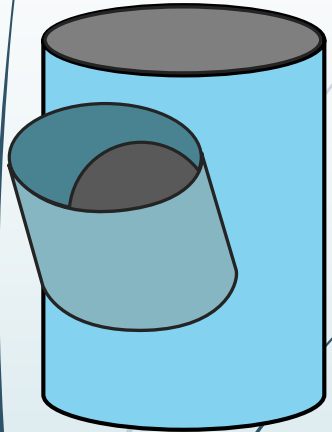

$$\begin{aligned}
 A &= 2\pi r \\
 &= 2 \times 3,141592654 \times 25 \\
 &= 157 \text{ mm} \\
 &= \frac{157}{12} \\
 &= 13
 \end{aligned}$$

$$\begin{aligned}
 B &= 2\pi r \\
 &= 2 \times 3,141592654 \times 20 \\
 &= 126 \text{ mm} \\
 &= \frac{126}{12} \\
 &= 11
 \end{aligned}$$

Question 2: Interpenetration

Given:

- * The incomplete front view and top view of a cylinder at 45° that has to fit around another cylinder. The axes of both cylinders lie in a common vertical plane.
- * Auxiliary view of the branch cylinder.

Instructions:

Draw, to scale 1:1, the following:

1. The given top view.
2. The complete front view clearly showing the curve of interpenetration.
3. The complete left view.

* Show ALL hidden detail.

* Show ALL necessary construction.

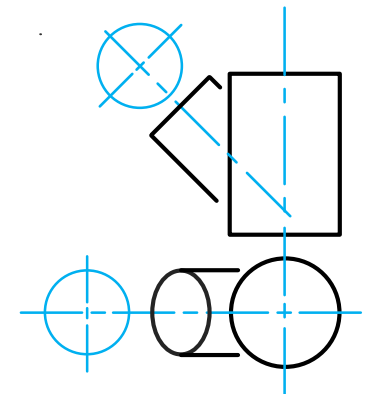

Interpenetrations

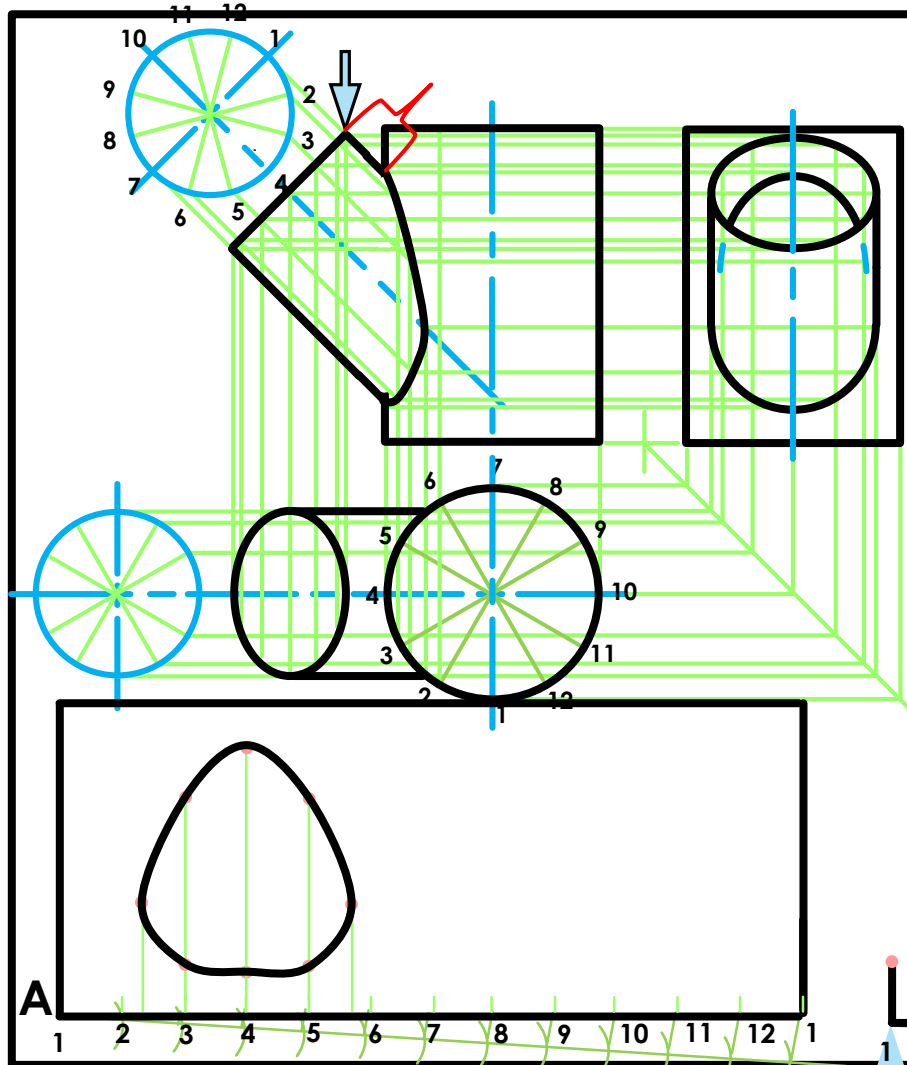
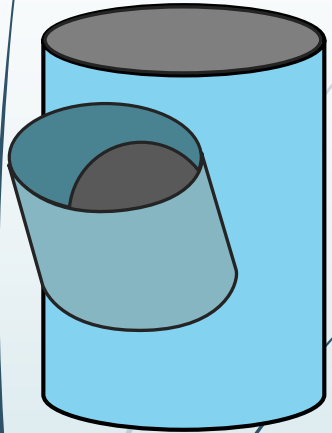

$$\begin{aligned}
 A &= 2\pi r \\
 &= 2 \times 3,141592654 \times 25 \\
 &= 157 \text{ mm} \\
 &= \frac{157}{12} \\
 &= 13
 \end{aligned}$$

$$\begin{aligned}
 B &= 2\pi r \\
 &= 2 \times 3,141592654 \times 20 \\
 &= 126 \text{ mm} \\
 &= \frac{126}{12} \\
 &= 11
 \end{aligned}$$

Question 2: Interpenetration

Given:

- * The incomplete front view and top view of a cylinder at 45° that has to fit around another cylinder. The axes of both cylinders lie in a common vertical plane.
- * Auxiliary view of the branch cylinder.

Instructions:

Draw, to scale 1:1, the following:

1. The given top view.
2. The complete front view clearly showing the curve of interpenetration.
3. The complete left view.

* Show ALL hidden detail.

* Show ALL necessary construction.

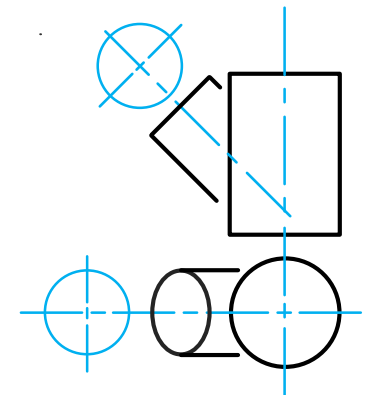

Interpenetrations

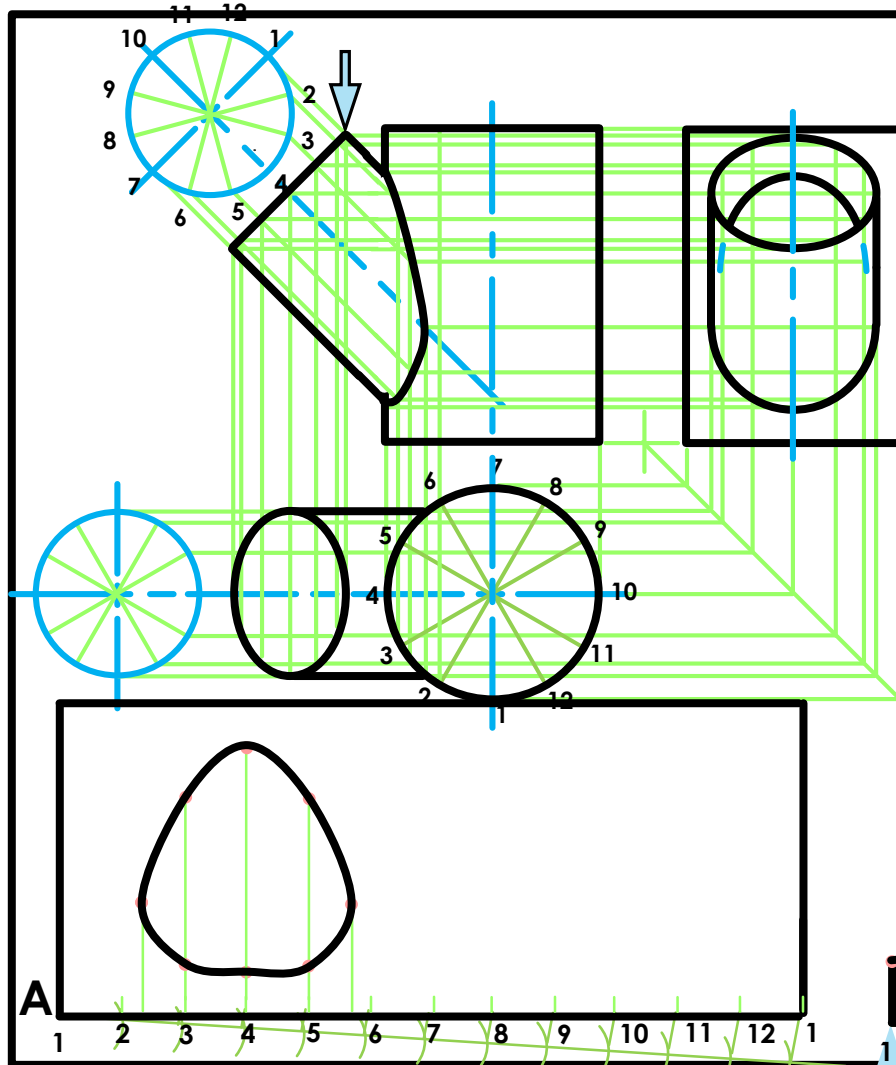
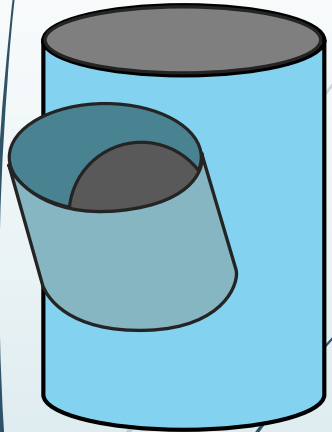

$$\begin{aligned}
 A &= 2\pi r \\
 &= 2 \times 3,141592654 \times 25 \\
 &= 157 \text{ mm} \\
 &= \frac{157}{12} \\
 &= 13
 \end{aligned}$$

$$\begin{aligned}
 B &= 2\pi r \\
 &= 2 \times 3,141592654 \times 20 \\
 &= 126 \text{ mm} \\
 &= \frac{126}{12} \\
 &= 11
 \end{aligned}$$

Question 2: Interpenetration

Given:

- * The incomplete front view and top view of a cylinder at 45° that has to fit around another cylinder. The axes of both cylinders lie in a common vertical plane.
- * Auxiliary view of the branch cylinder.

Instructions:

Draw, to scale 1:1, the following:

1. The given top view.
2. The complete front view clearly showing the curve of interpenetration.
3. The complete left view.

* Show ALL hidden detail.

* Show ALL necessary construction.

