



education

Department of Education
FREE STATE PROVINCE

PROVINCIAL PAPER

GRADE 11

ENGINEERING GRAPHICS AND DESIGN P2

TEST

SEPTEMBER 2018

MARKS: 50
TIME: 3 hours

This paper consists of 6 pages.

INSTRUCTIONS AND INFORMATION

1. This question paper consists of FOUR questions.
2. Answer ALL the questions.
3. ALL drawings are in third-angle-orthographic-projection, unless stated otherwise.
4. ALL drawings must be drawn to scale 1:1, unless stated otherwise.
5. ALL questions must be answered on the DIAGRAM SHEETS, as instructed.
6. ALL the pages must be restapled in numerical sequence, irrespective of whether the question was attempted or not.
7. Time management is essential in order to complete all the questions.
8. Print your name and surname as well as the grade in the space provided on each page.
9. ALL answers must be drawn accurately and neatly.
10. ALL necessary construction and projection lines must be shown.
11. Plan each drawing carefully from the given position, which is indicated on the diagram sheets.
12. Any details or dimensions not given must be assumed in good proportion.

FOR OFFICIAL USE ONLY				
QUESTION	MARKS OBTAINED	½	MODERATED	½
1				
2				
TOTAL				
	5	0	5	0

FINAL CONVERTED MARK	CHECKED BY
100	

NAME & SURNAME		GRADE	11	1
----------------	--	-------	----	---

STAPEL

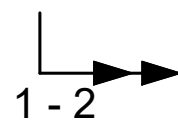
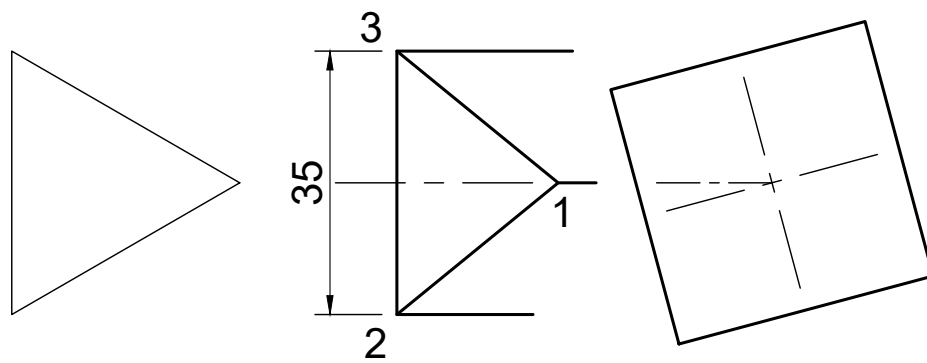
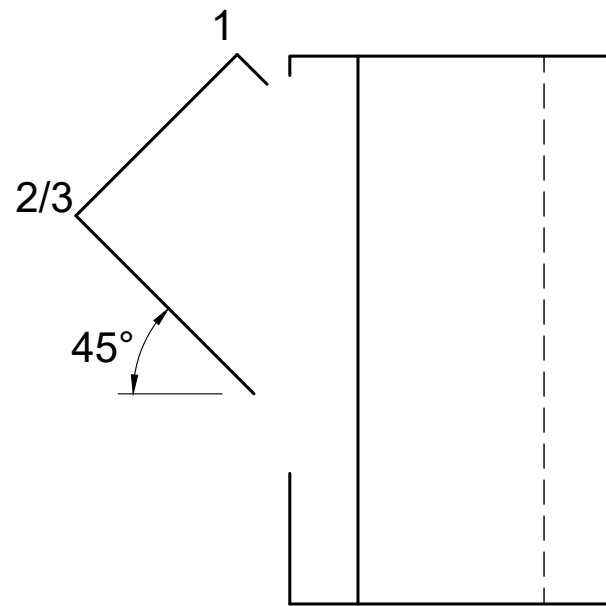

QUESTION 1: INTERPENETRATION

Given:

- The incomplete top view, incomplete front view and auxiliary view of a right equilateral triangular prism that has been shaped to fit around a square prism.
- The auxiliary view of the equilateral triangular prism.
- The starting position (1) of the equilateral triangular branch prism.

Instructions:

Draw the following:

- 1.1 Complete the top view.
- 1.2 Complete the front view clearly showing the curve of interpenetration.
- 1.3 Develop the surface of the equilateral triangular branch prism.

Take note:

- The axes of both prisms lie in a common vertical plane.
- Start the development at position 1, followed by 2 and 3 to end at 1.
- Show all construction lines.
- Show all hidden detail.

[21]

	ASSESSERINGSKRITERA	MARK	E	M
1	Bo-aansig ($\frac{3}{2}$)	1.5		
2	Voor-aansig ($\frac{20}{2}$)	10		
3	Ontvouing ($\frac{18}{2}$)	9.5		
TOTAAL		21		



QUESTION 2: TRANSITION PIECE

Given:

- The top view and front view of a square to square transition piece in first angle orthographic projection.
- The XY line as starting position of the front view
- The starting position of A-B and A-1.

Instructions:

- 2.1 Draw, to scale 1:1, the given front view and top view of the transition piece.
- 2.2 Develop the surface of the transition piece.

Note:

- Number the transition piece the same as the given question.
- Start the transition piece at position A-B & A-1, followed by B, C and D and back to A.
- Show all construction lines and fold lines. [29]

X _____ Y

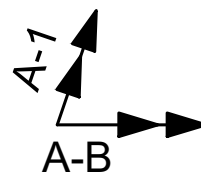
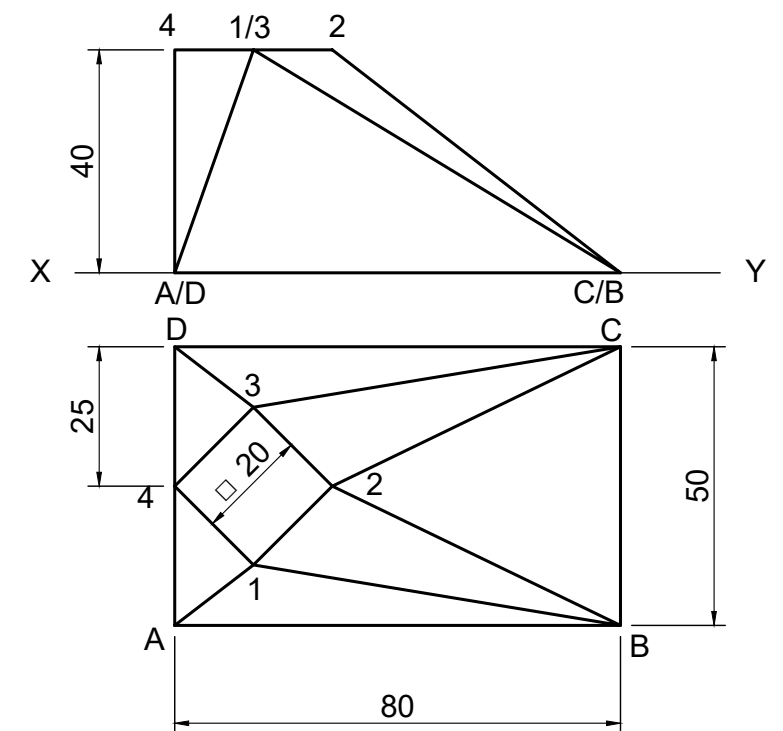

	ASSESSERINGSKRITERA	MARK	E	M
1	VOOR- & BO-AANSIG ($\frac{20}{2}$)	10		
2	KONSTRUKSIES VAN WARE LENGTES ($\frac{12}{2}$)	6		
3	ONTVOUING ($\frac{26}{2}$)	13		
TOTAAL		29		