



# LOCI of a CAM

**Grade 11 & 12**

Developed by: PC Viljoen  
Senior Educational Specialist for  
Engineering Graphics and Design  
Free State Province

# Loci of a CAM: General information

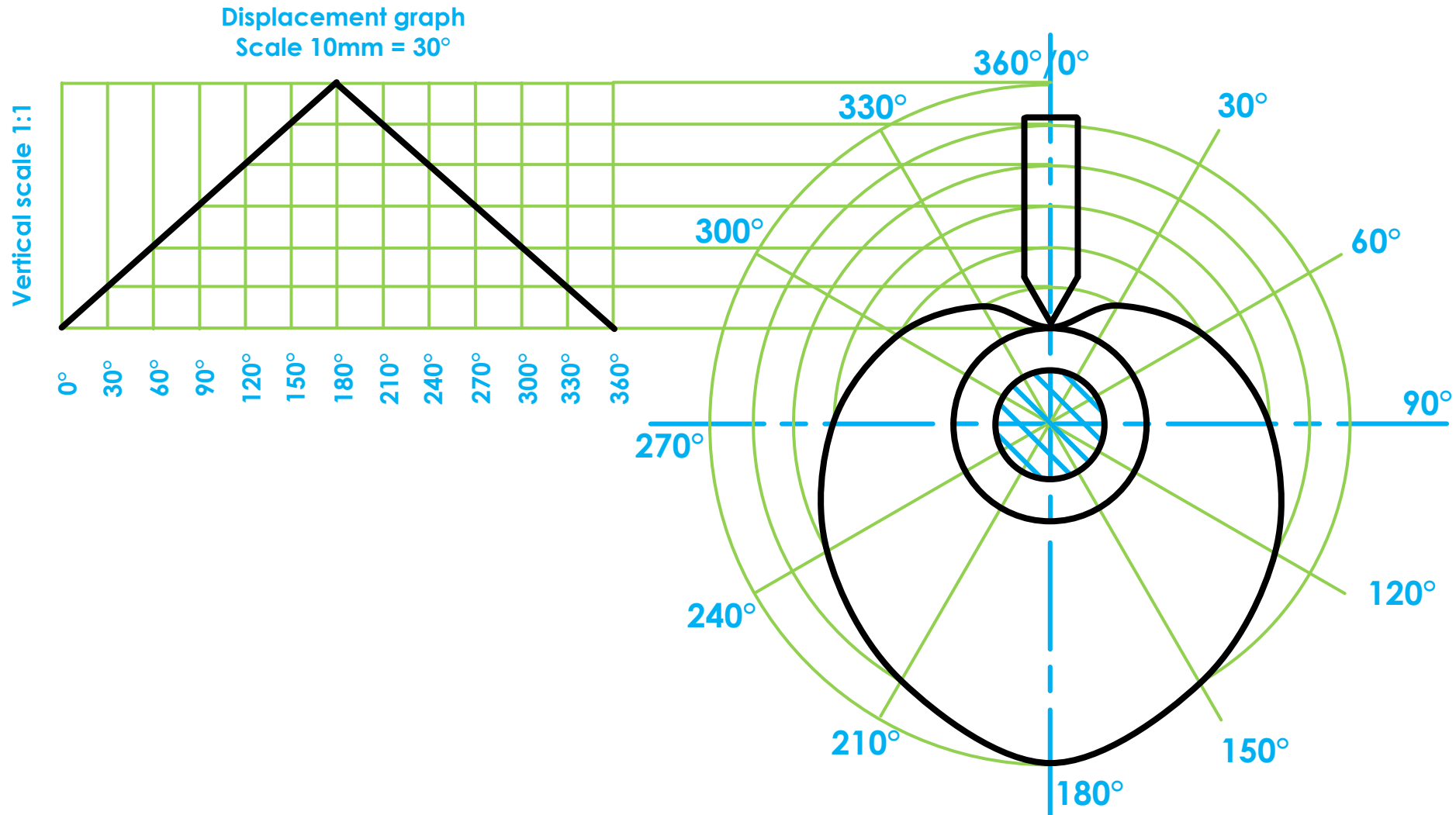

# Loci of a CAM: General information

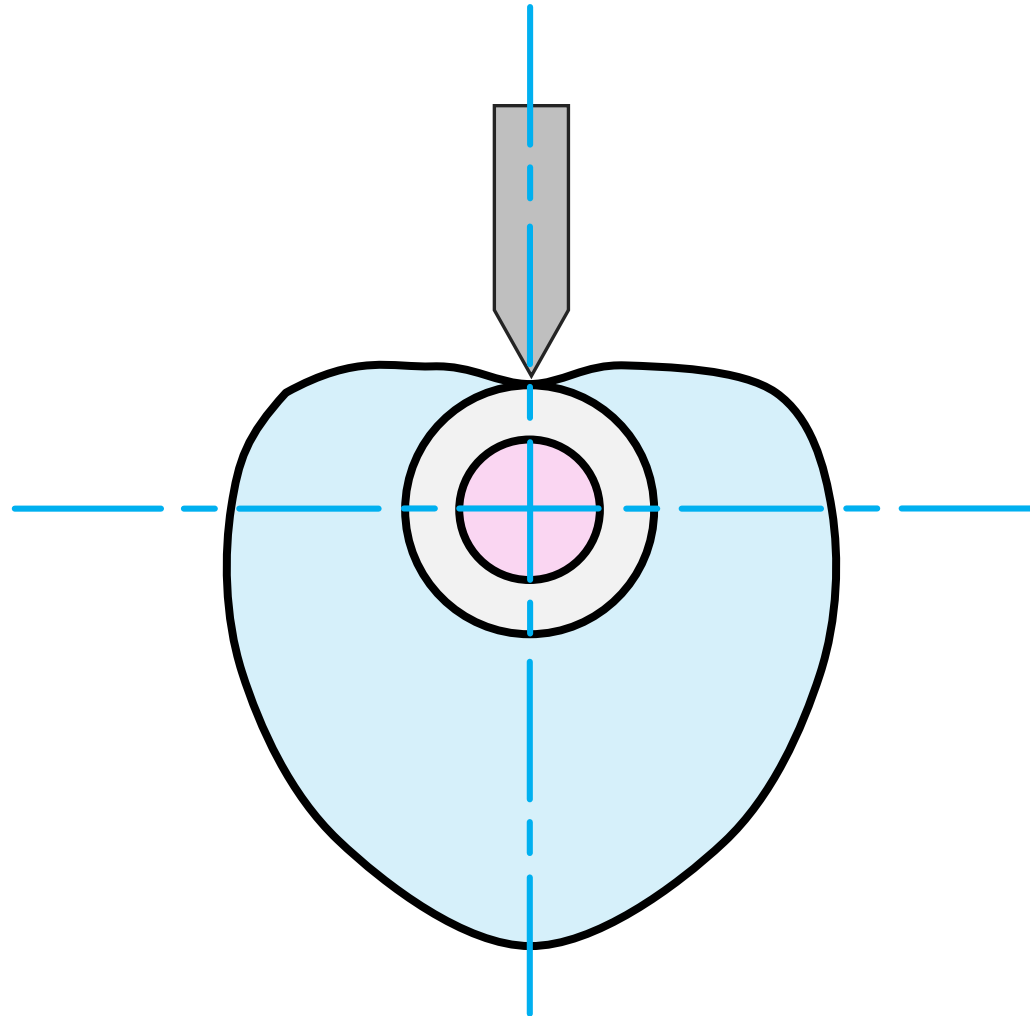
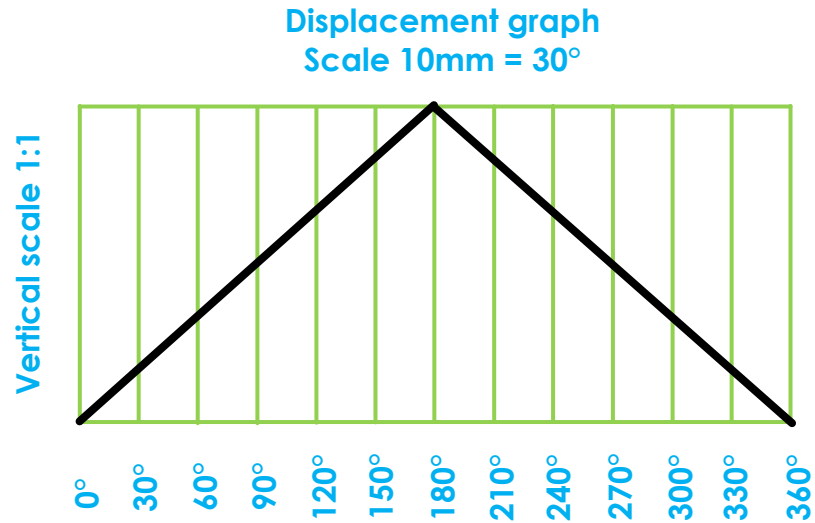

# Loci of a CAM: General information

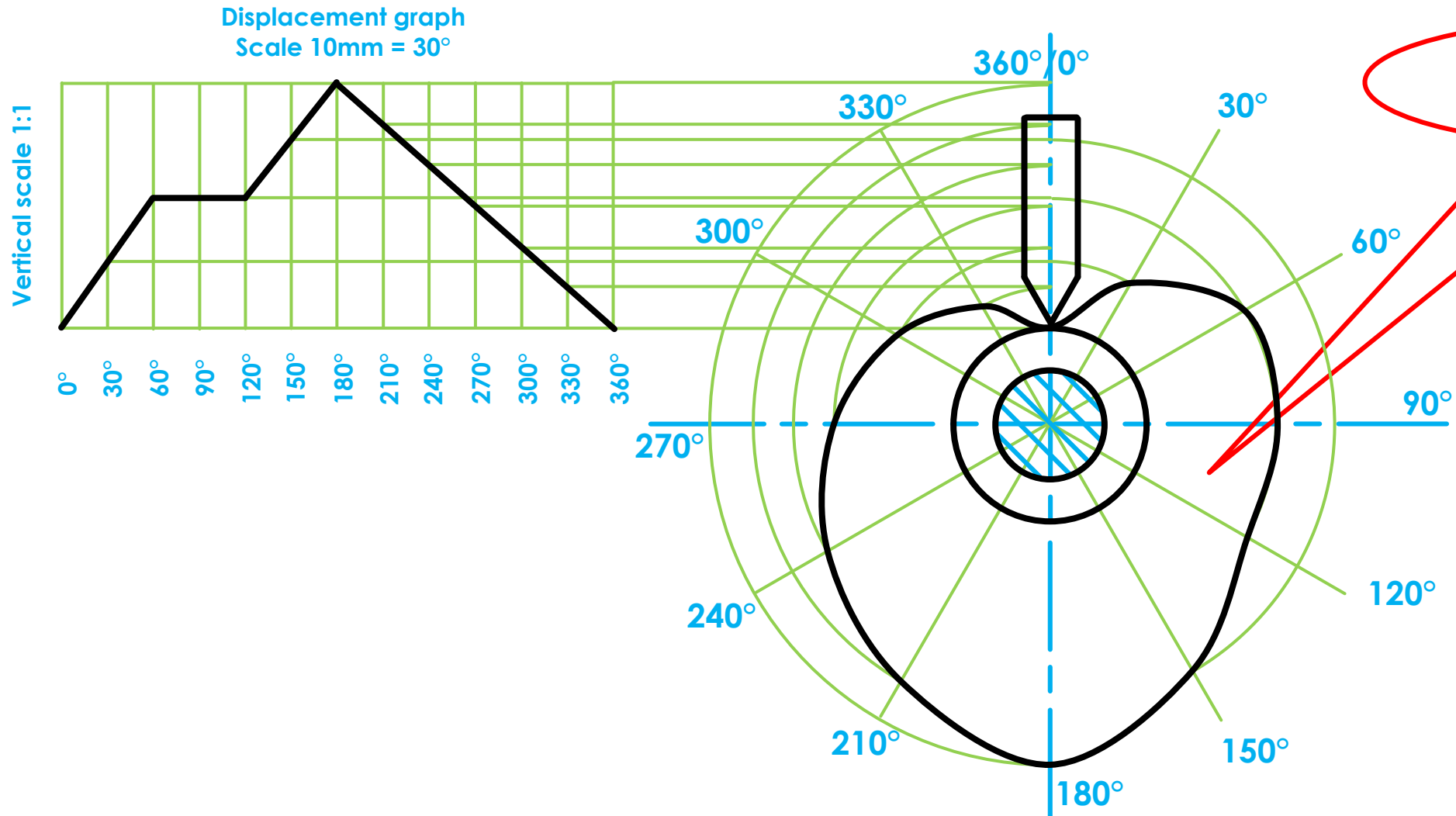

The cam plate

# Loci of a CAM: General information

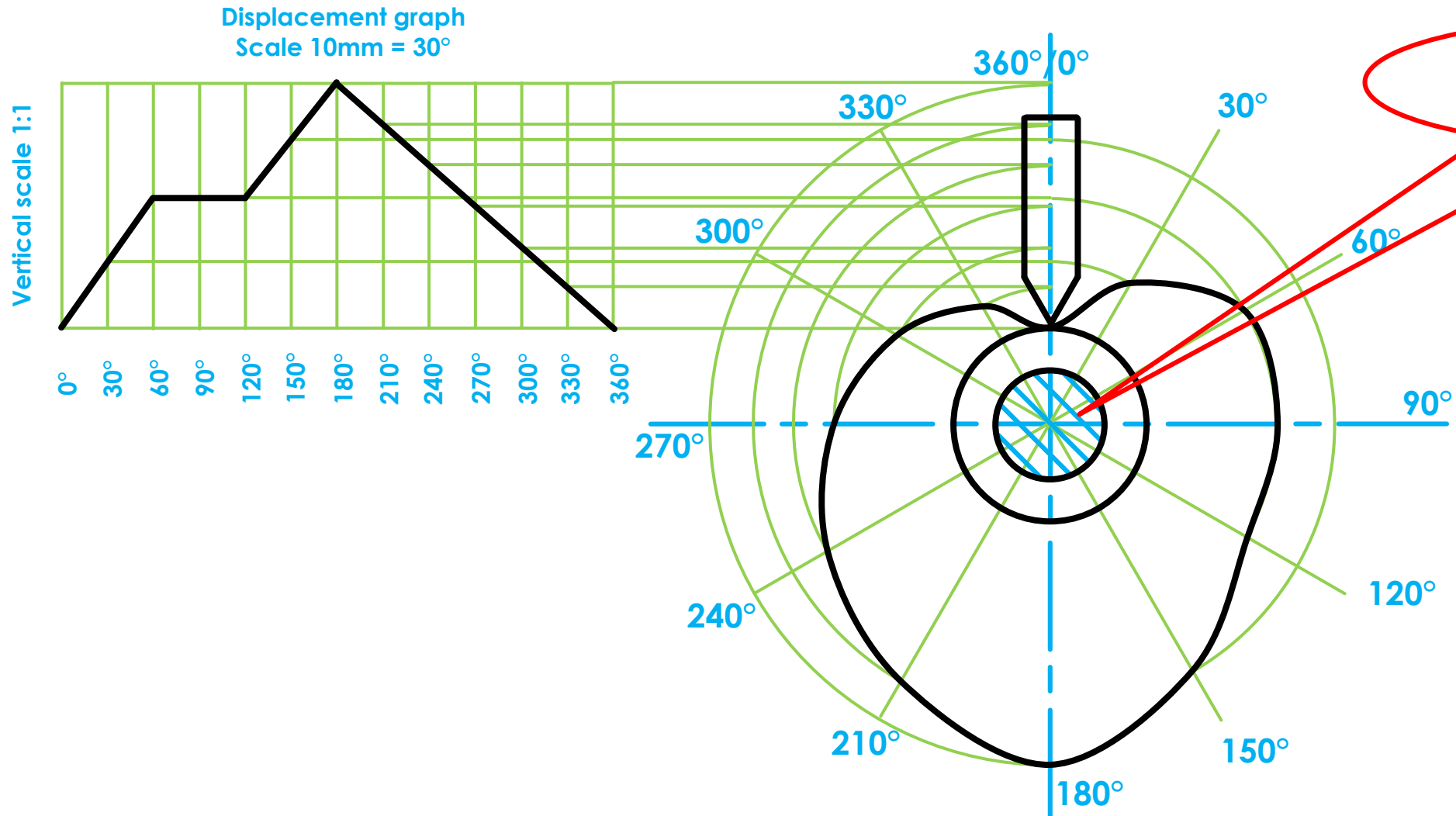

The cam shaft

# Loci of a CAM: General information

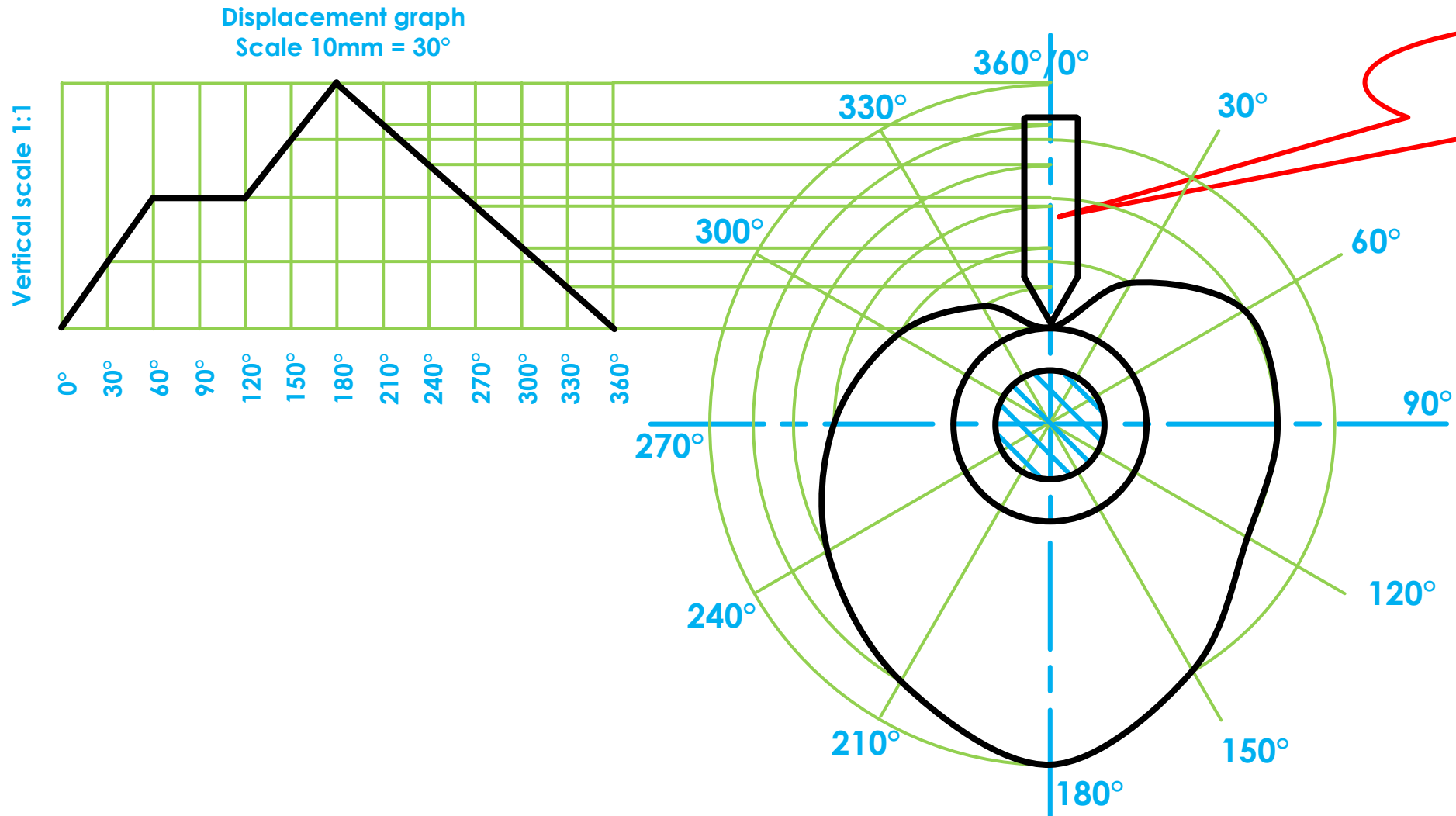

The cam follower

# Loci of a CAM: General information

- The cam plate can rotate in a clockwise or an anti-clockwise direction

# Loci of a CAM: General information

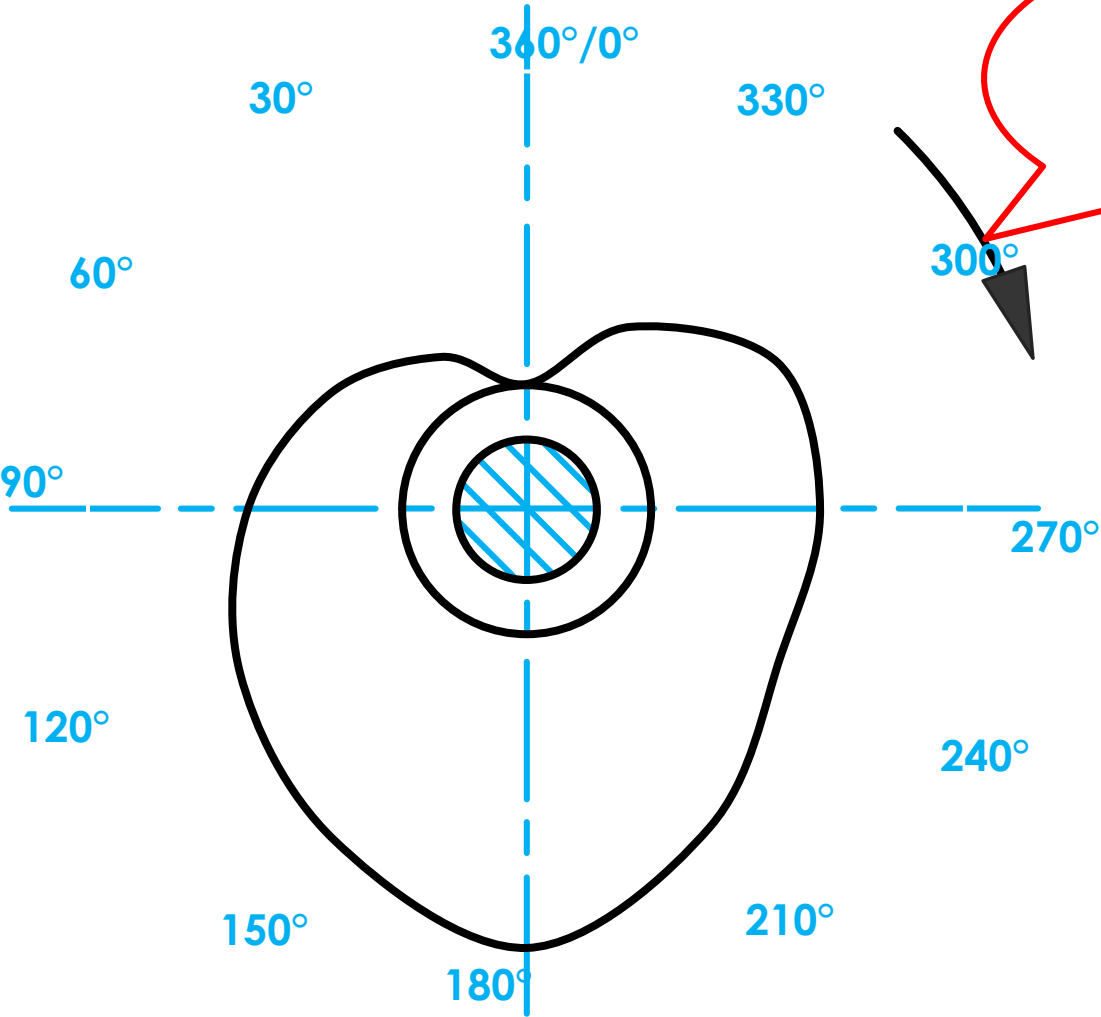
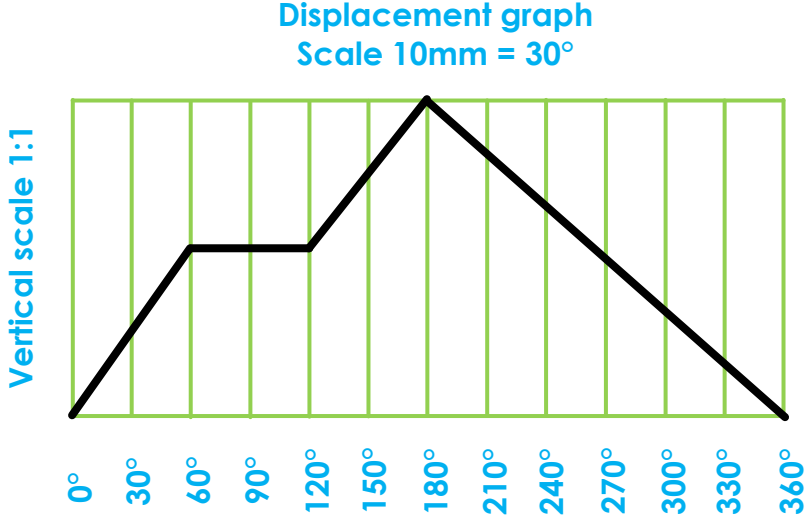

# Loci of a CAM: General information

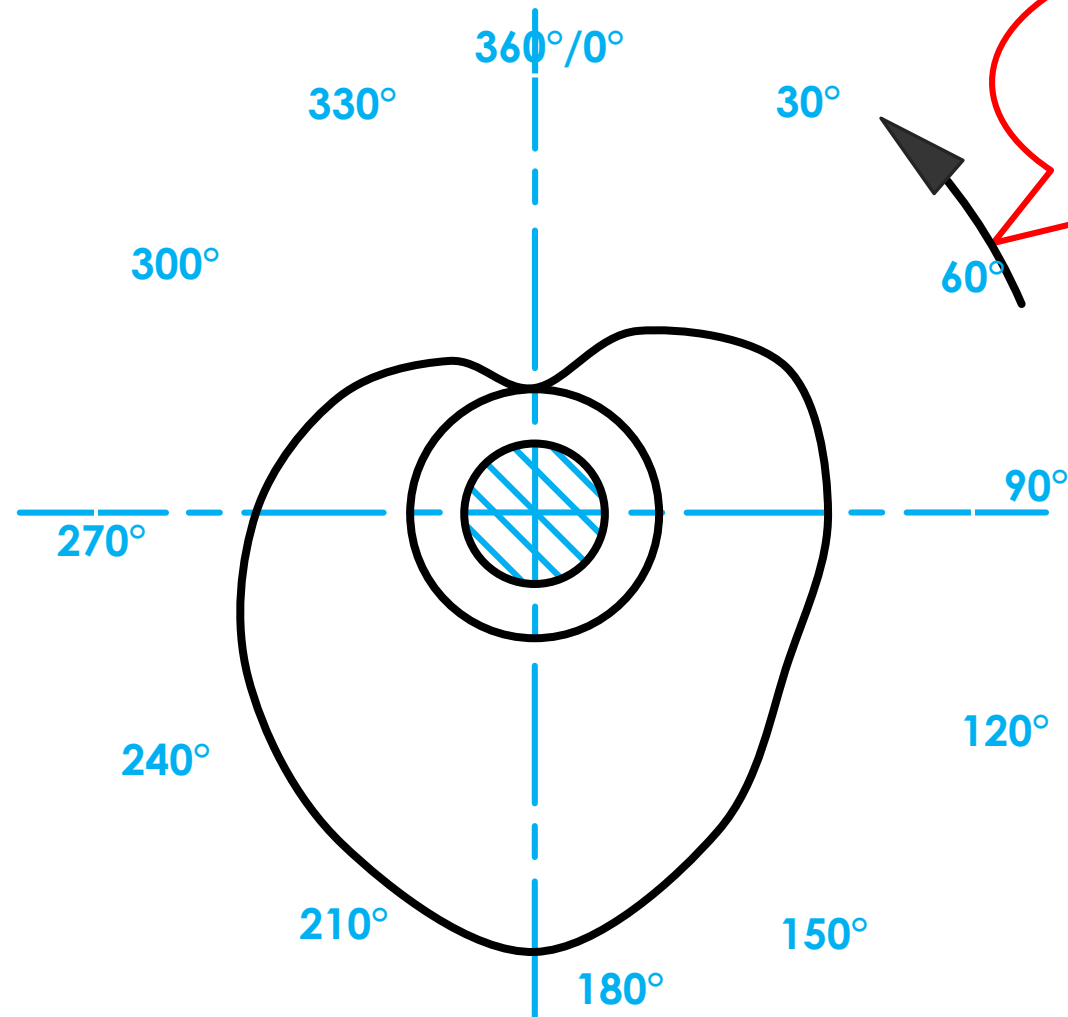
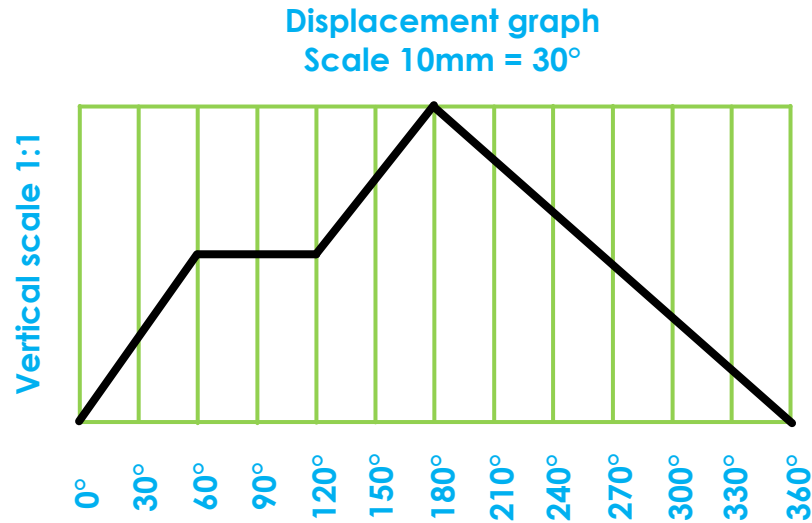

# Loci of a CAM: General information

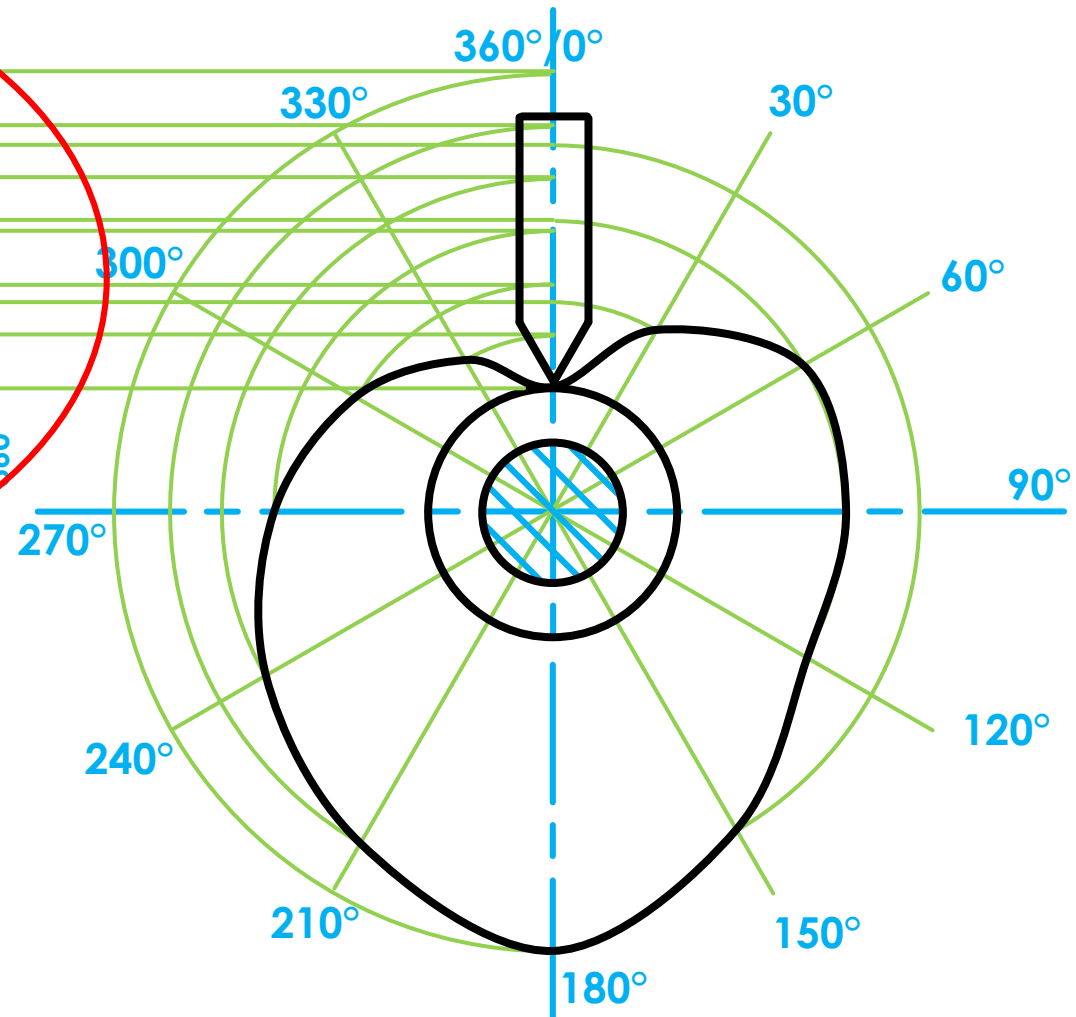
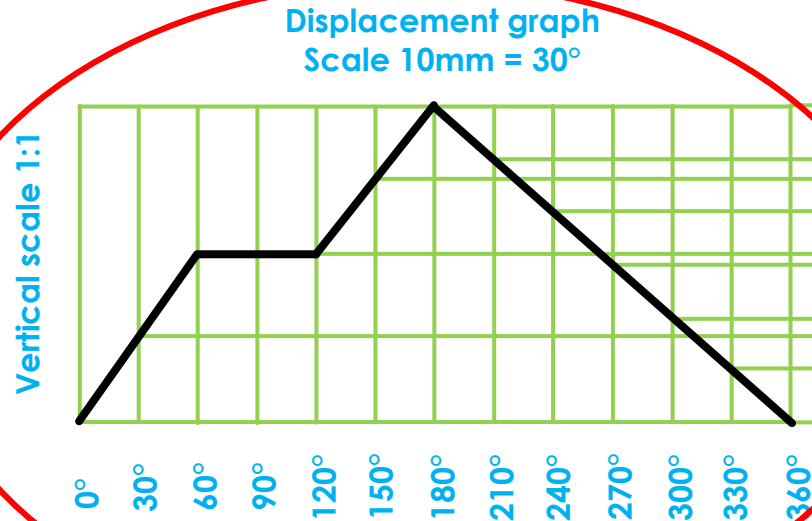

# Loci of a CAM: General information

- There are three different type of movements:
  - Uniform movement
  - Harmonic movement (grade 12 content)
  - Acceleration and retardation movement (grade 12 content)

# Loci of a CAM: UNIFORM MOVEMENT

## By means of uniform motion

- $0^\circ$ - $60^\circ$ : Rise for 50%
- $60^\circ$ - $120^\circ$ : Rest
- $120^\circ$ - $180^\circ$ : Rise to maximum
- $180^\circ$ - $360^\circ$ : Back to original position

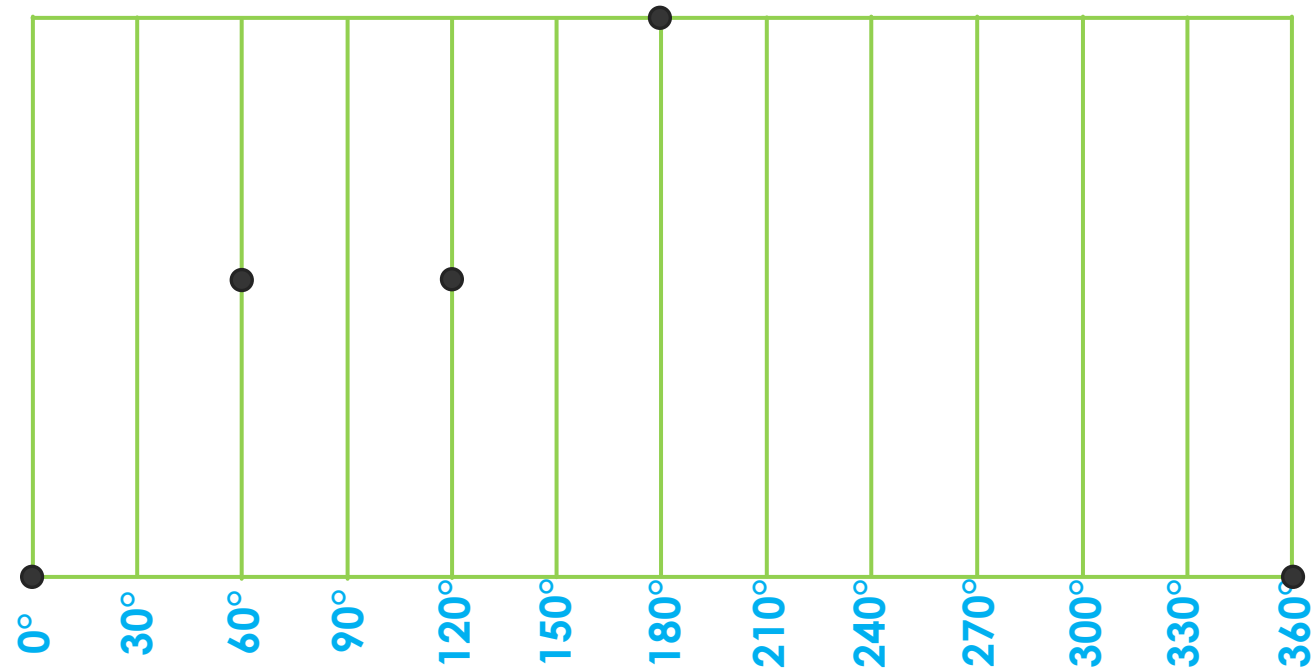

Displacement graph  
Scale 10mm =  $30^\circ$

Vertical scale 1:1

# Loci of a CAM: UNIFORM MOVEMENT

## By means of uniform motion

- $0^{\circ}$ - $60^{\circ}$ : Rise for 50%
- $60^{\circ}$ - $120^{\circ}$ : Rest
- $120^{\circ}$ - $180^{\circ}$ : Rise to maximum
- $180^{\circ}$ - $360^{\circ}$ : Back to original position

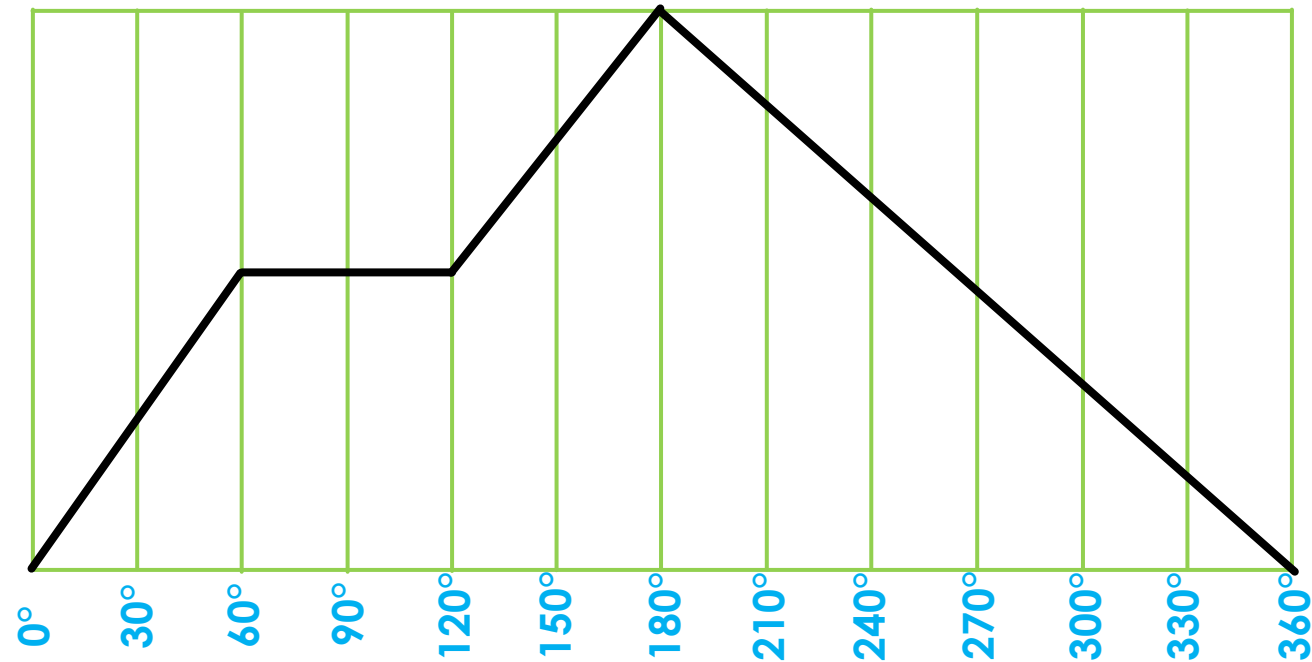

Vertical scale 1:1

Displacement graph  
Scale 10mm = 30°

# Loci of a CAM: General information

- There are three different type of movements:
  - Uniform movement
  - Harmonic movement (grade 12 content)
  - Acceleration and retardation movement (grade 12 content)

# Loci of a CAM: HARMONIC MOVEMENT

- $0^\circ$ - $180^\circ$ :  
Rise by means of **Harmonic movement**
- $180^\circ$ - $360^\circ$ :  
Move to original position by means of **Uniform movement**

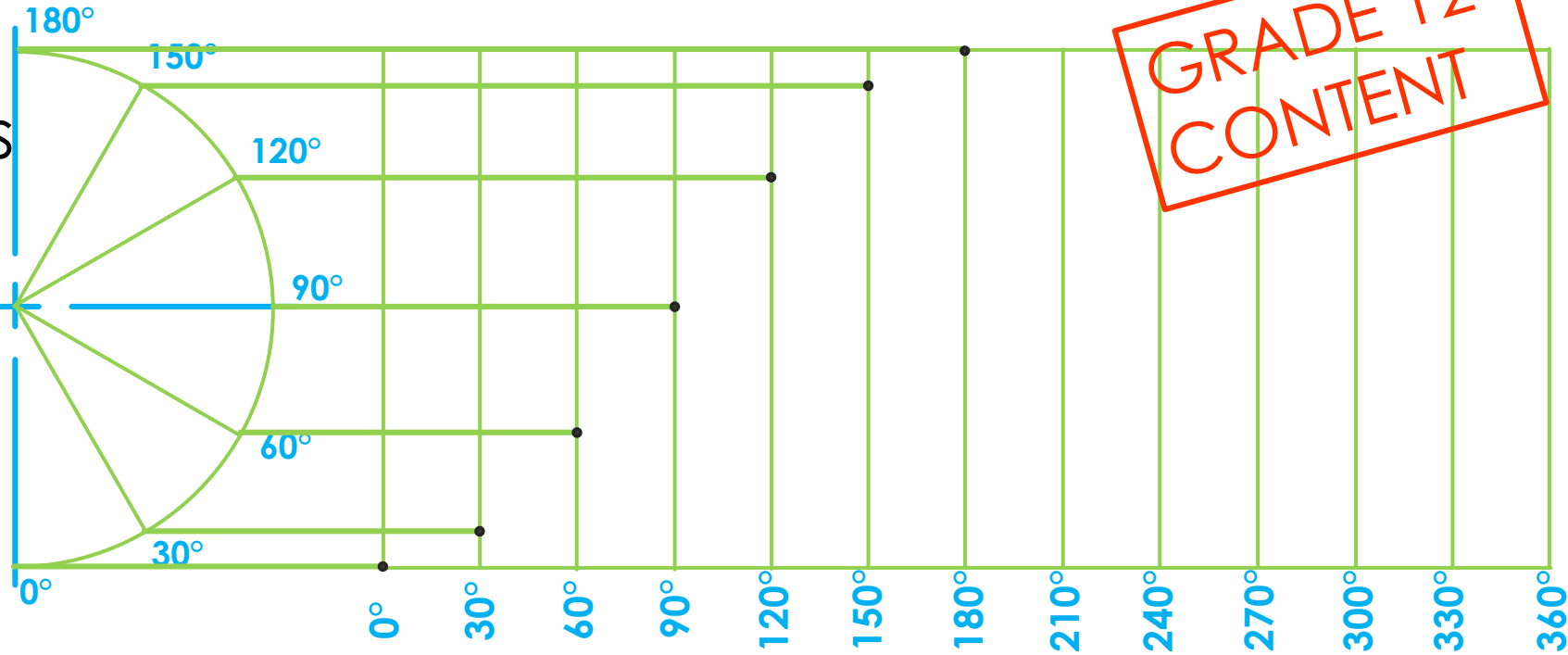

Displacement graph  
Scale 10mm =  $30^\circ$

Vertical scale 1:1

# Loci of a CAM: HARMONIC MOVEMENT

- $0^\circ$ - $180^\circ$ :  
Rise by means of **Harmonic movement**
- $180^\circ$ - $360^\circ$ :  
Move to original position by means of **Uniform movement**

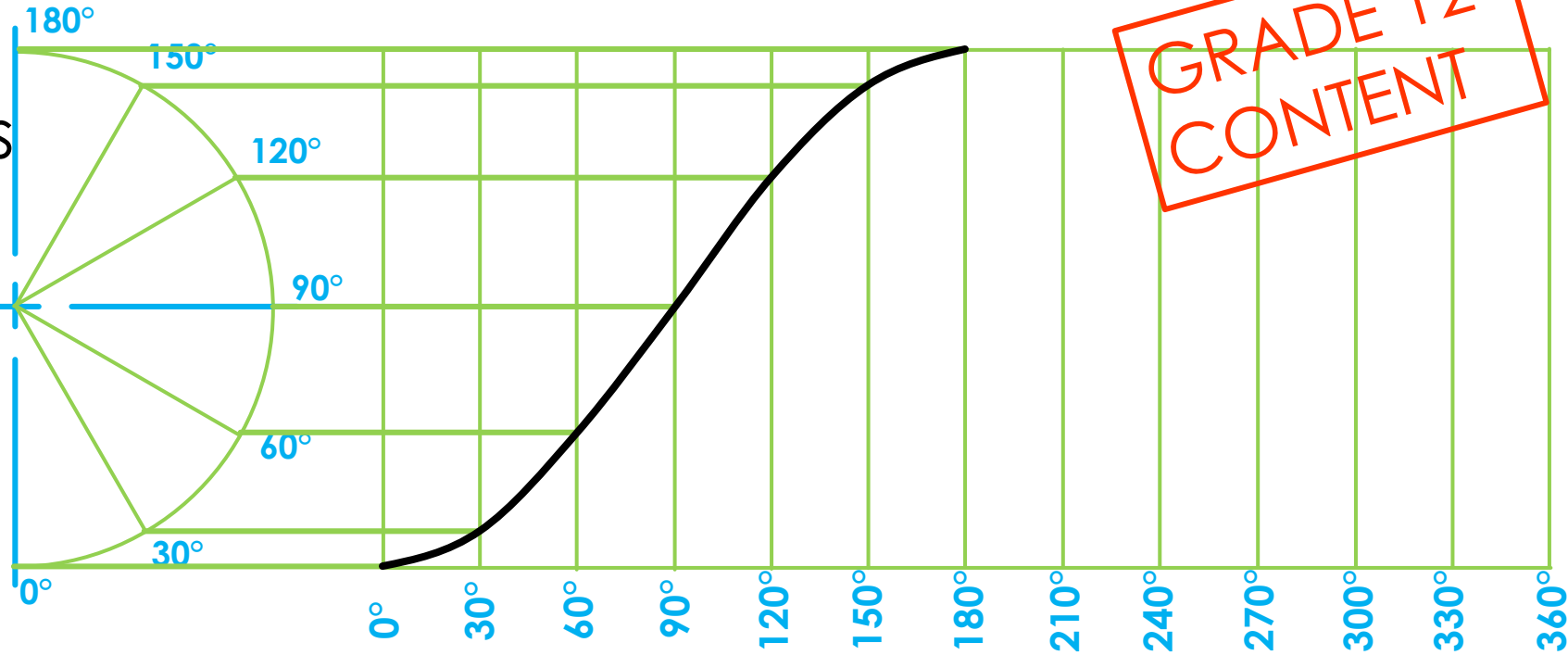

Displacement graph  
Scale 10mm =  $30^\circ$

Vertical scale 1:1

# Loci of a CAM: General information

- There are three different type of movements:
  - Uniform movement
  - Harmonic movement (grade 12 content)
  - Acceleration and retardation movement (grade 12 content)

# Loci of a CAM: ACCELERATION & RETARDATION MOVEMENT

Equal number

- $0^\circ$ - $240^\circ$ : Rise for 50mm by means of **acceleration and retardation movement**
- $240^\circ$ - $360^\circ$ : Back to original position by means of **uniform motion**

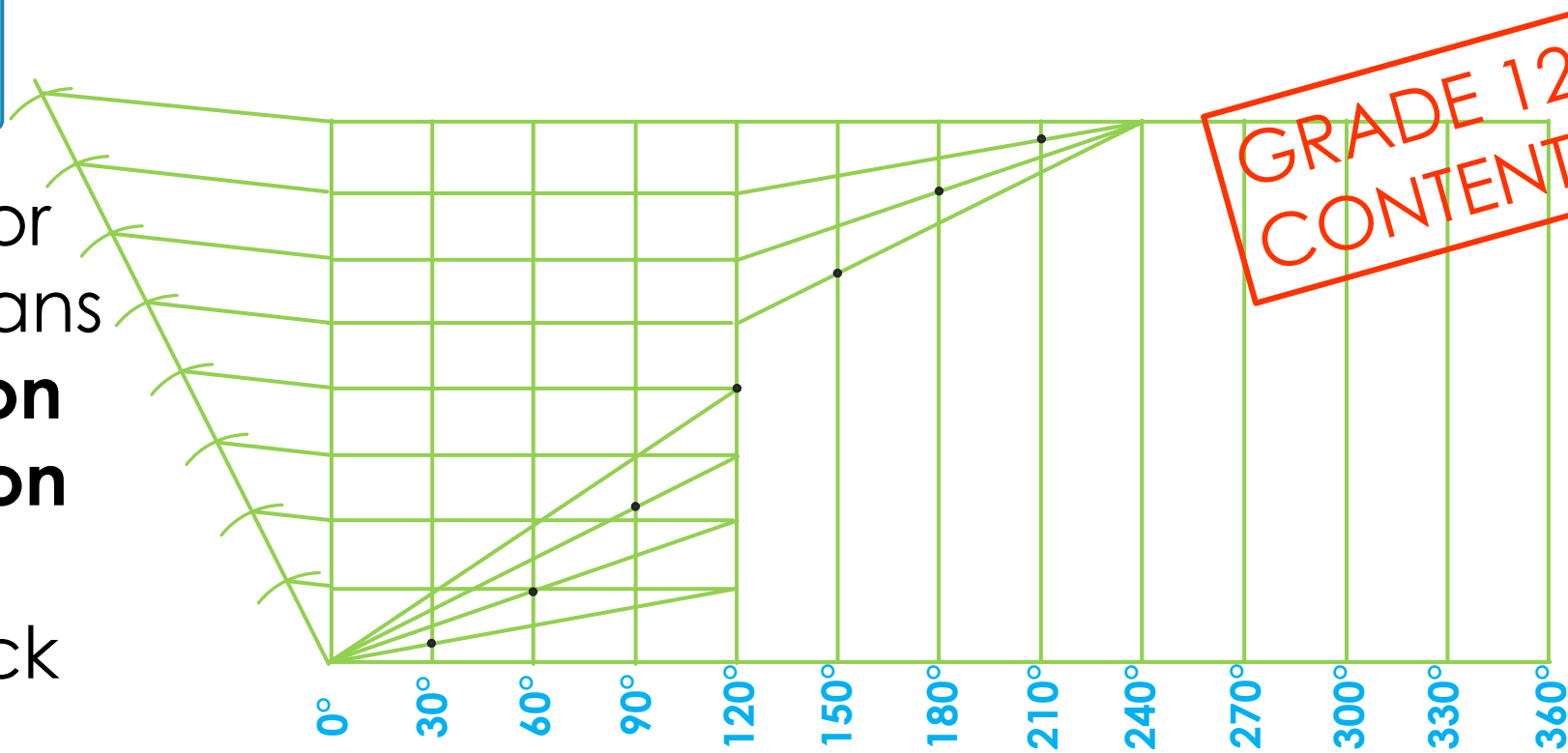

Displacement graph  
Scale 10mm =  $30^\circ$

Vertical scale 1:1

# Loci of a CAM: ACCELERATION & RETARDATION MOVEMENT

Equal number

- $0^\circ$ - $240^\circ$ : Rise for 50mm by means of **acceleration and retardation movement**
- $240^\circ$ - $360^\circ$ : Back to original position by means of **uniform motion**

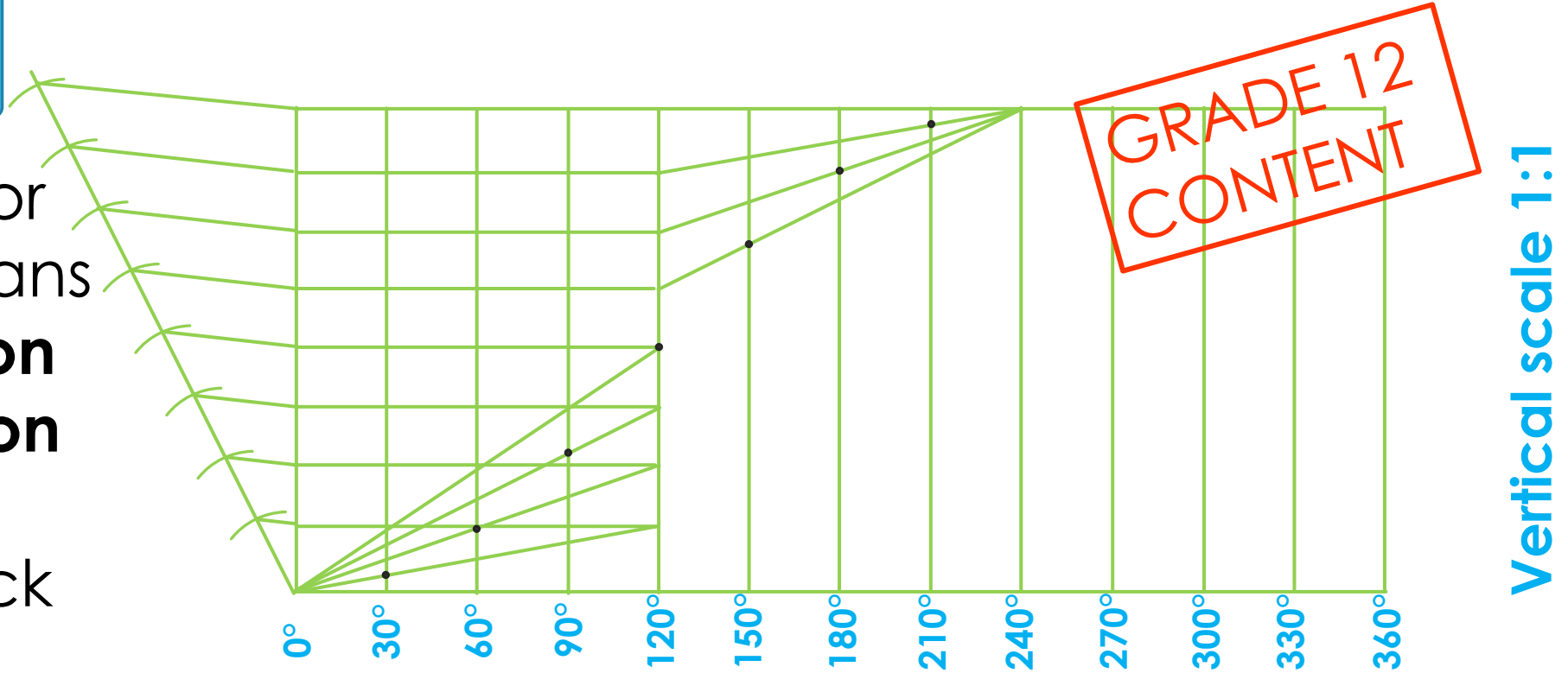

Displacement graph  
Scale 10mm =  $30^\circ$

# Loci of a CAM: ACCELERATION & RETARDATION MOVEMENT

Equal number

- $0^\circ$ - $240^\circ$ : Rise for 50mm by means of **acceleration and retardation movement**
- $240^\circ$ - $360^\circ$ : Back to original position by means of **uniform motion**

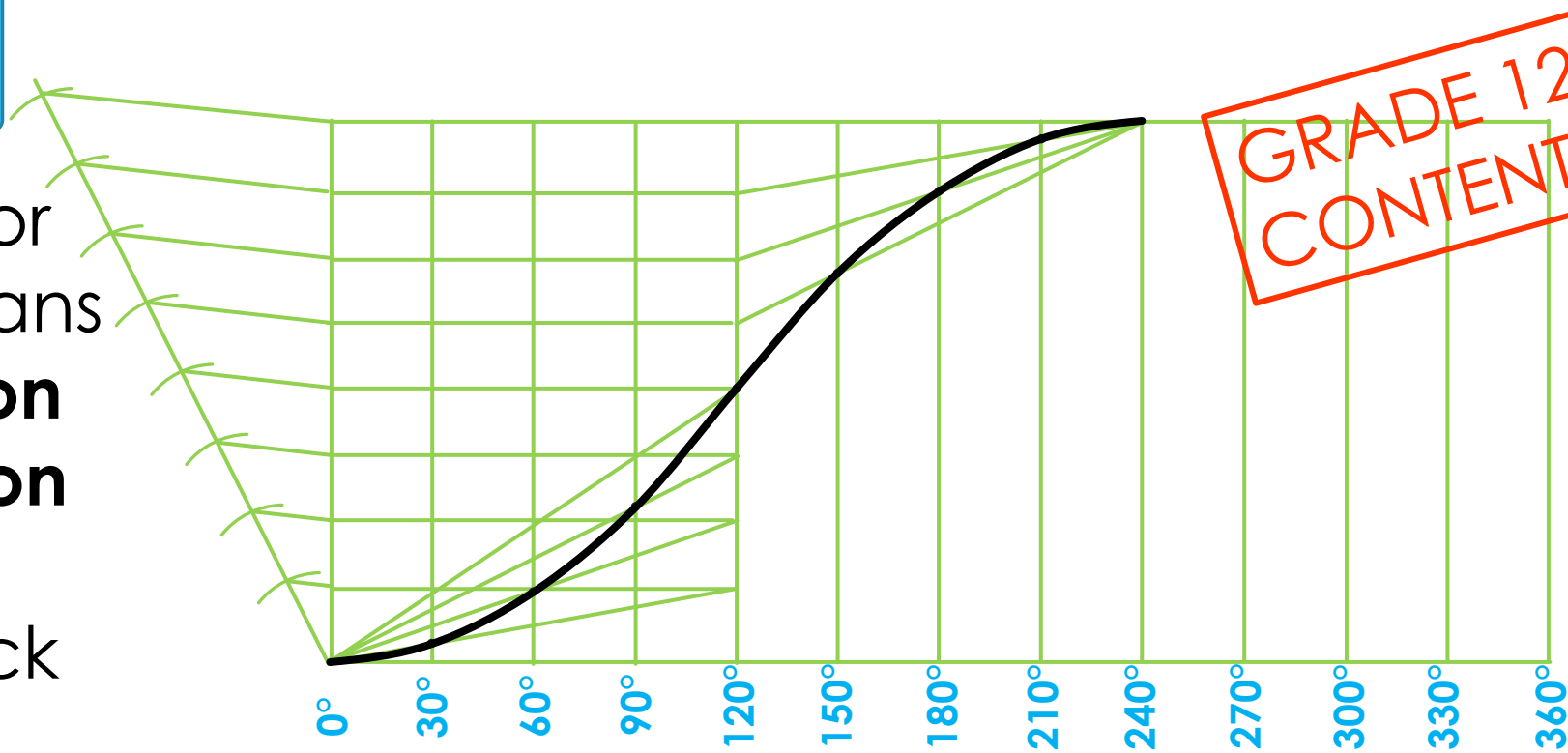

Displacement graph  
Scale 10mm =  $30^\circ$

Vertical scale 1:1

# Loci of a CAM: General information

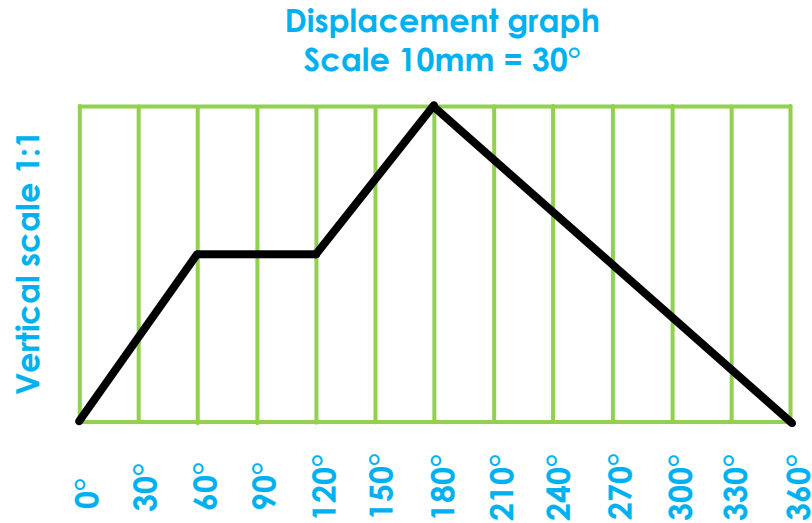

- The information on the displacement graph need to be transferred towards the cam plate

# Loci of a CAM: General information

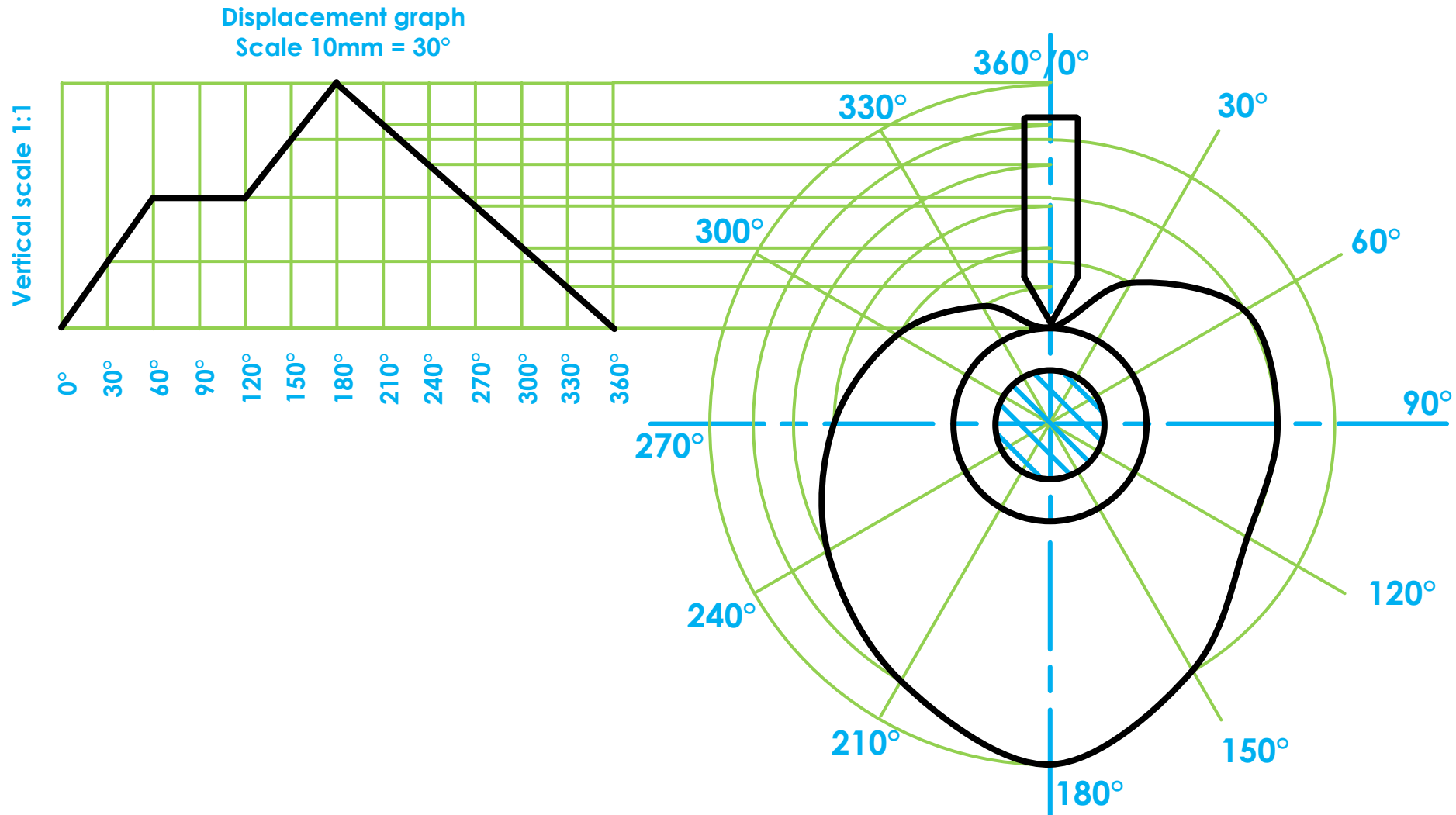

# Loci of a CAM: General information

- The follower can be at a vertical angle, slanted angle or horizontal angle.

# Loci of a CAM: General information

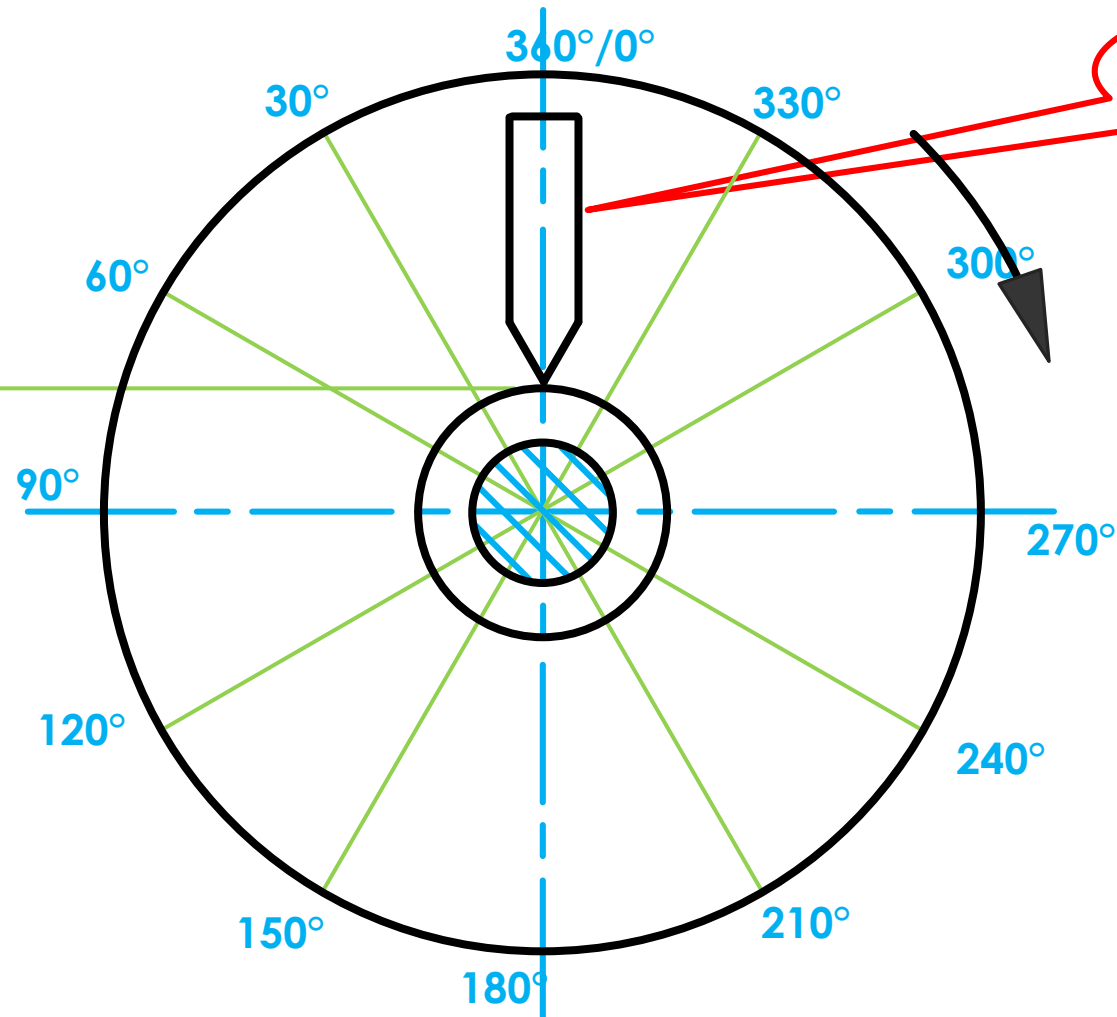
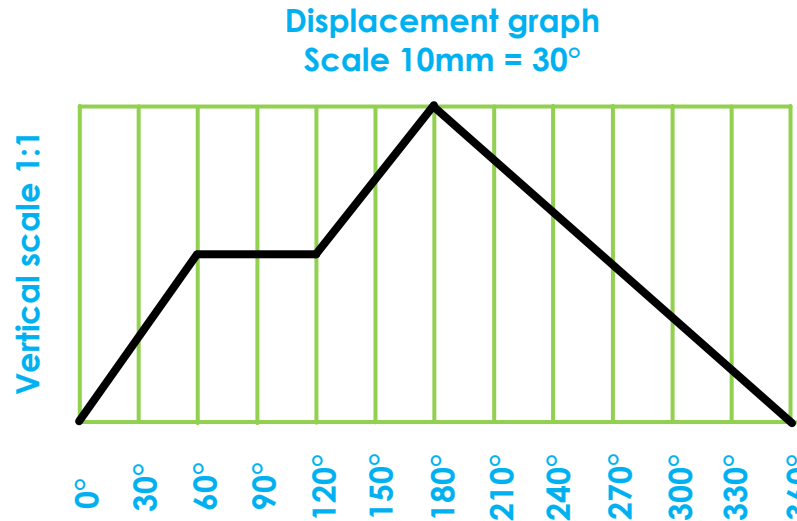

# Loci of a CAM: General information

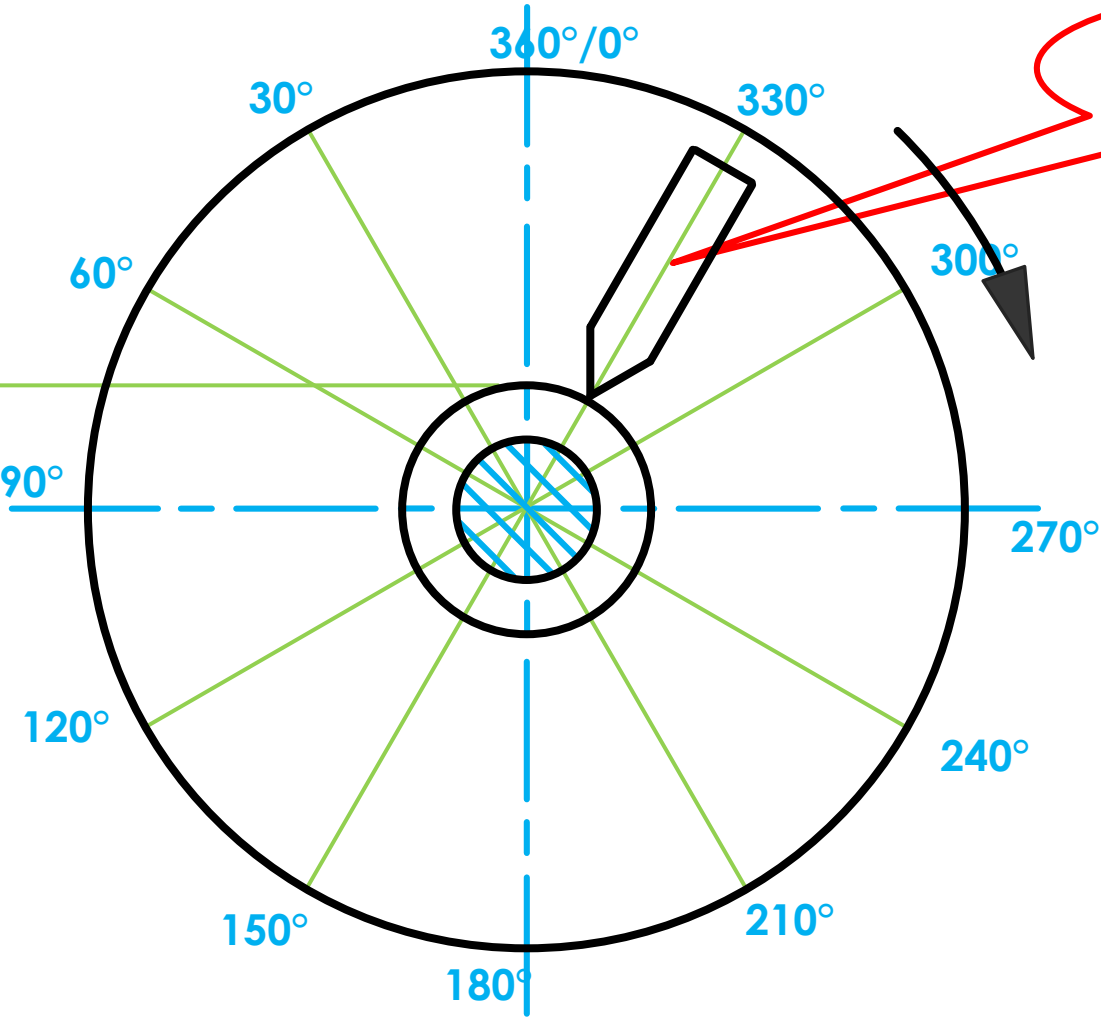
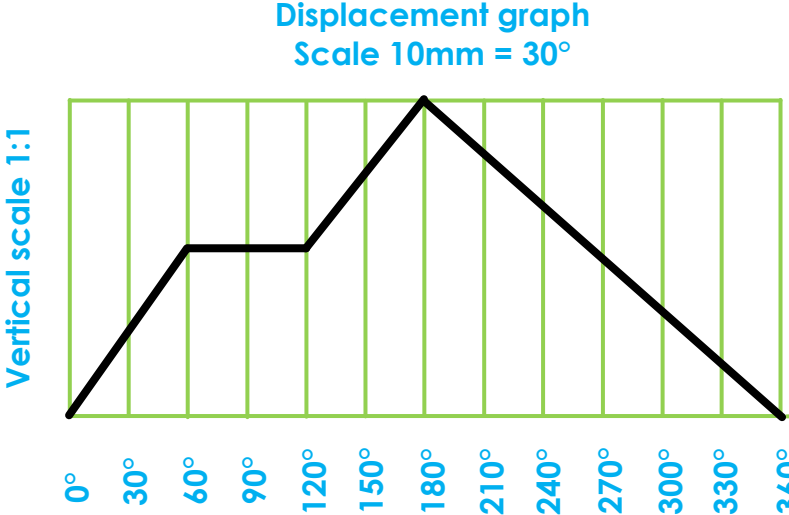

Follower at a slanted angle

GRADE 12  
CONTENT

# Loci of a CAM: General information

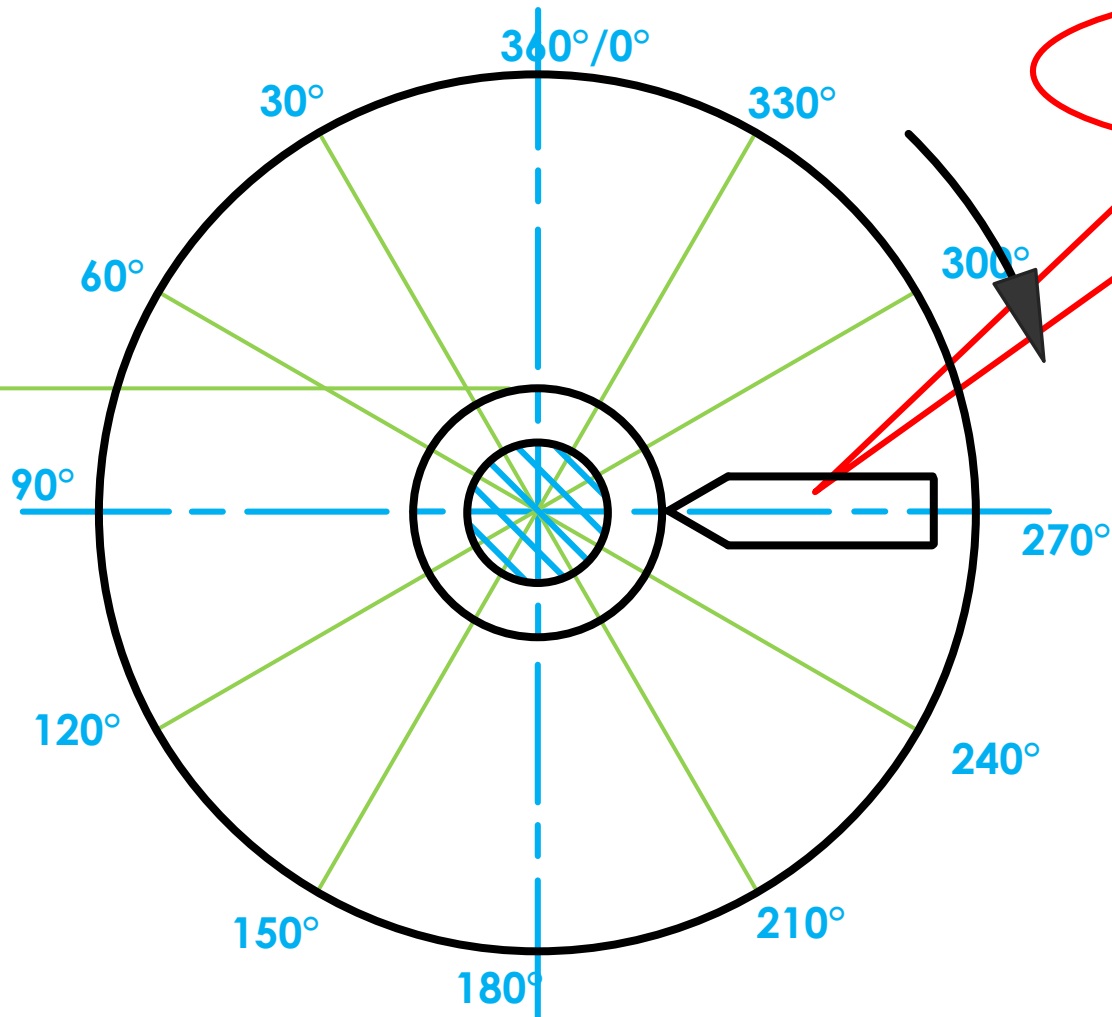
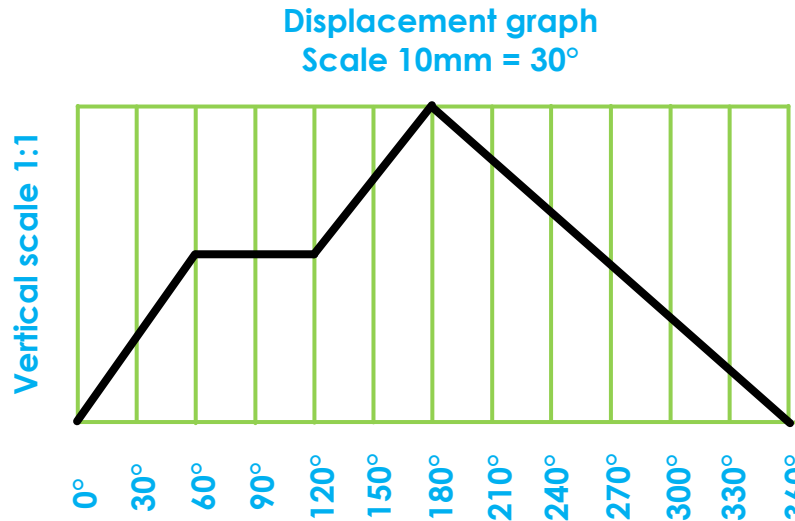

Follower at a horizontal angle

GRADE 12  
CONTENT