



# LOCI of a CAM

**Grade 11 & 12**

Developed by: PC Viljoen  
Senior Educational Specialist for  
Engineering Graphics and Design  
Free State Province

# Loci of a CAM: General information

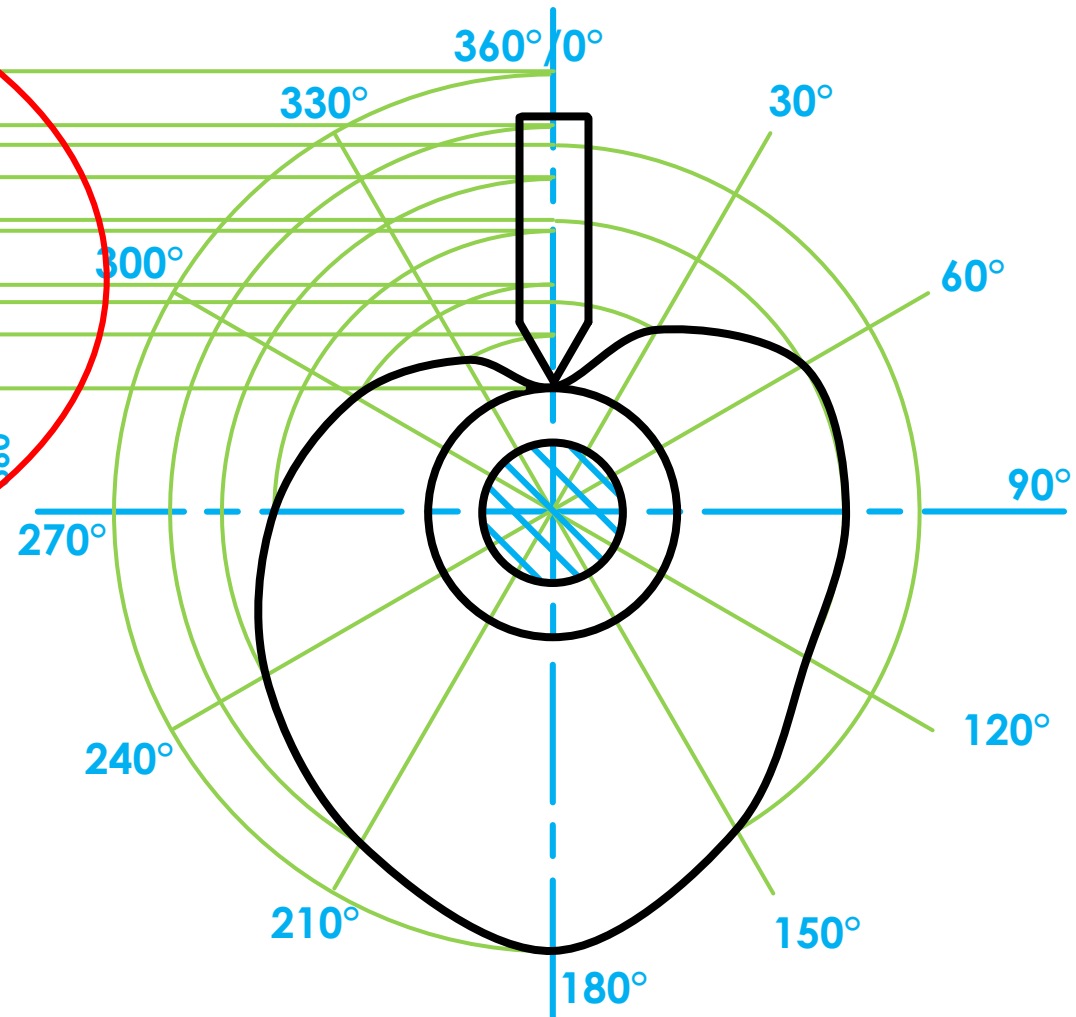
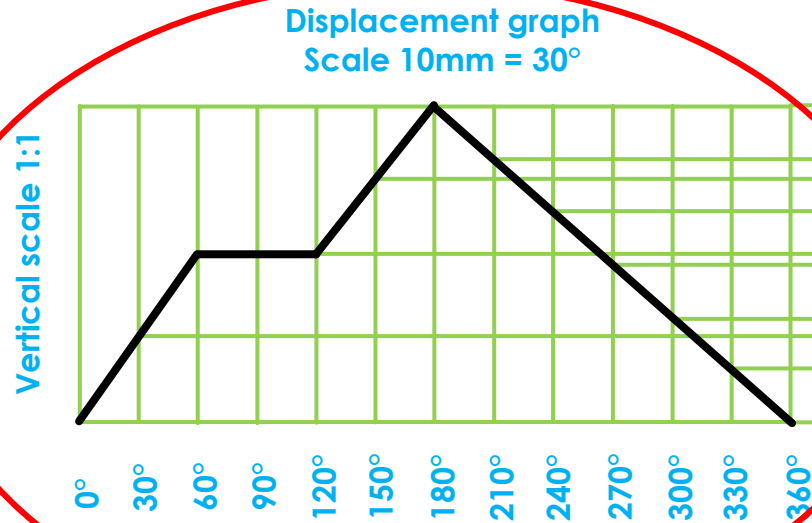

# Loci of a CAM: General information

- What is a displacement graph?
  - A displacement graph indicate the different motions of a cam during each stage
  - The vertical scale indicates the max height to which the follower can rise

# Loci of a CAM: General information

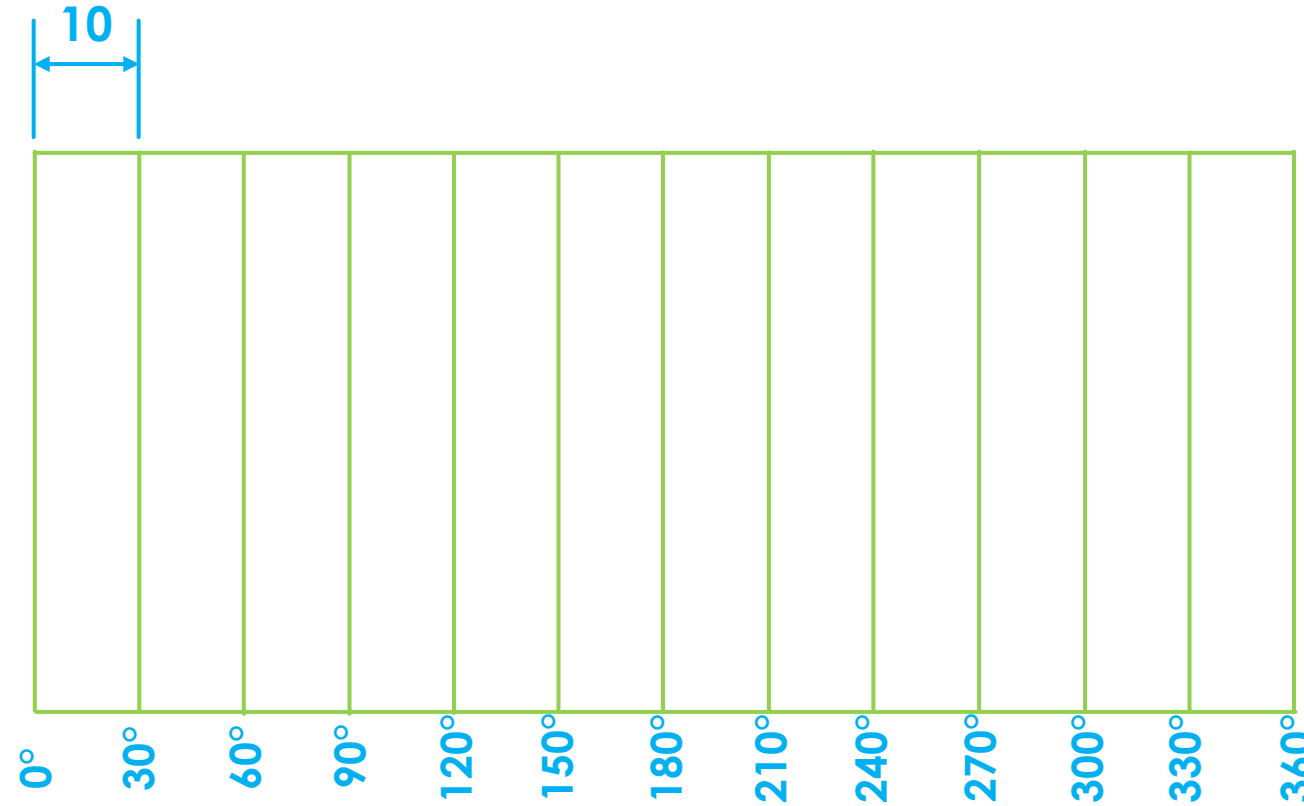

Vertical scale 1:1  
Maximum height  
= 60mm

Displacement graph  
Scale 10mm = 30°

# Loci of a CAM: General information

- What is a displacement graph?
  - The displacement graph indicate one rotation of  $360^\circ$  of the cam shaft and cam plate
  - Normally there will be 12 stages, depending of the accuracy of the follower
  - The stages are normally divided into degrees
  - The displacement graph will therefor represent  $360^\circ$  to indicate 12 different stages

# Loci of a CAM: General information

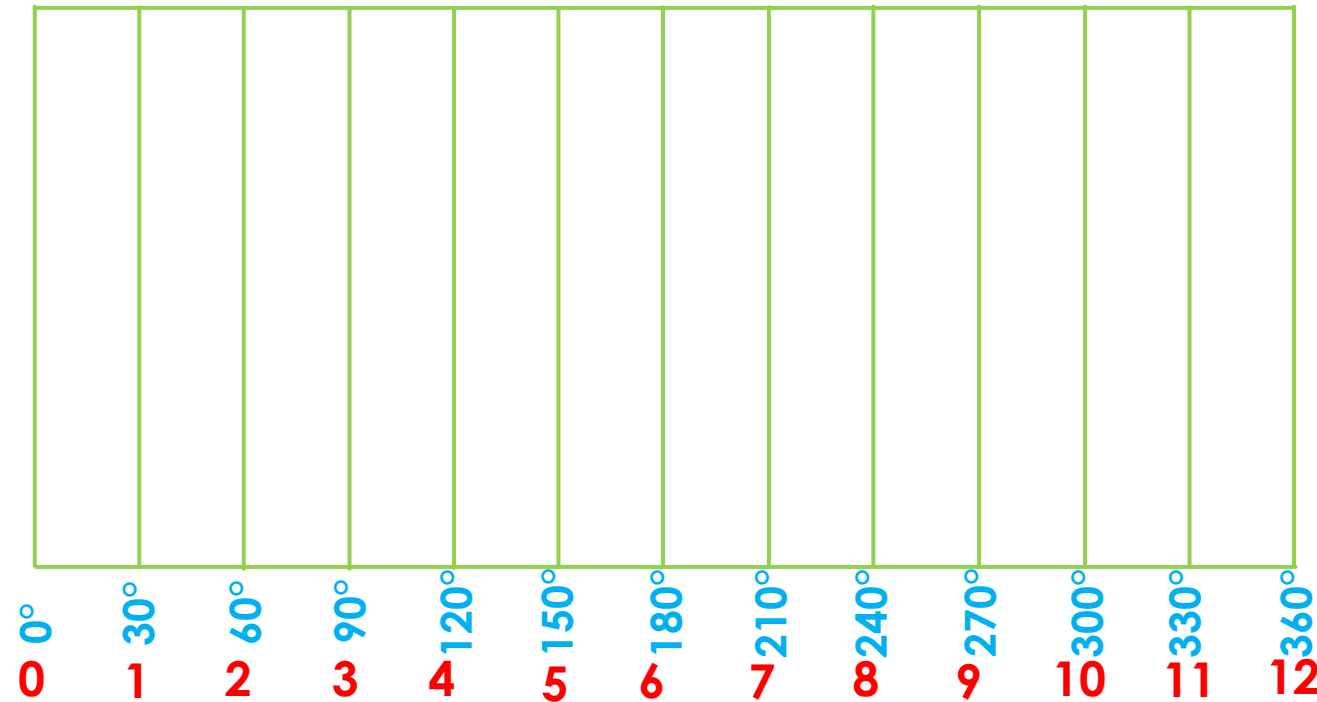

Displacement graph  
Scale 10mm = 30°

Vertical scale 1:1  
Maximum height  
= 60mm

# Loci of a CAM

## By means of uniform motion

- $0^\circ$ - $60^\circ$ : Rise for 50%
- $60^\circ$ - $120^\circ$ : Rest
- $120^\circ$ - $180^\circ$ : Rise to maximum 60mm
- $180^\circ$ - $360^\circ$ : Back to original position

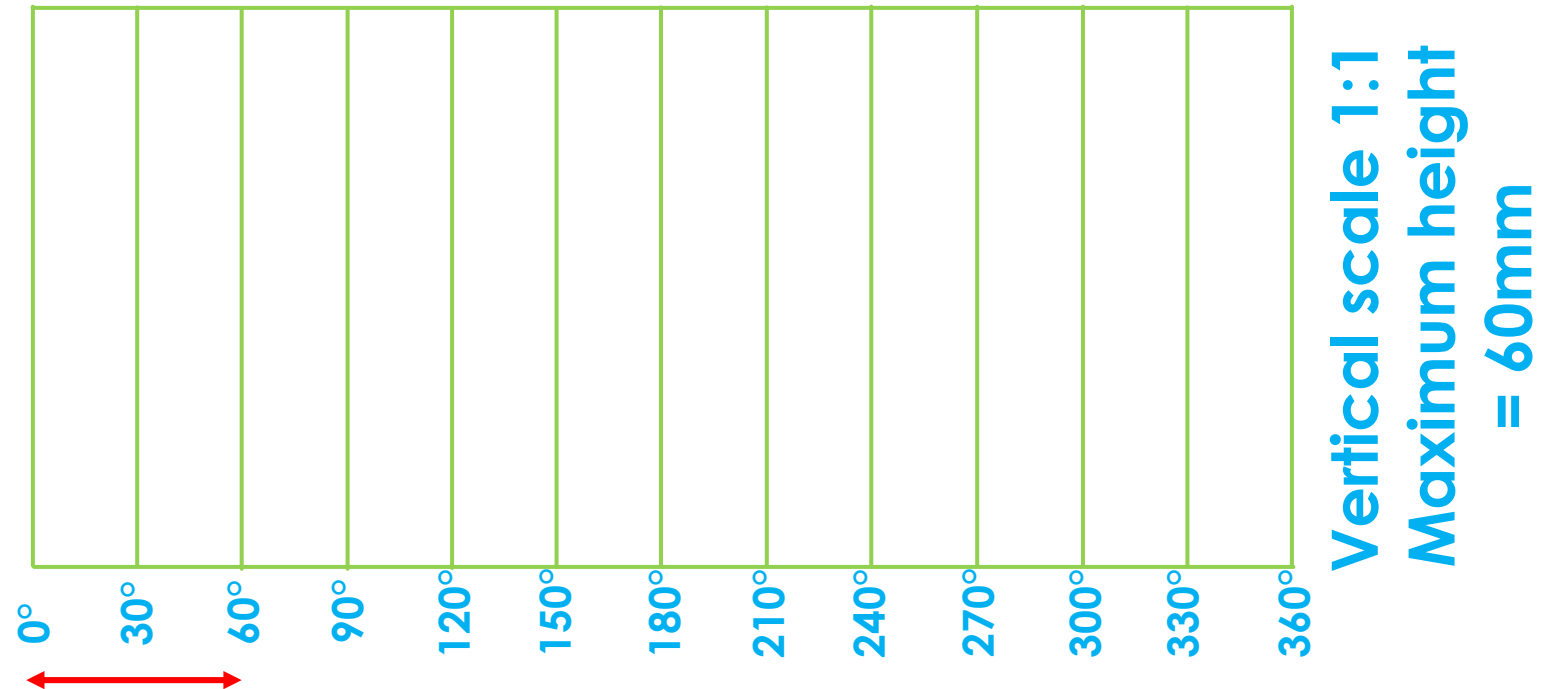

Displacement graph  
Scale 10mm =  $30^\circ$

# Loci of a CAM

## By means of uniform motion

- $0^\circ$ - $60^\circ$ : Rise for 50%
- $60^\circ$ - $120^\circ$ : Rest
- $120^\circ$ - $180^\circ$ : Rise to maximum 60mm
- $180^\circ$ - $360^\circ$ : Back to original position

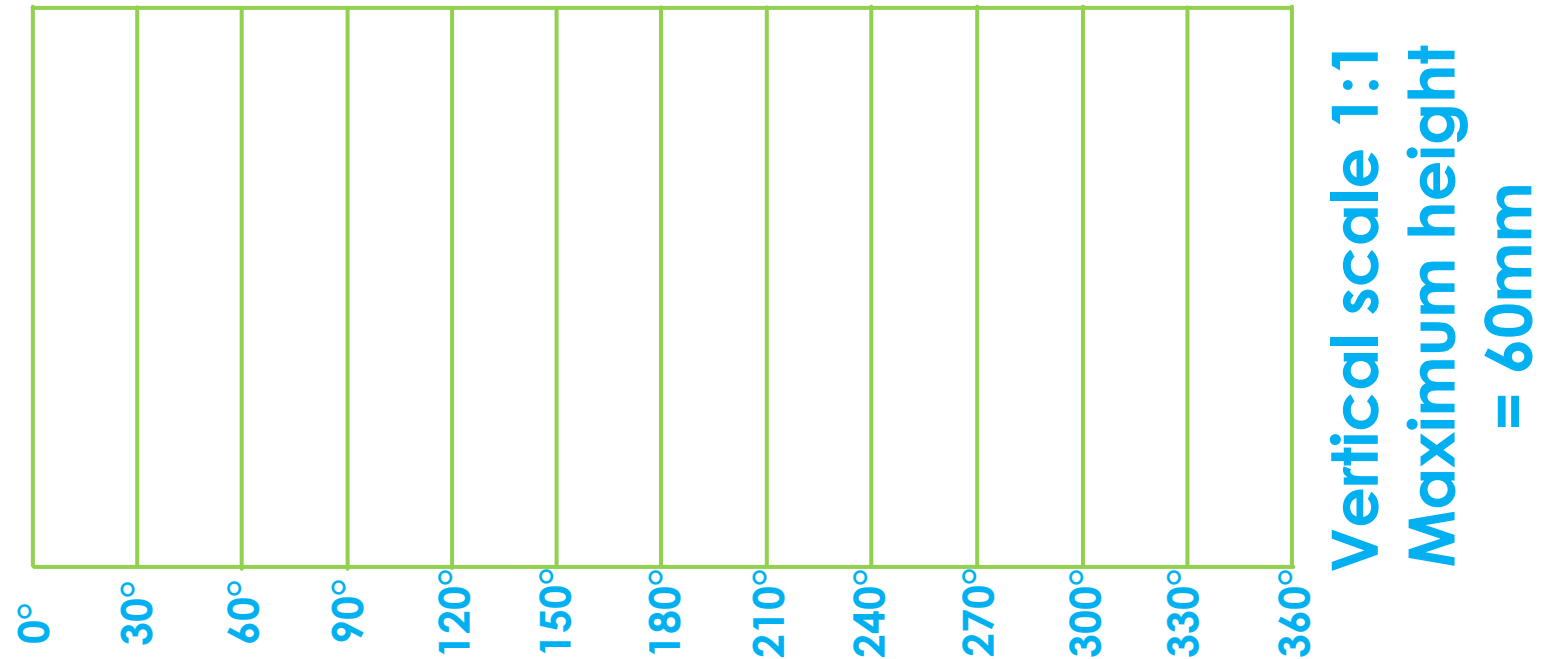

Displacement graph  
Scale 10mm =  $30^\circ$

# Loci of a CAM

## By means of uniform motion

- $0^\circ$ - $60^\circ$ : Rise for 50%
- $60^\circ$ - $120^\circ$ : Rest
- $120^\circ$ - $180^\circ$ : Rise to maximum 60mm
- $180^\circ$ - $360^\circ$ : Back to original position

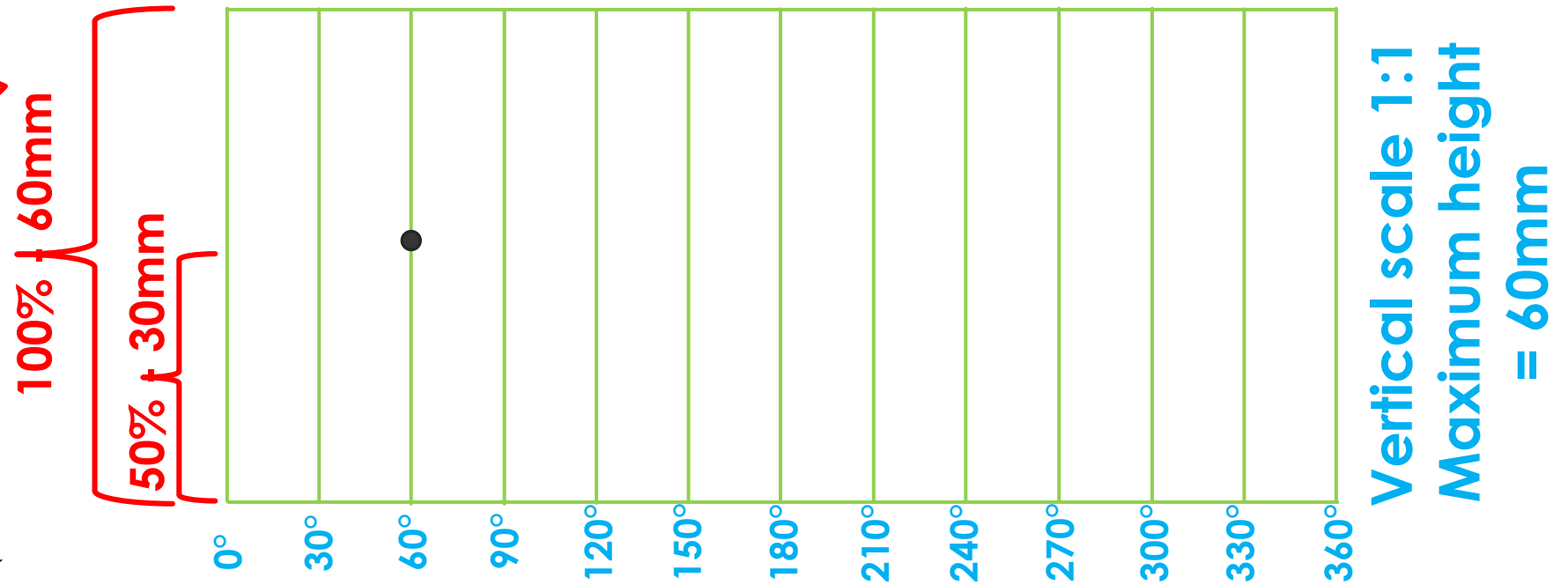

Displacement graph  
Scale 10mm = 30°

# Loci of a CAM

## By means of uniform motion

- $0^\circ$ - $60^\circ$ : Rise for 50%
- $60^\circ$ - $120^\circ$ : Rest
- $120^\circ$ - $180^\circ$ : Rise to maximum 60mm
- $180^\circ$ - $360^\circ$ : Back to original position

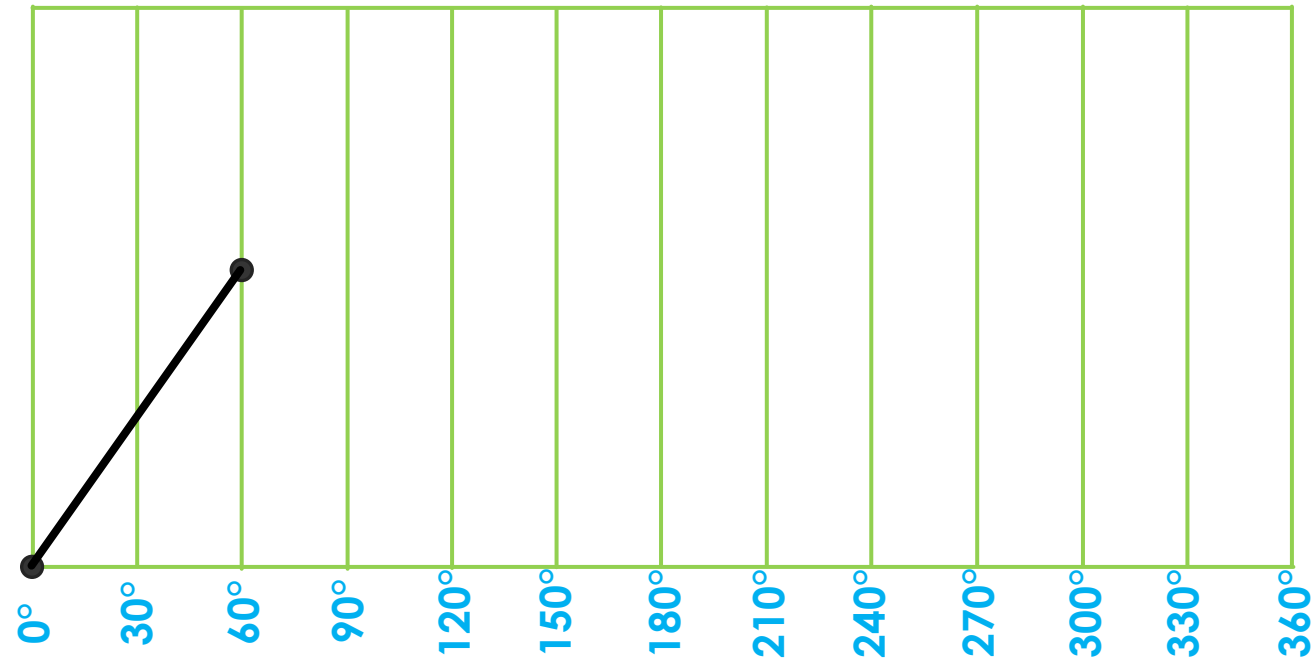

Displacement graph  
Scale 10mm =  $30^\circ$

Vertical scale 1:1

# Loci of a CAM

## By means of uniform motion

- $0^\circ$ - $60^\circ$ : Rise for 50%
- $60^\circ$ - $120^\circ$ : Rest
- $120^\circ$ - $180^\circ$ : Rise to maximum 60mm
- $180^\circ$ - $360^\circ$ : Back to original position

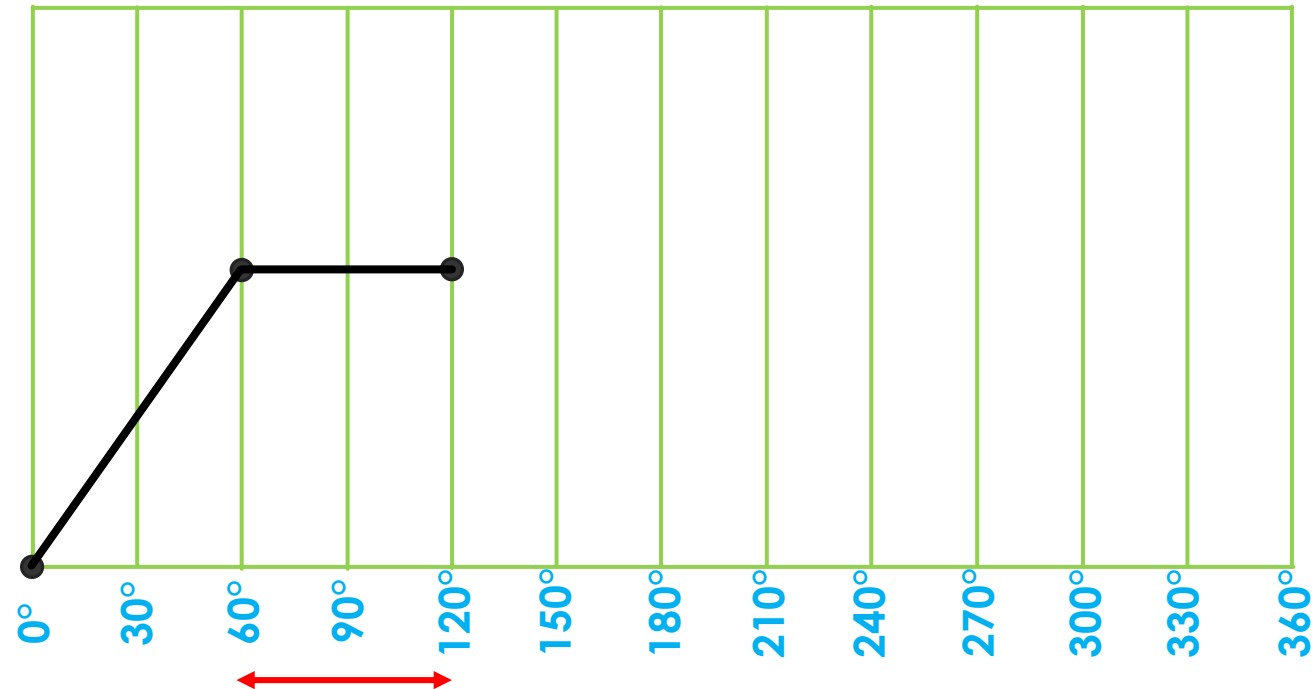

Displacement graph  
Scale 10mm =  $30^\circ$

Vertical scale 1:1

# Loci of a CAM

## By means of uniform motion

- $0^\circ$ - $60^\circ$ : Rise for 50%
- $60^\circ$ - $120^\circ$ : Rest
- $120^\circ$ - $180^\circ$ : Rise to maximum 60mm
- $180^\circ$ - $360^\circ$ : Back to original position

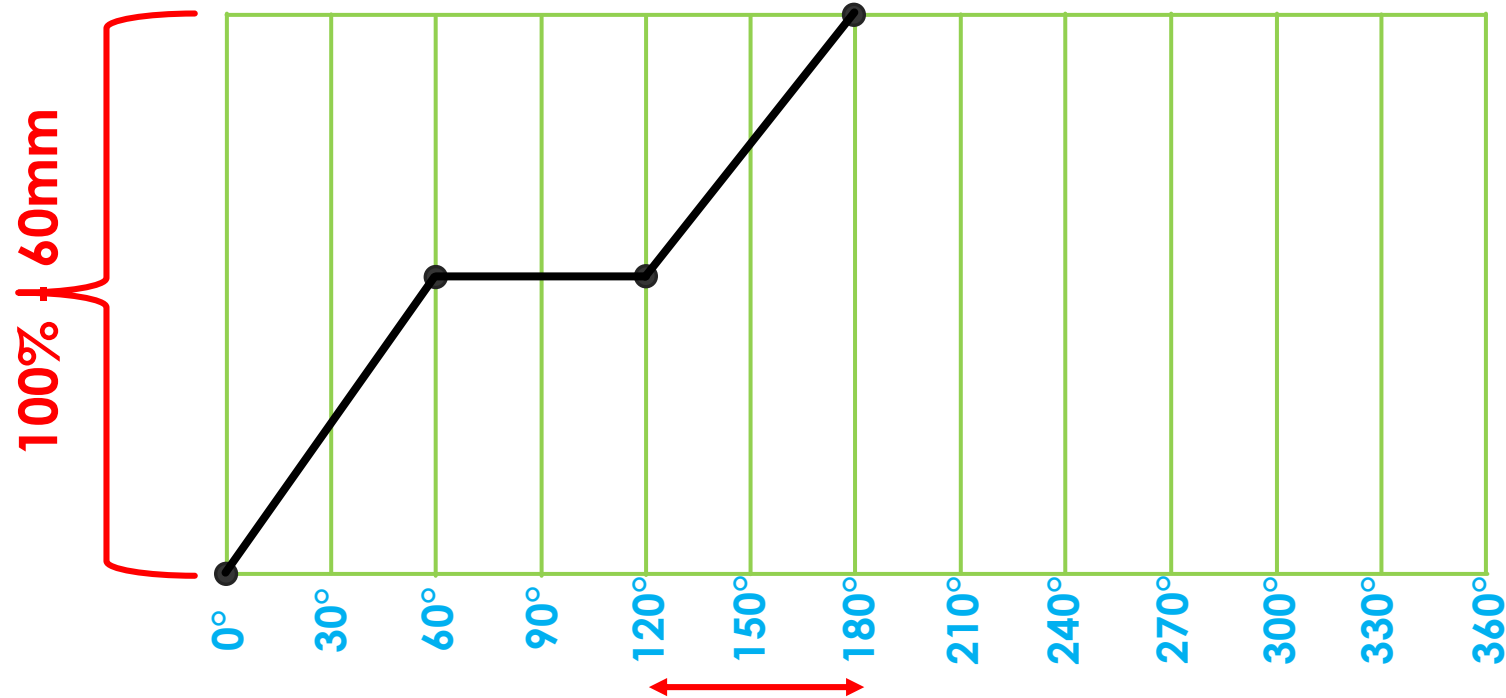

Displacement graph  
Scale 10mm =  $30^\circ$

Vertical scale 1:1

# Loci of a CAM

## By means of uniform motion

- $0^\circ$ - $60^\circ$ : Rise for 50%
- $60^\circ$ - $120^\circ$ : Rest
- $120^\circ$ - $180^\circ$ : Rise to maximum 60mm
- $180^\circ$ - $360^\circ$ : Back to original position

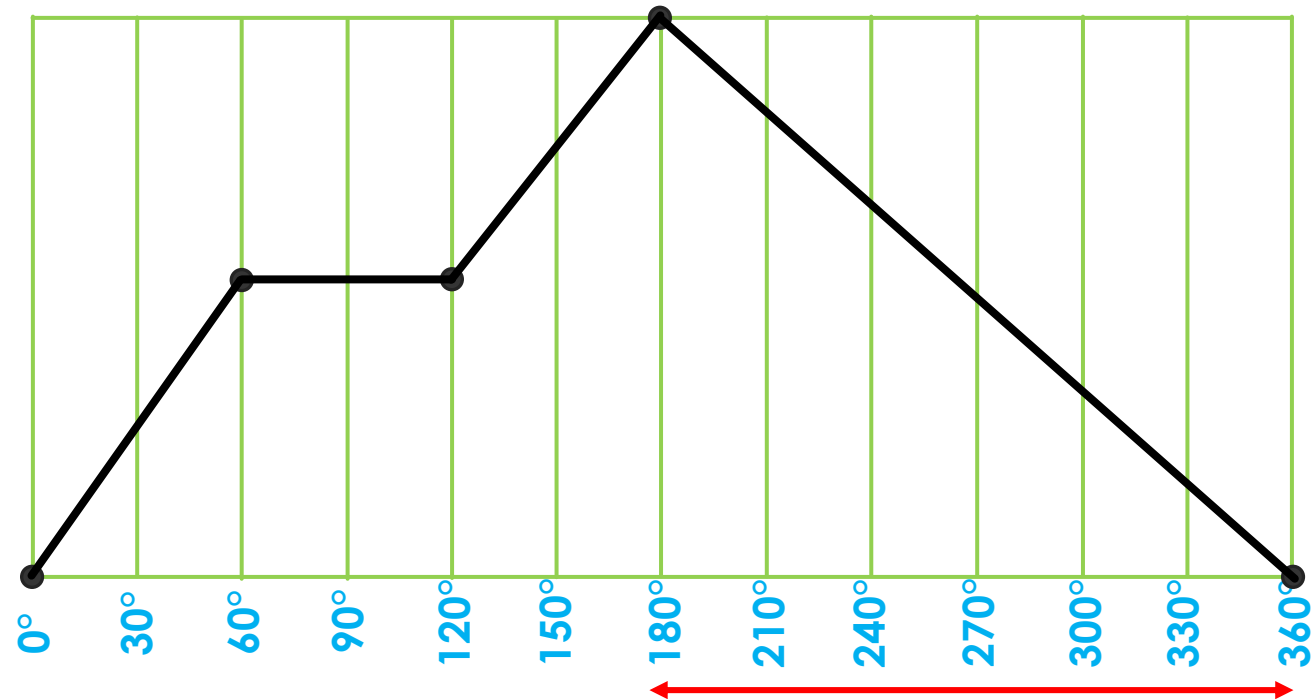

Displacement graph  
Scale 10mm =  $30^\circ$

Vertical scale 1:1

# Loci of a CAM

## By means of uniform motion

- $0^\circ$ - $60^\circ$ : Rise for 50%
- $60^\circ$ - $120^\circ$ : Rest
- $120^\circ$ - $180^\circ$ : Rise to maximum 60mm
- $180^\circ$ - $360^\circ$ : Back to original position

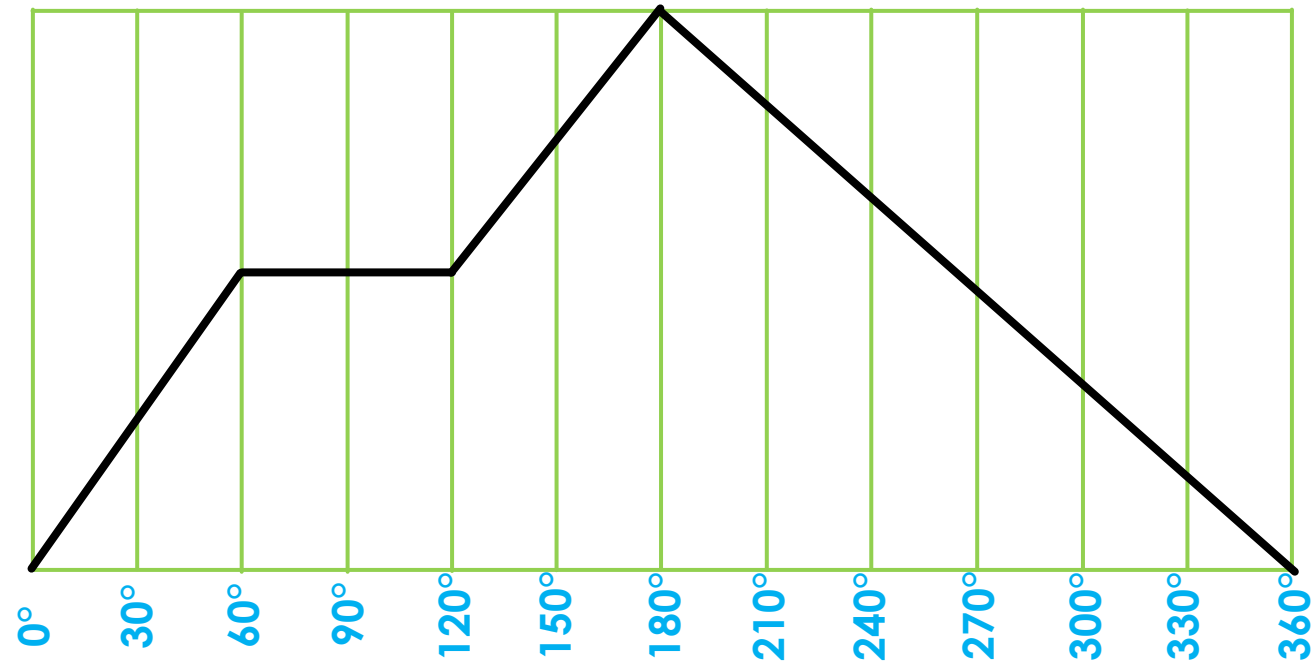

Displacement graph  
Scale 10mm =  $30^\circ$

Vertical scale 1:1

# Loci of a CAM

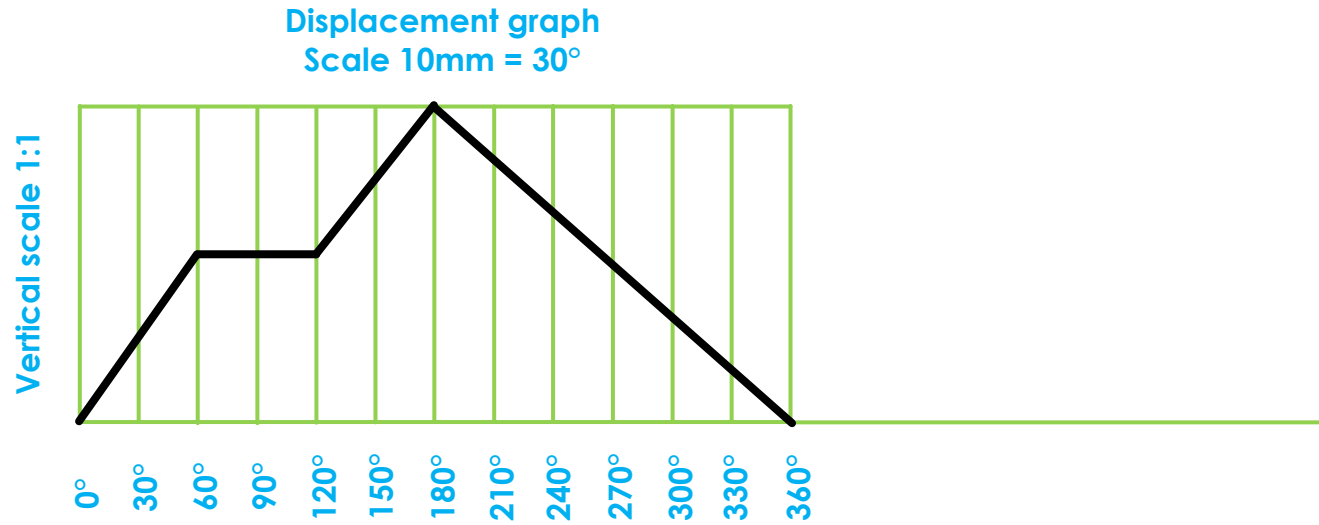

# Loci of a CAM: General information

- There might be smaller increments (normally  $15^\circ$ ) if more stages are required

# Loci of a CAM: General information

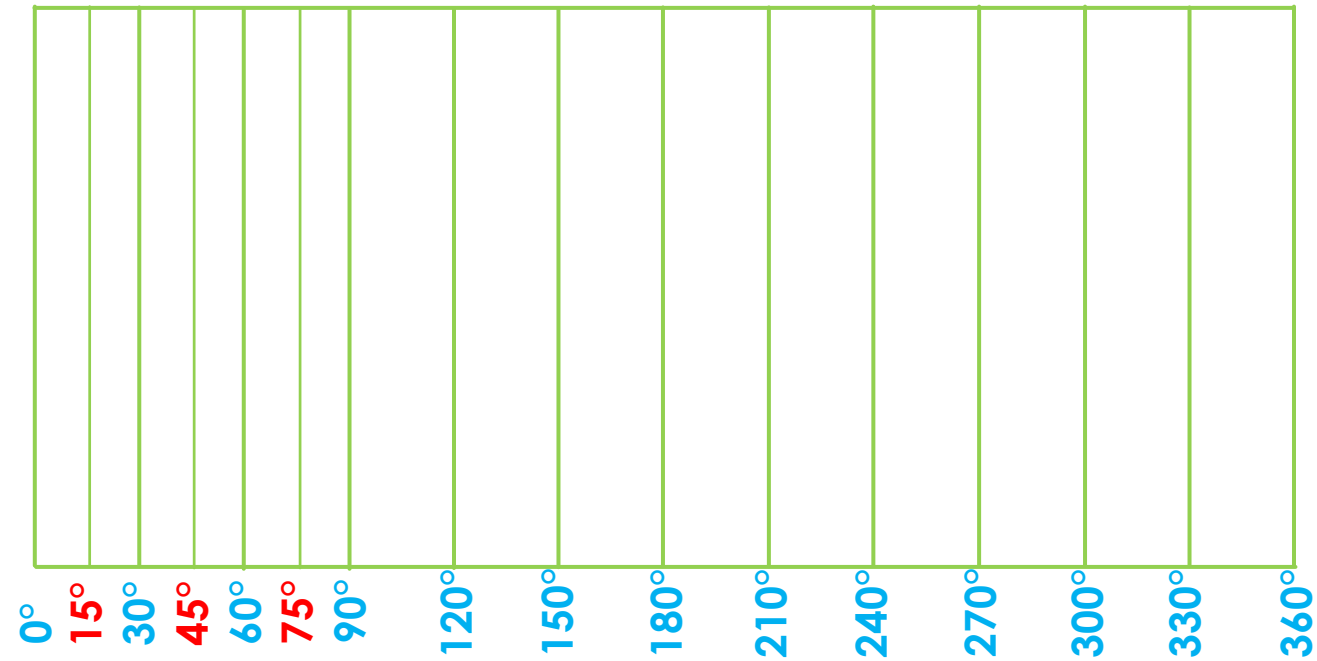

Vertical scale 1:1

Displacement graph  
Scale 10mm = 30°

# Loci of a CAM: UNIFORM MOVEMENT

## By means of uniform motion

- $0^\circ$ - $45^\circ$ : Rise with 50mm
- $45^\circ$ - $135^\circ$ : Rise to maximum of 70mm
- $135^\circ$ - $270^\circ$ : Rest
- $270^\circ$ - $360^\circ$ : Back to original position

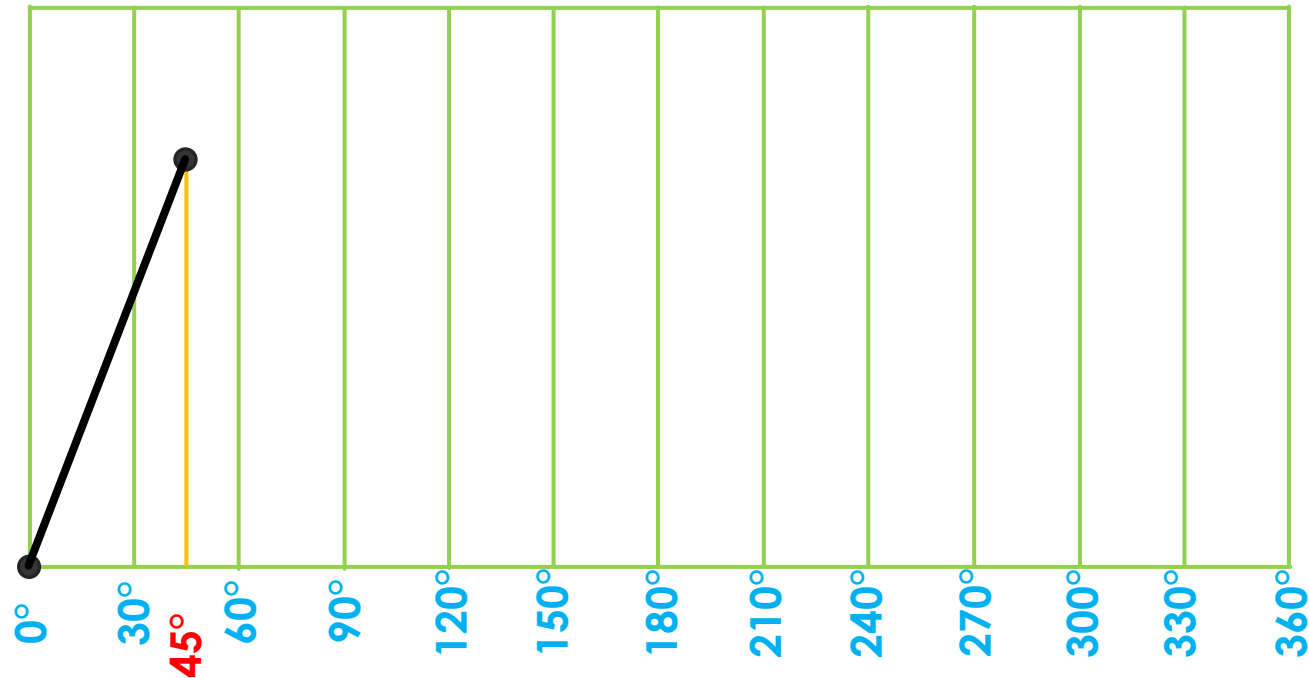

Displacement graph  
Scale 10mm =  $30^\circ$

Vertical scale 1:1

# Loci of a CAM: UNIFORM MOVEMENT

## By means of uniform motion

- $0^\circ$ - $45^\circ$ : Rise with 50mm
- $45^\circ$ - $135^\circ$ : Rise to maximum of 70mm
- $135^\circ$ - $270^\circ$ : Rest
- $270^\circ$ - $360^\circ$ : Back to original position

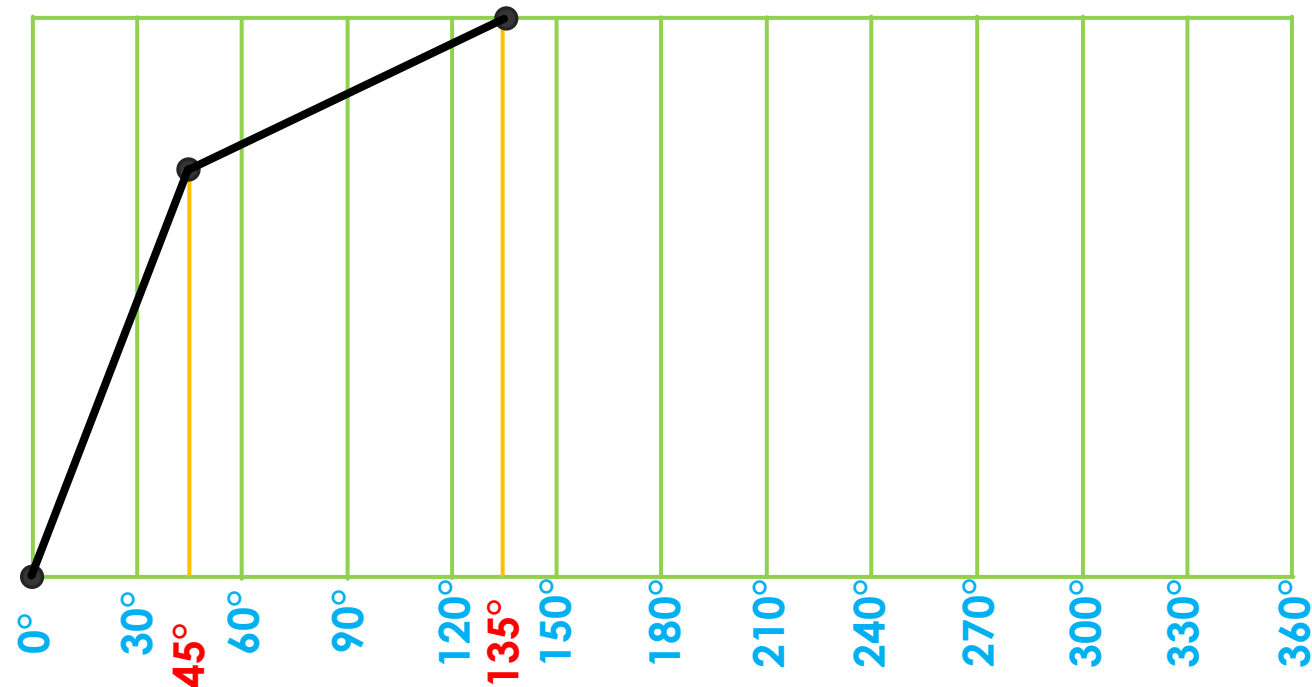

Displacement graph  
Scale 10mm =  $30^\circ$

Vertical scale 1:1

# Loci of a CAM: UNIFORM MOVEMENT

## By means of uniform motion

- $0^\circ$ - $45^\circ$ : Rise with 50mm
- $45^\circ$ - $135^\circ$ : Rise to maximum of 70mm
- $135^\circ$ - $270^\circ$ : Rest
- $270^\circ$ - $360^\circ$ : Back to original position

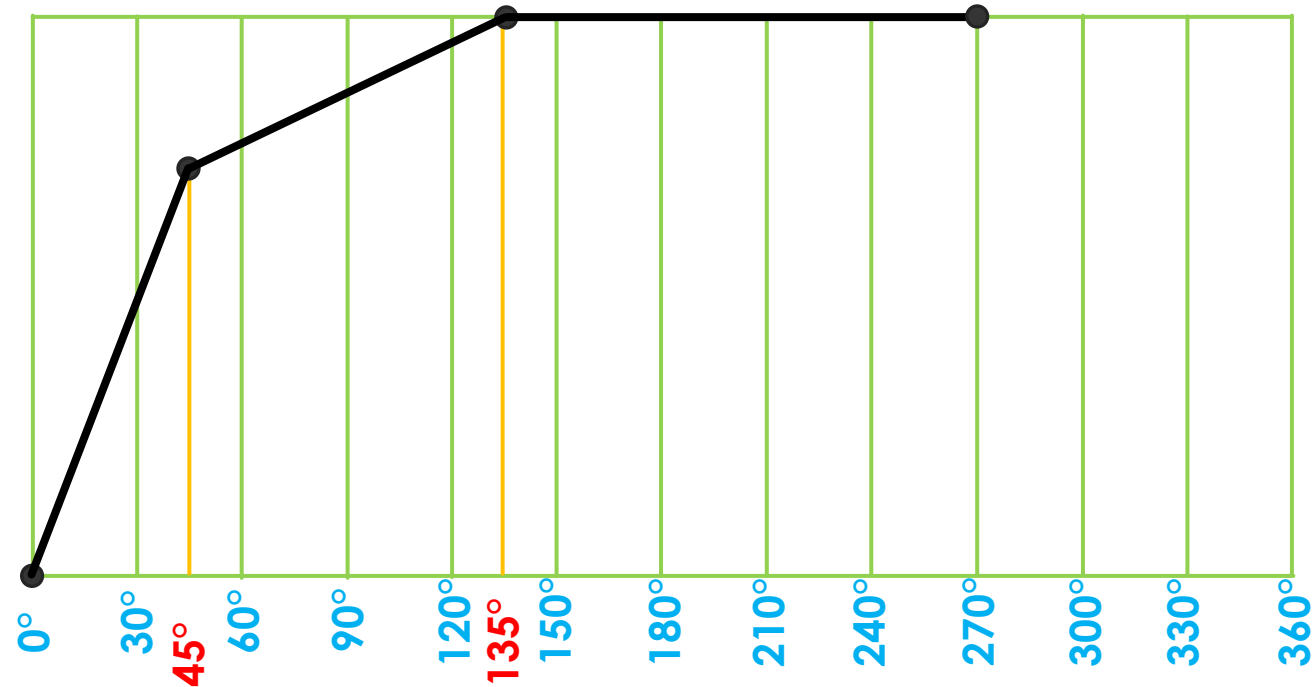

Displacement graph  
Scale 10mm = 30°

Vertical scale 1:1

# Loci of a CAM: UNIFORM MOVEMENT

## By means of uniform motion

- $0^\circ$ - $45^\circ$ : Rise with 50mm
- $45^\circ$ - $135^\circ$ : Rise to maximum of 70mm
- $135^\circ$ - $270^\circ$ : Rest
- $270^\circ$ - $360^\circ$ : Back to original position

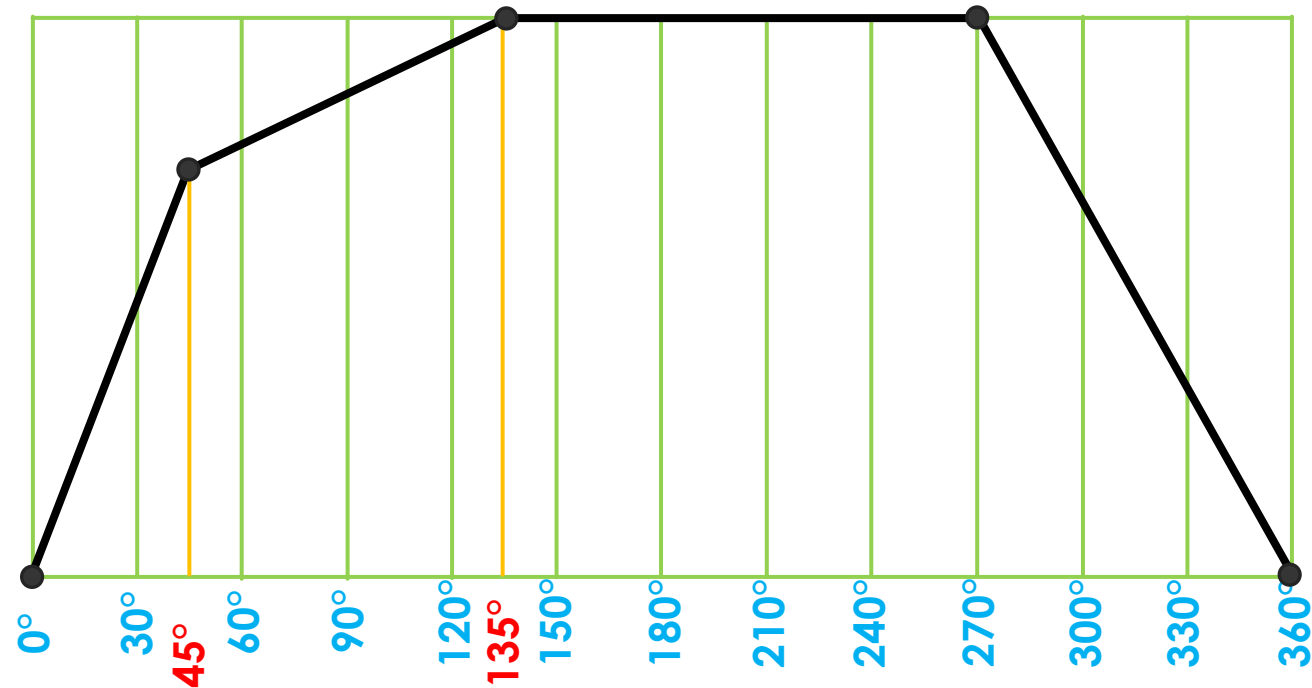

Displacement graph  
Scale 10mm =  $30^\circ$

Vertical scale 1:1