



Principles of Mechanical Drawings – CONSTRUCTION OF A LOCKNUT

Developed by: PC Viljoen
Senior Educational Specialist for
Engineering Graphics and Design
Free State Province

Construction of a LOCKNUT

- The **outer diameter** of the bolt/stud will determine all the dimensions of the **locknut** and **bolt**

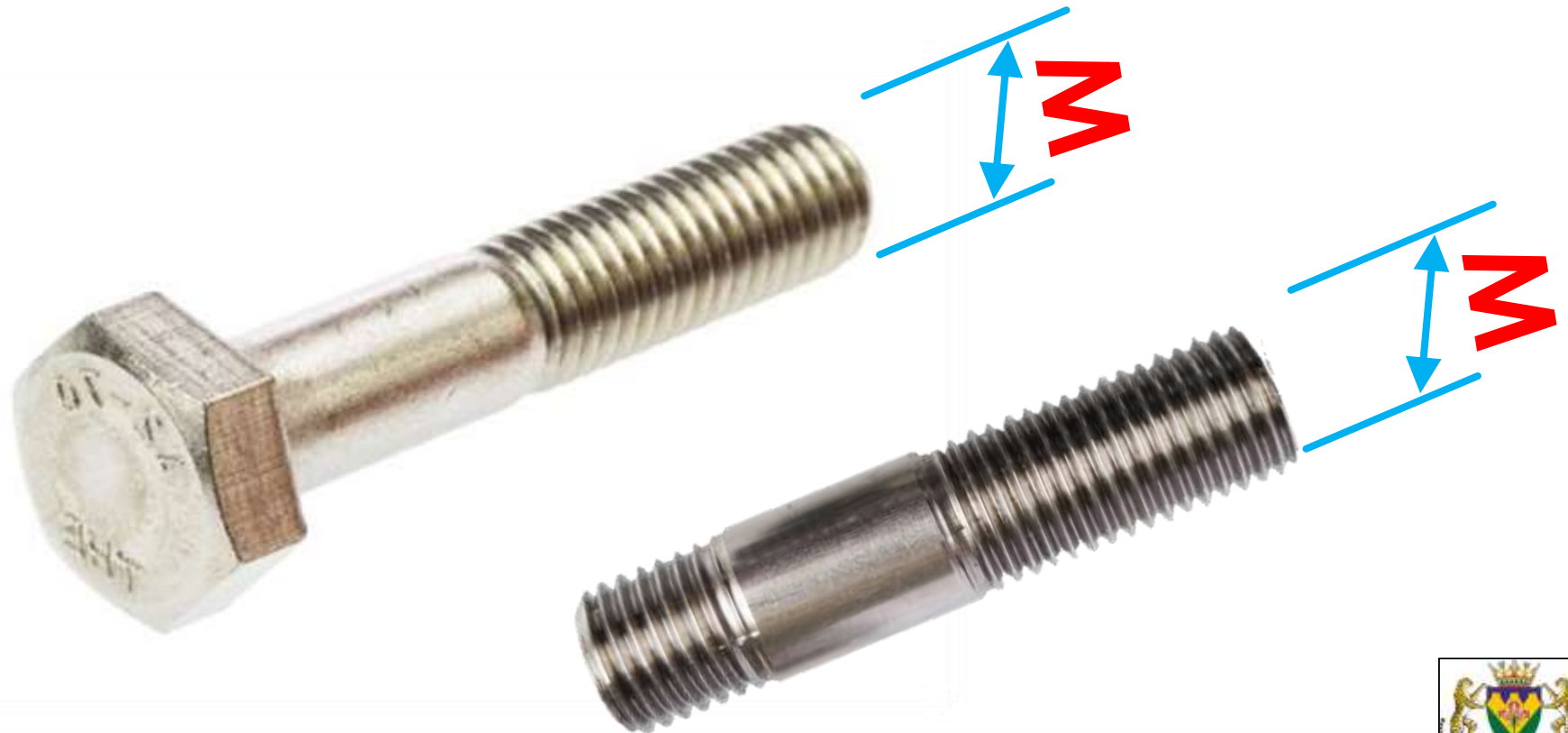

Construction of a LOCKNUT

- General terminology
 - **ACROSS FLAT (AF)**
 - The **AF** will always be **1,5 of diameter**

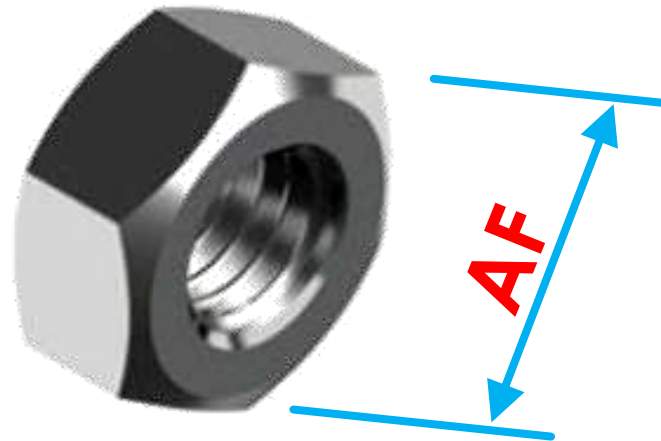

Construction of a LOCKNUT

- General terminology
 - **THICKNESS OF THE LOCKNUT (T)**
 - The thickness of the **locknut (T)** will always be **0,5 of diameter T**

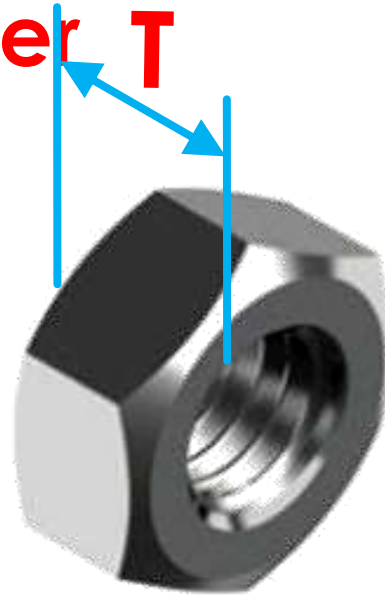

Construction of a LOCKNUT

- The **thread size M**
- The thickness of the **thread (M)** will always be **0,1 of diameter**

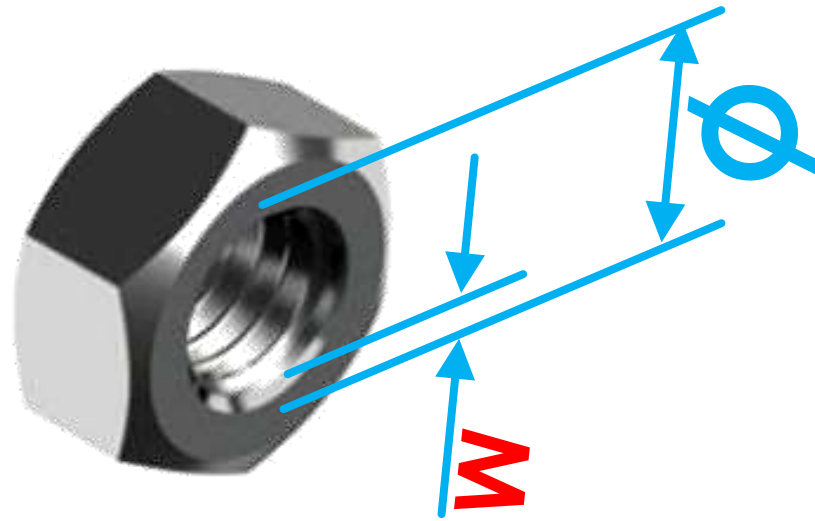

Construction of a LOCKNUT

- ▶ When constructing a nut, **always** determine the true shape first.

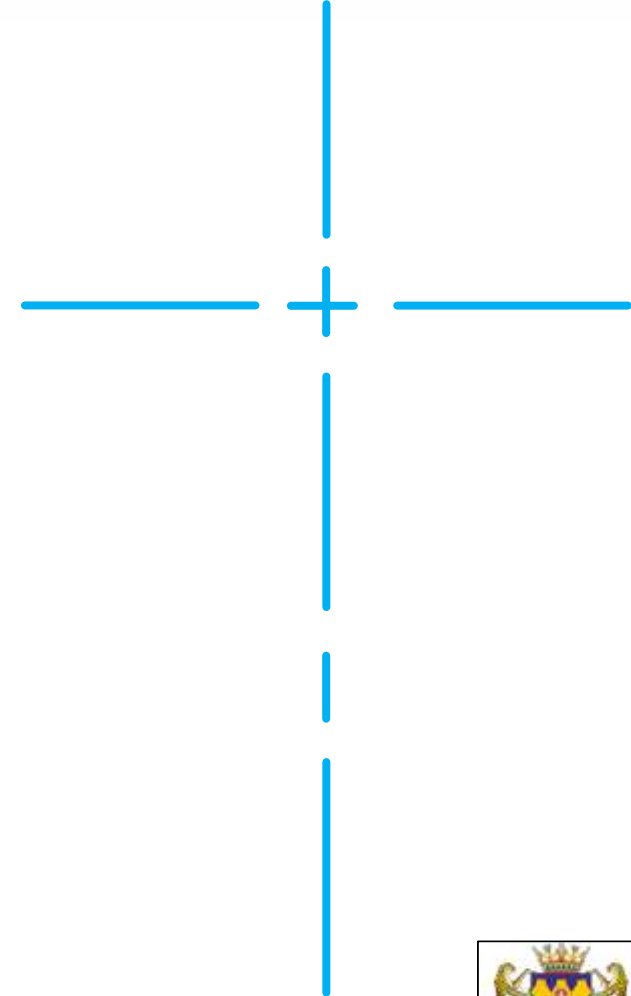
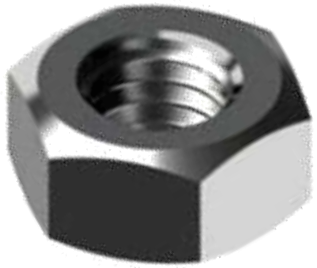

Construction of a LOCKNUT

► Use diameter (18mm) to determine the across flat (1,5) of the hexagon.

► = **M X scale factor**

► = **18 X 1,5**

► = **27**

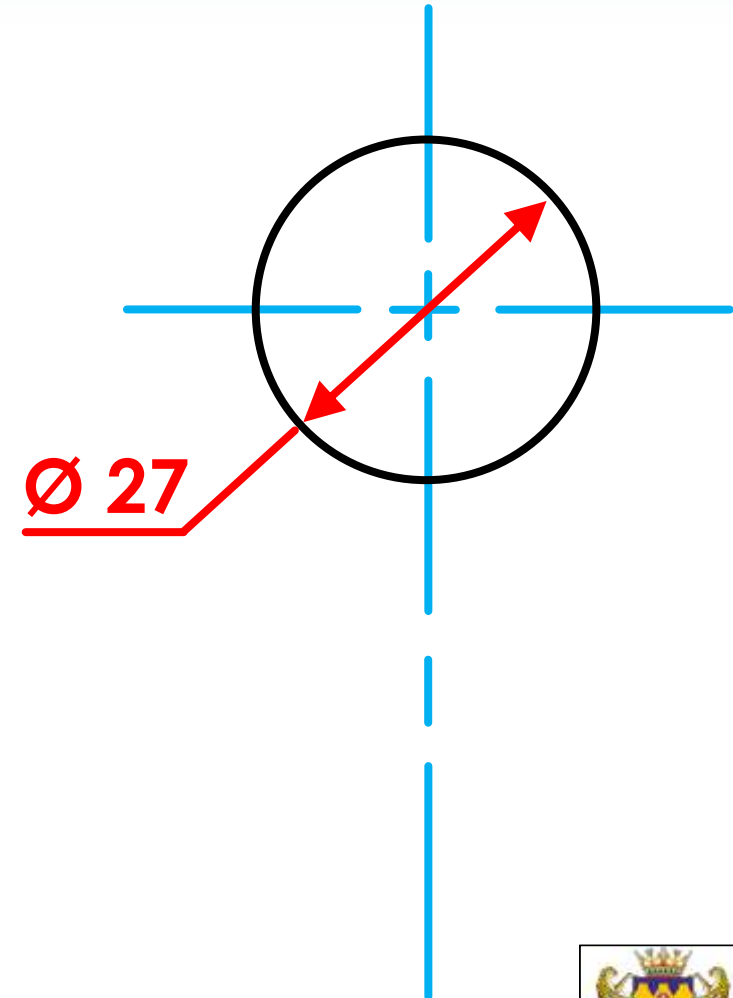
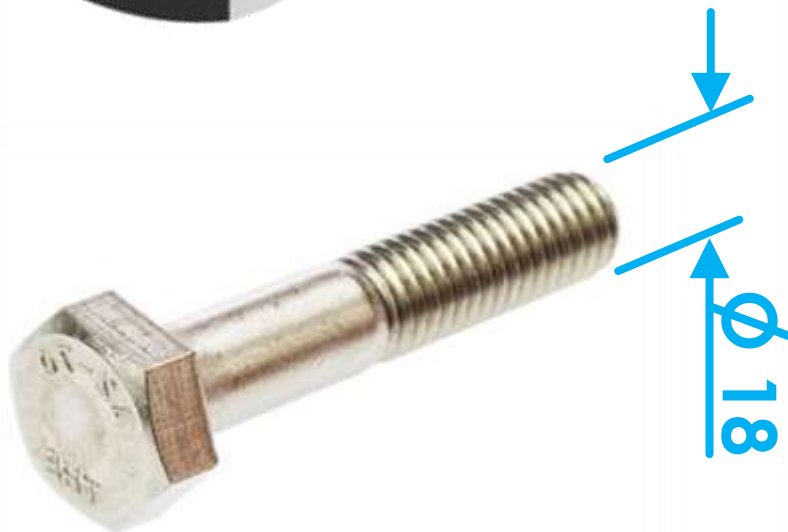
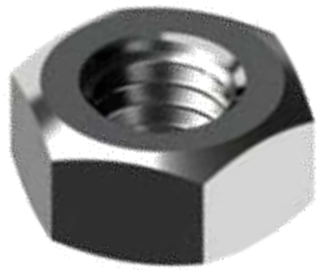

Construction of a LOCKNUT

- Construct an external tangent hexagon around the circle to indicate the outer portion of the locknut.

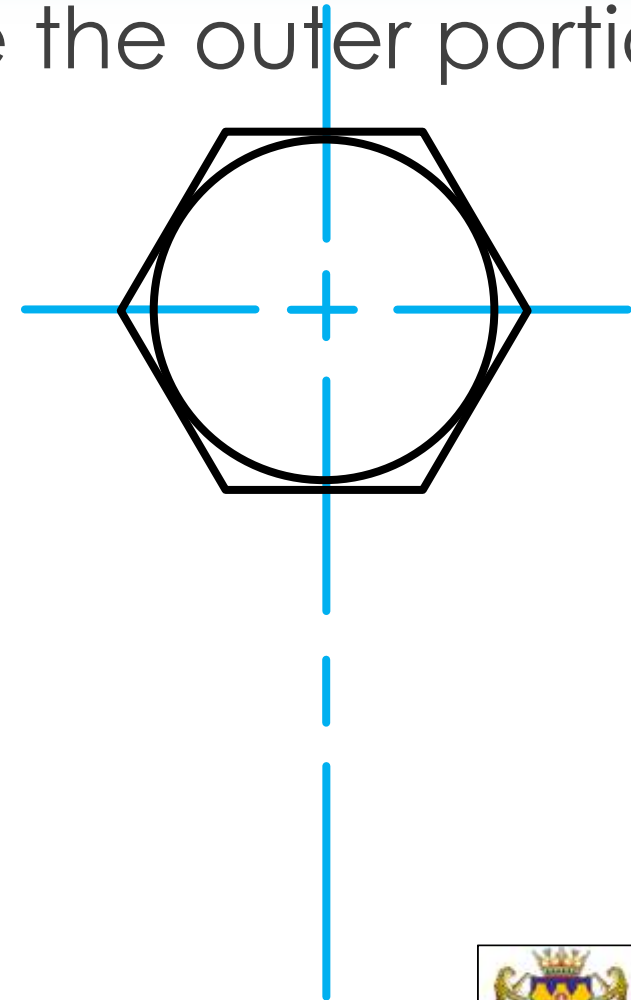
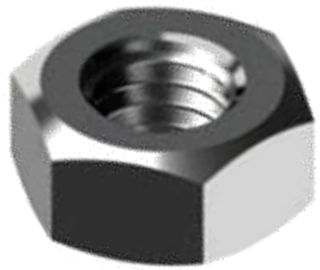

Construction of a LOCKNUT

- Since the diameter will not be visible, indicate the **diameter (18mm)** by means of an incomplete circle (B-line type).

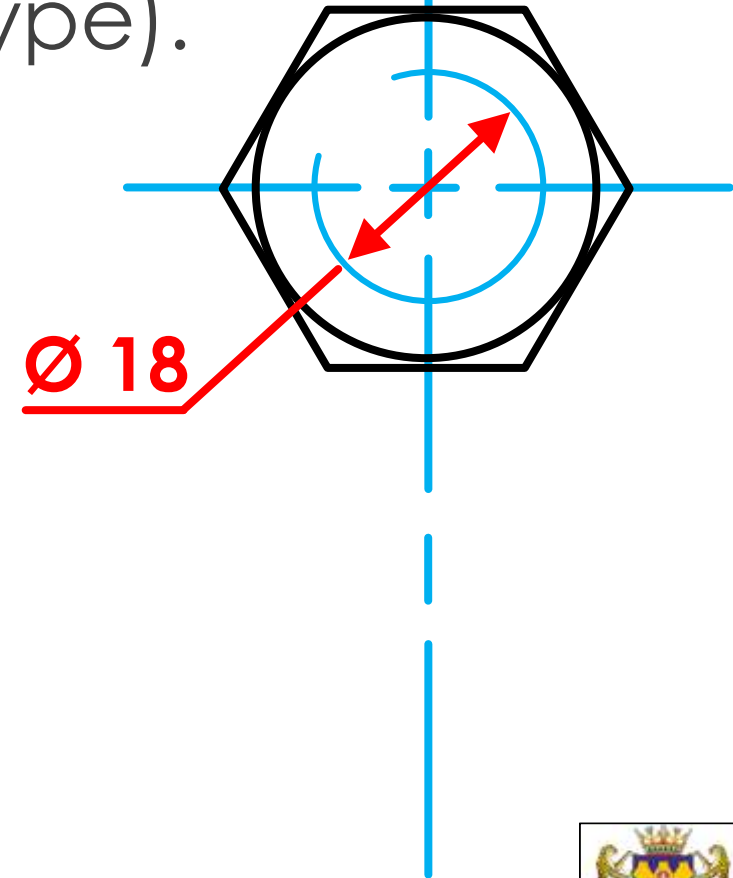
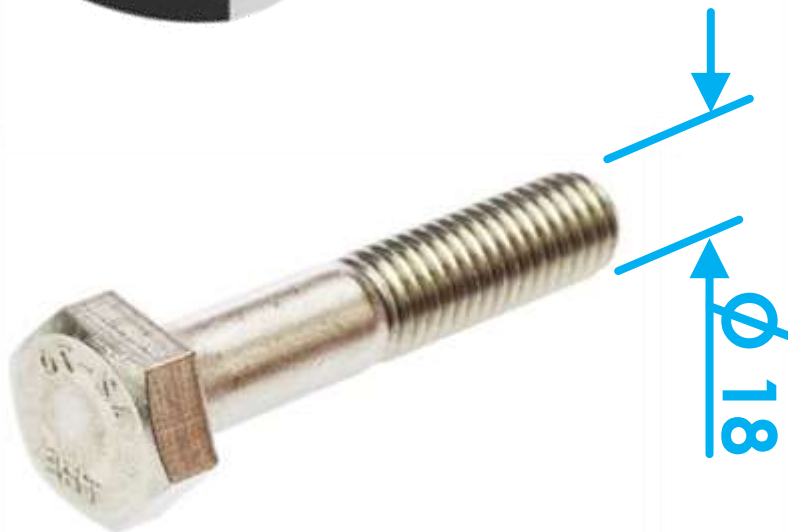
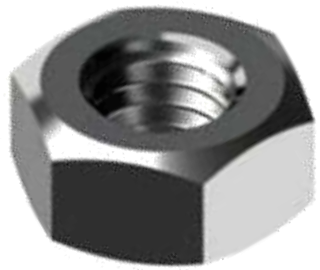

Construction of a LOCKNUT

► Indicate the inner thread by means of a solid circle.

► = **M X scale factor**

► = **18 X 0,1**

► = **1,8mm**

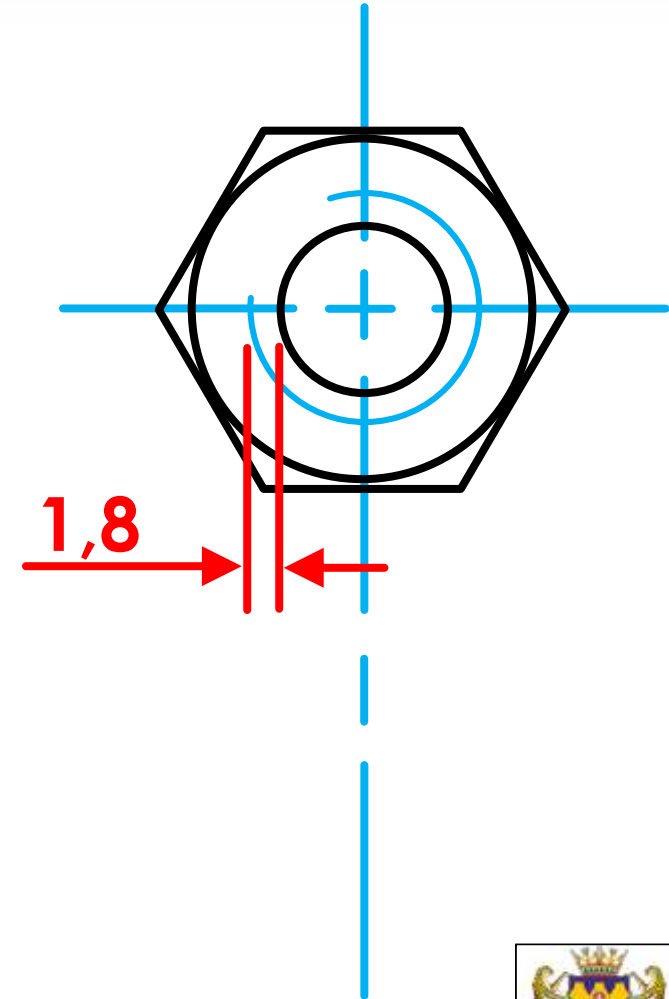
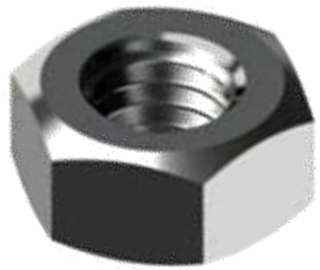

Construction of a LOCKNUT

- Determine the front view start position of the locknut.

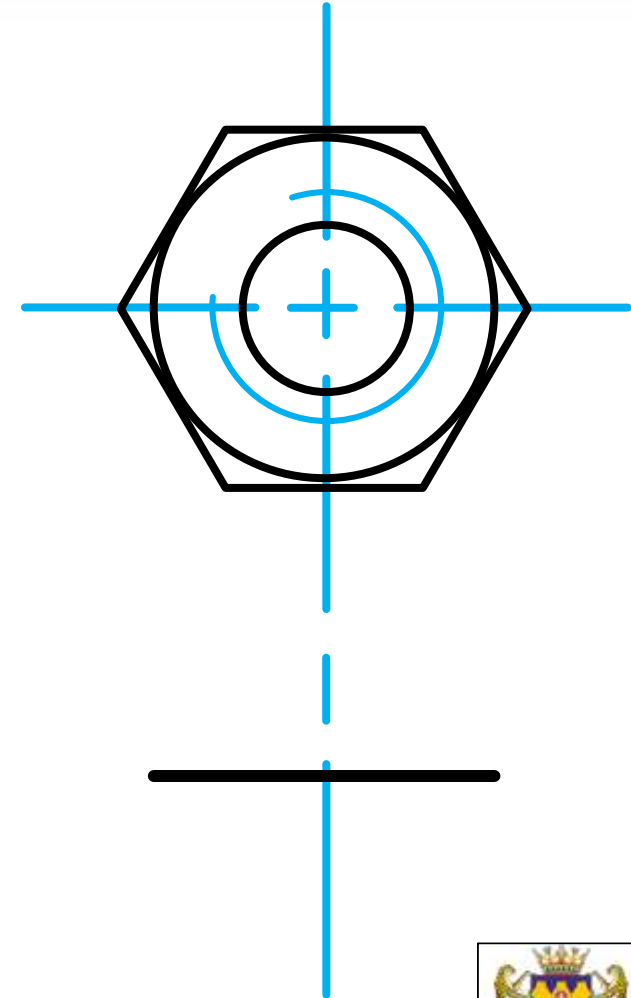
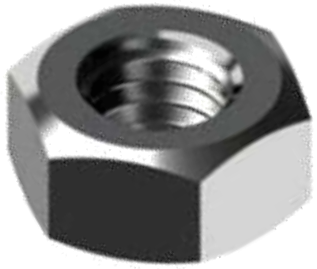

Construction of a NUT

► Determine the thickness of the nut.

► = $M \times 0,5$

► = $18 \times 0,5$

► = 9

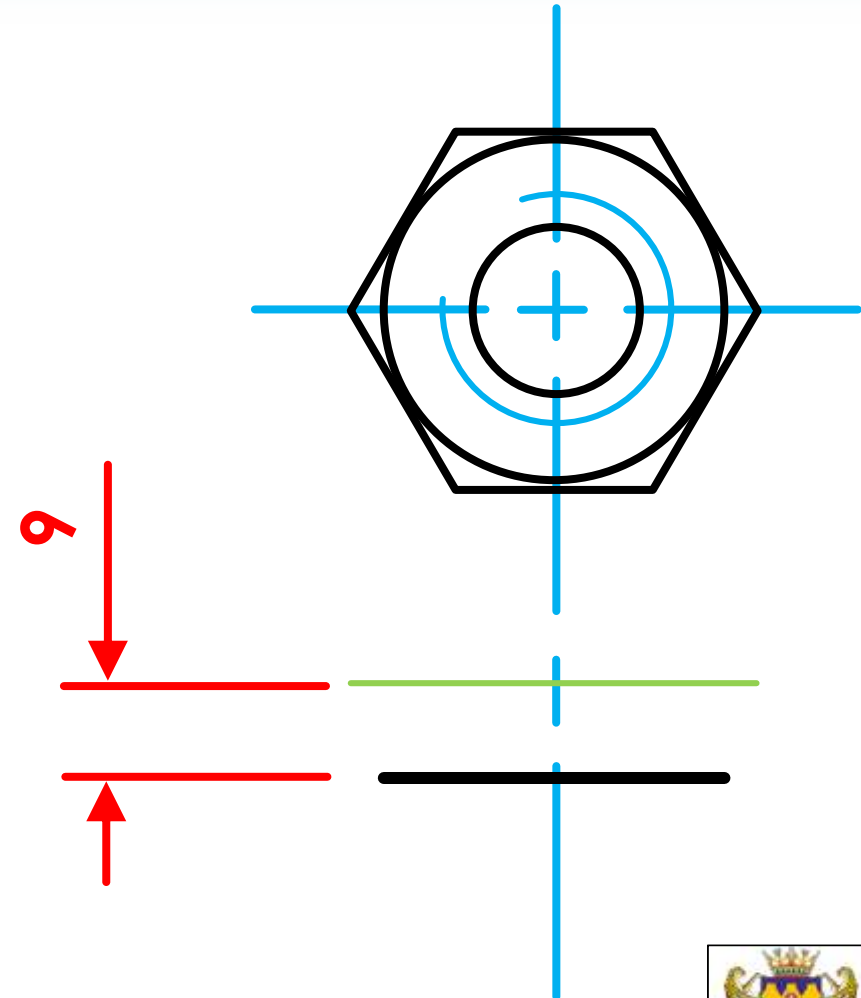
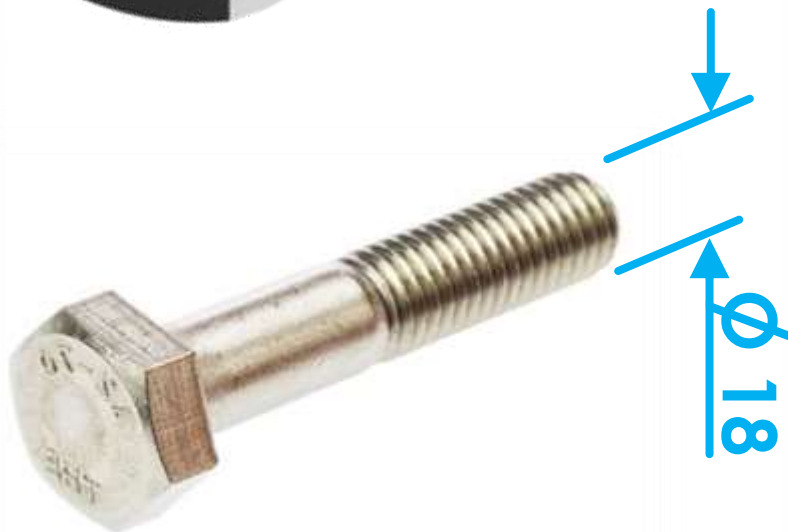
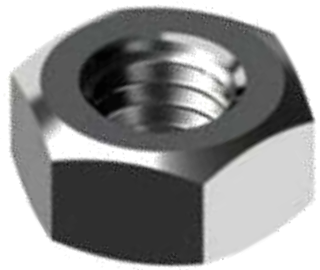

Construction of a NUT

- Project the front view from the true shape of the nut

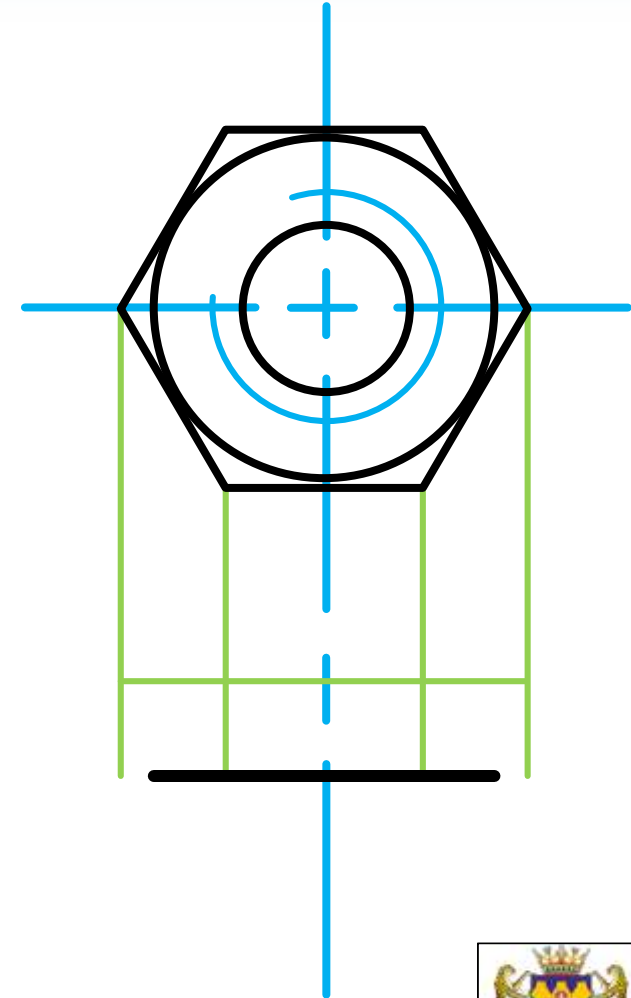
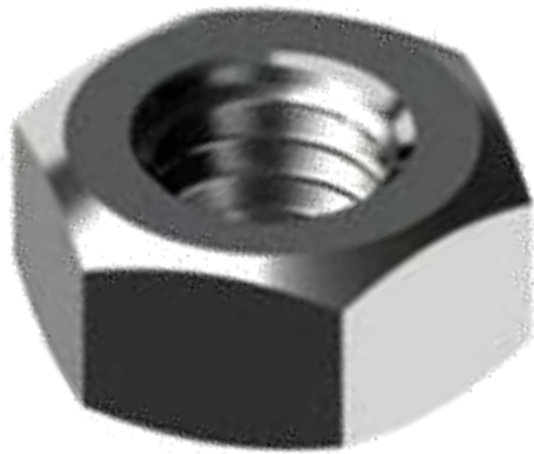

Construction of a NUT

- Determine the intersection point for the upper arc at 60° .

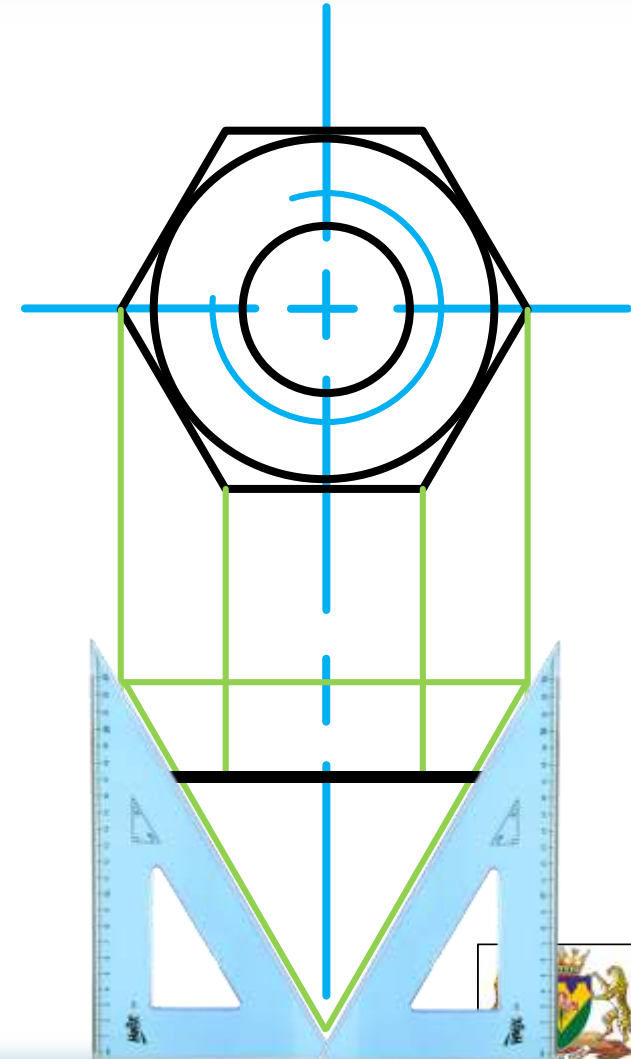
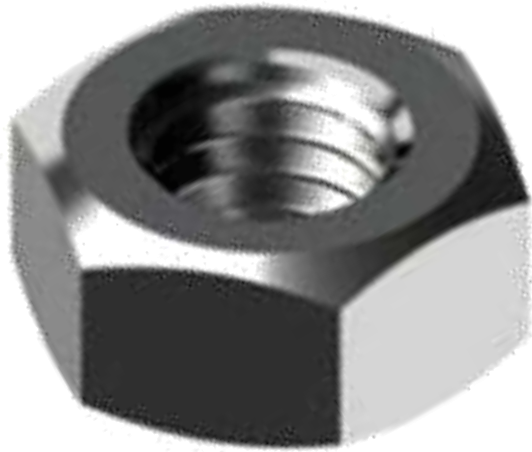

Construction of a NUT

- Construct the upper arc.

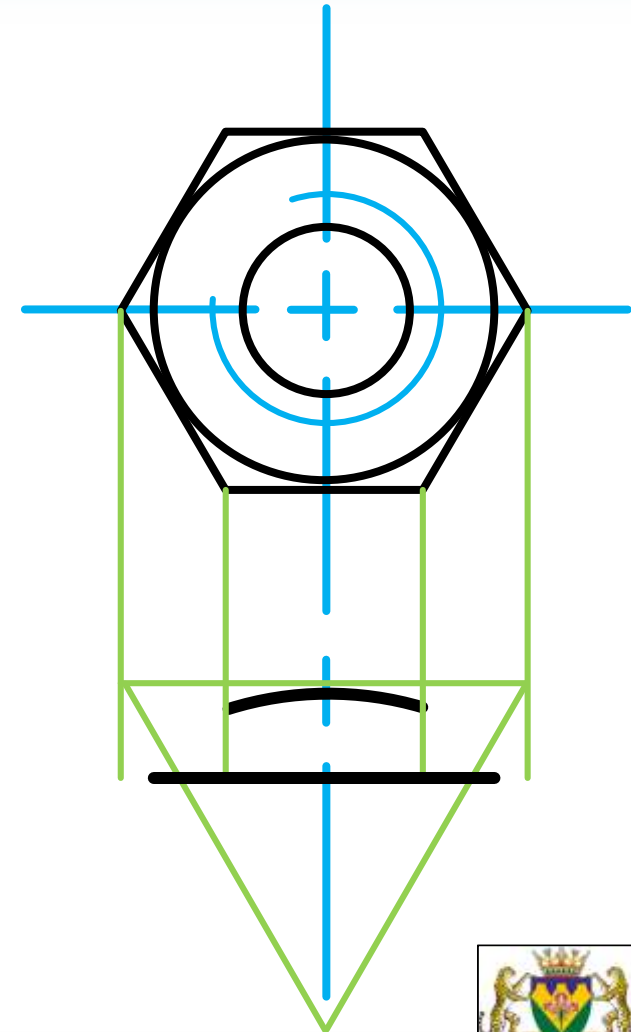
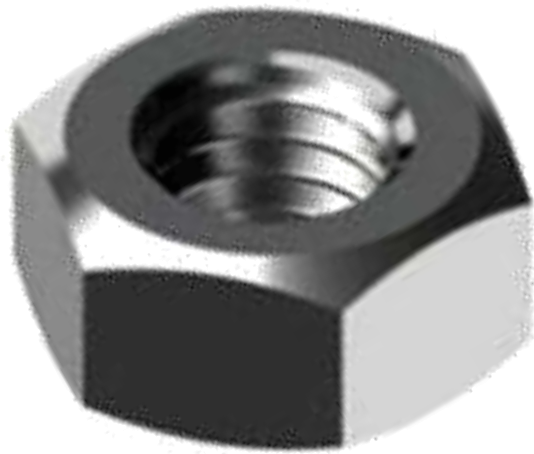

Construction of a NUT

- Determine the intersection point for the remaining smaller upper arcs at 60° .

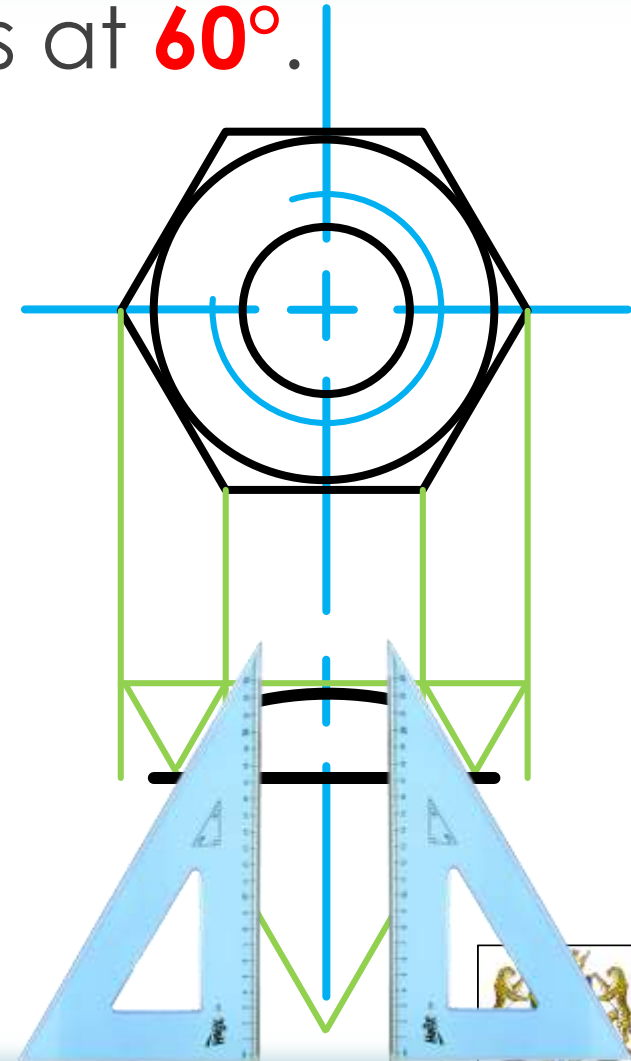
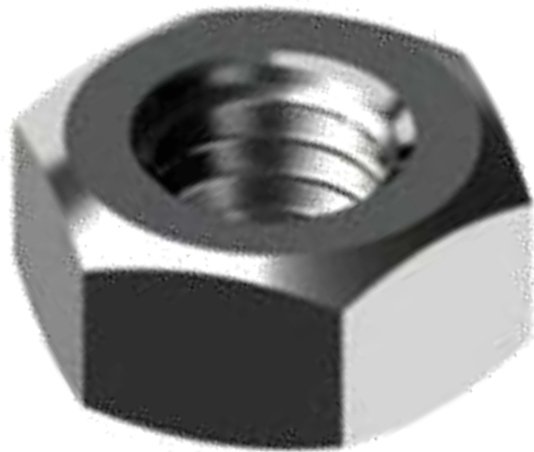

Construction of a NUT

- Construct the smaller upper arcs.

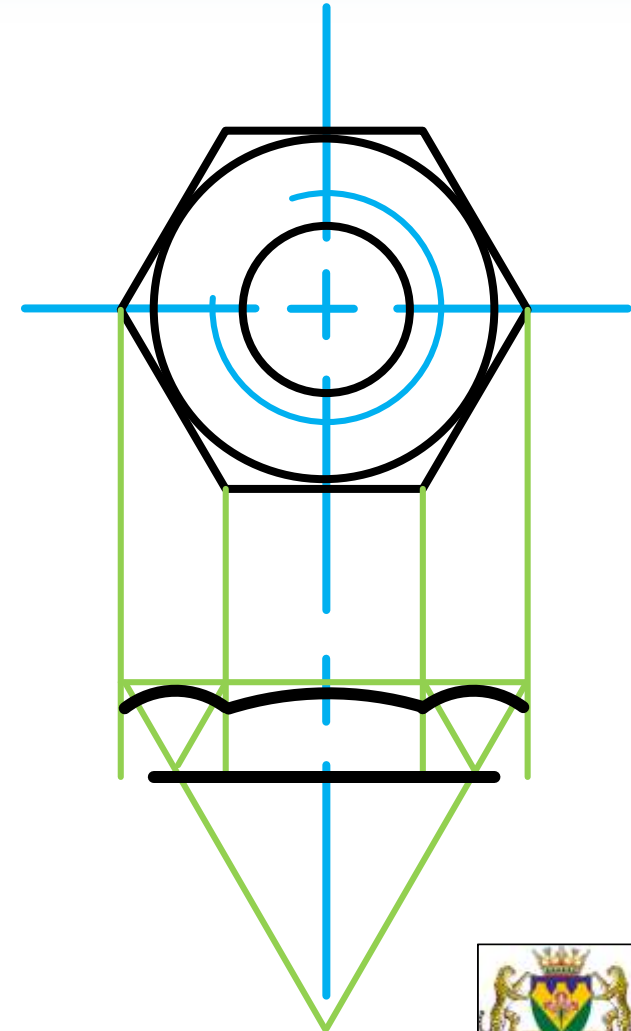
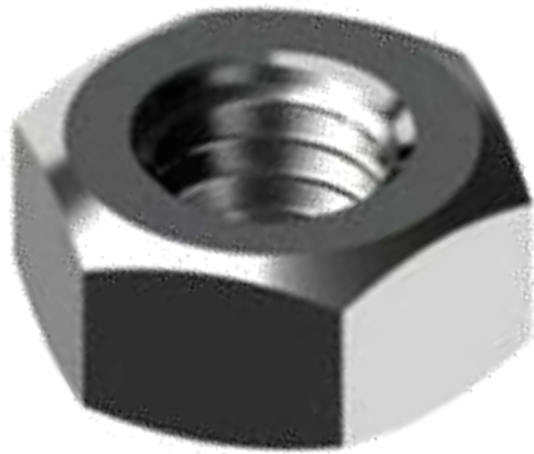

Construction of a NUT

- Construct the lower arcs.

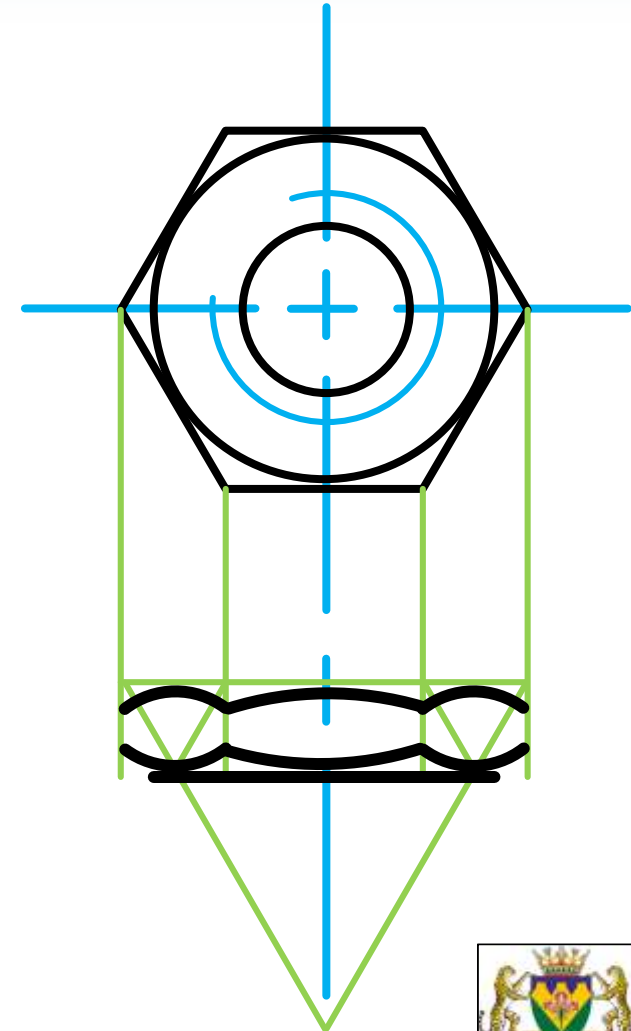
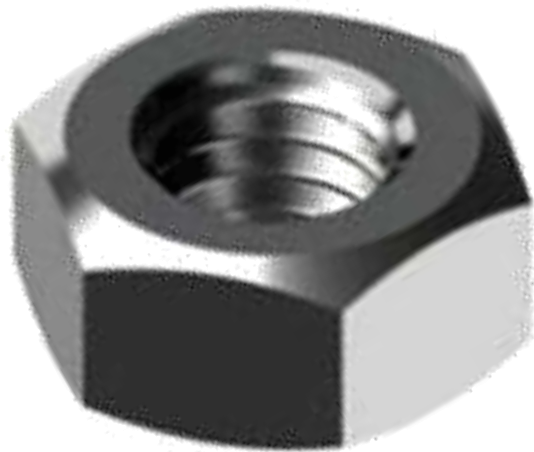

Construction of a NUT

- Join the endpoints of each arc with the opposite corresponding arc.

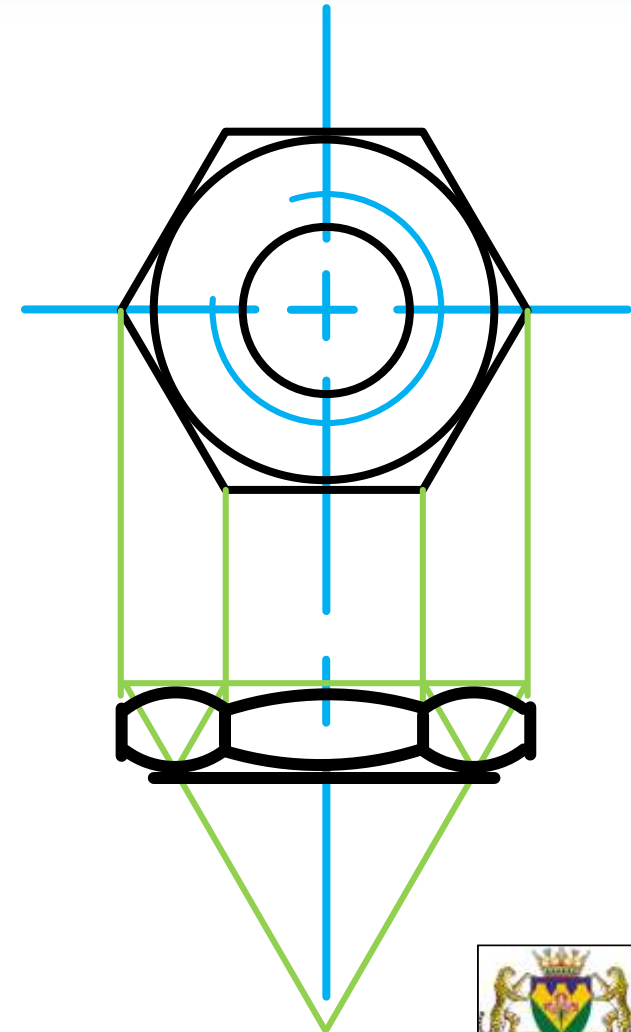
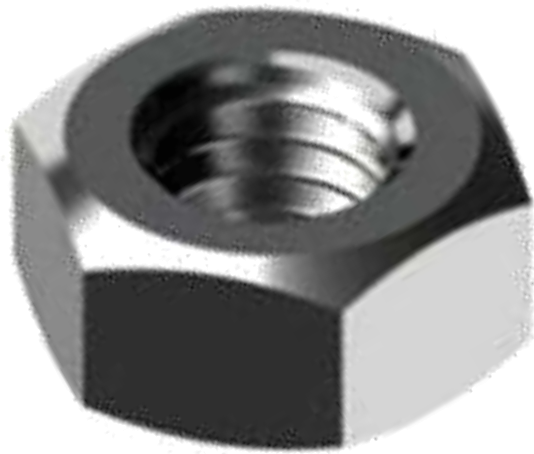

Construction of a NUT

- Chamfer (bevel the edges) the nut endpoints on **30°**.

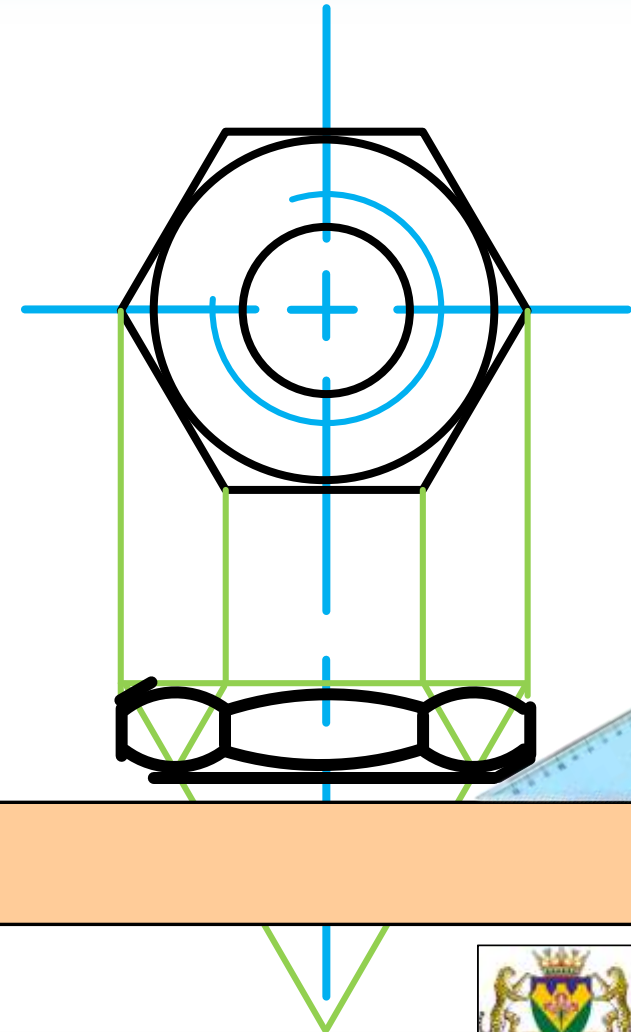
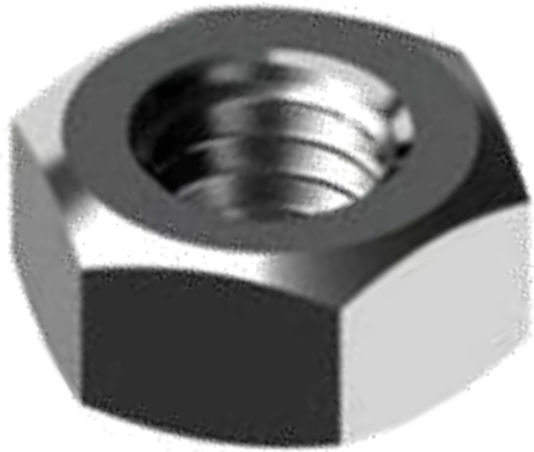

Construction of a NUT

- Chamfer (bevel the edges) the nut endpoints on **30°**.

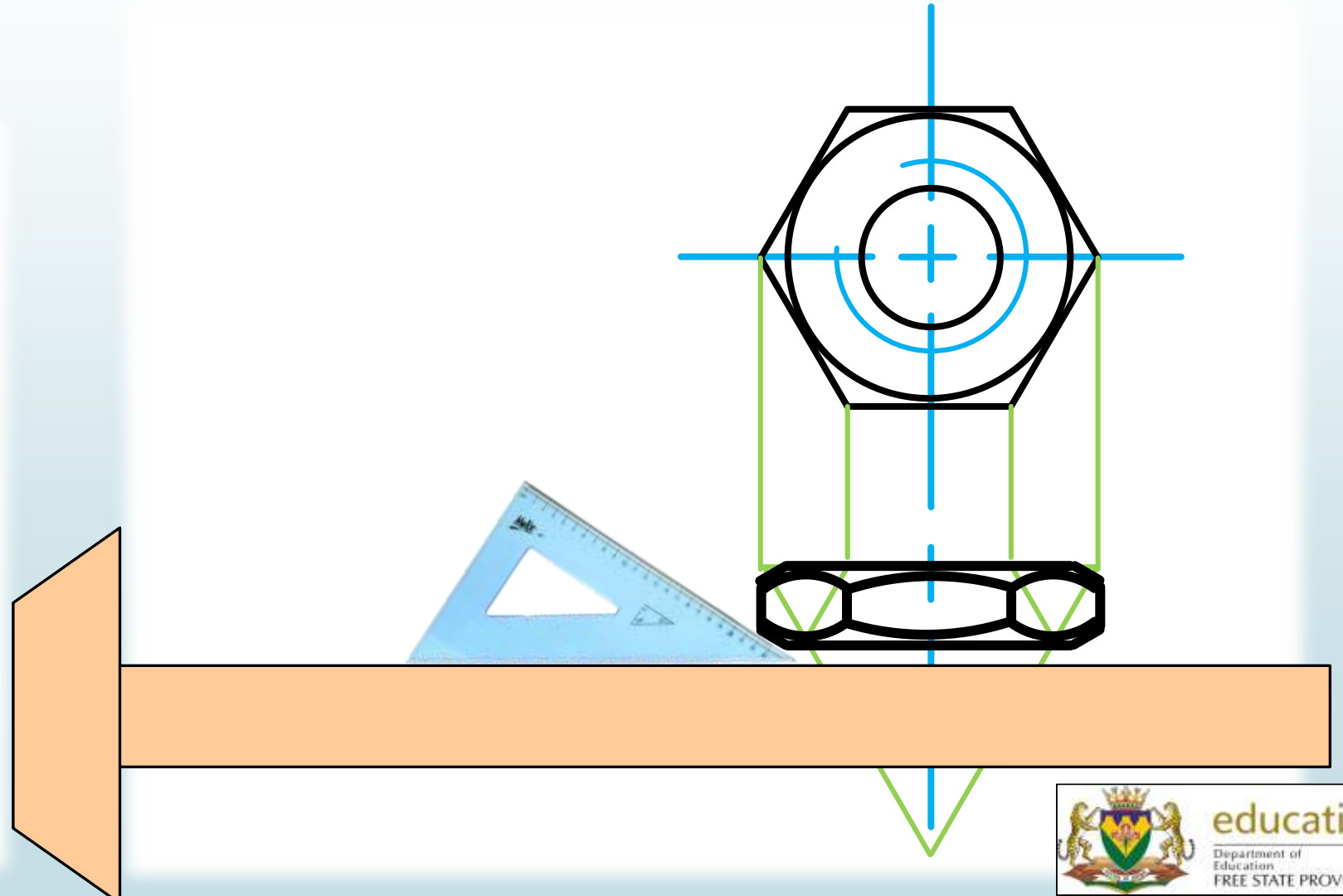
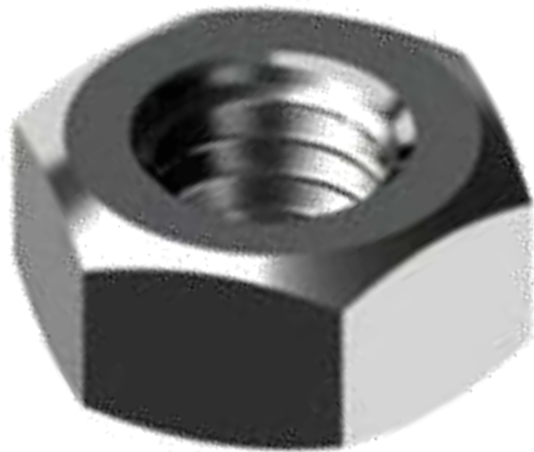

Construction of a NUT

- Project the left view from the true shape and front view.

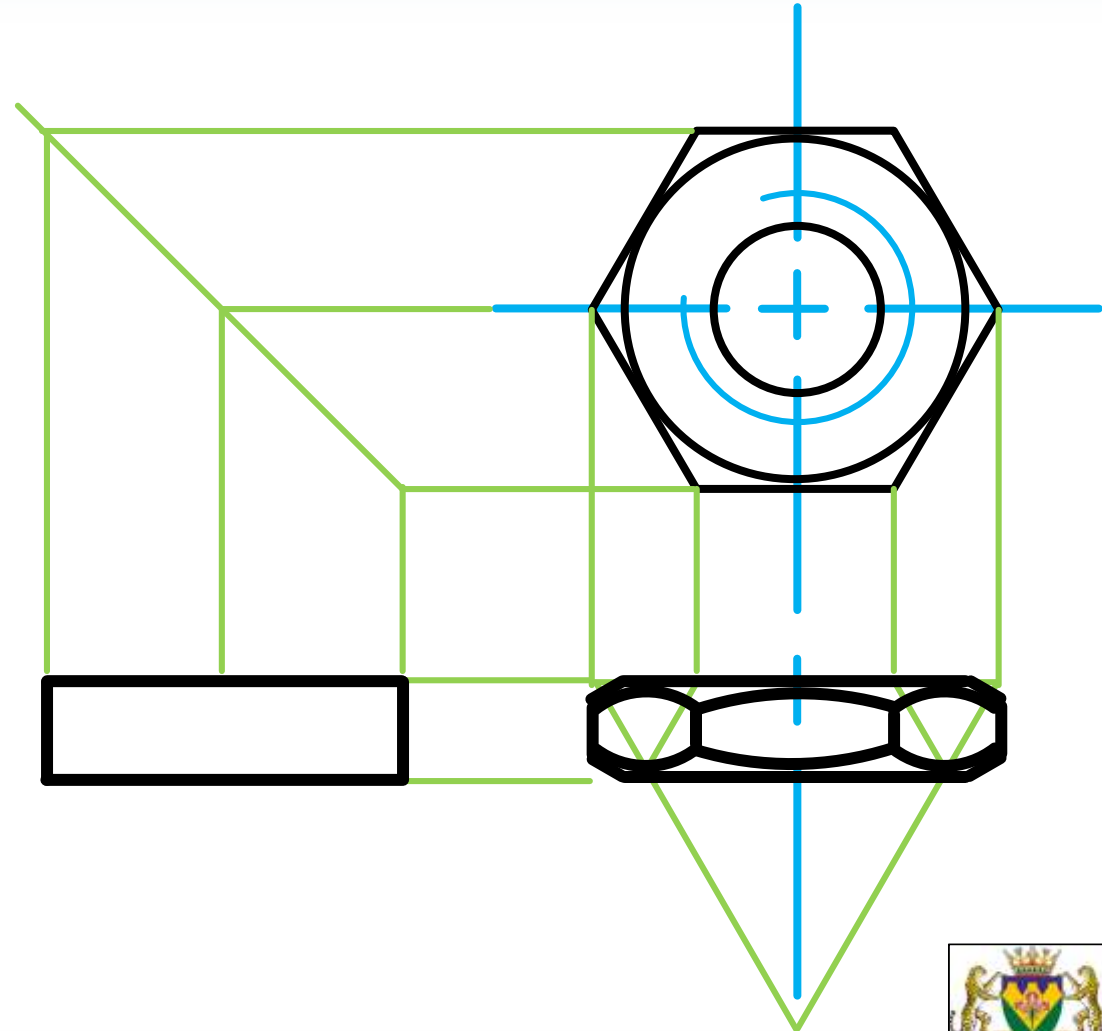
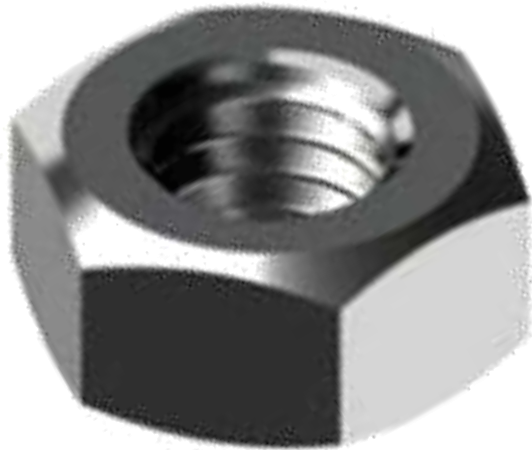

Construction of a NUT

- Determine the intersection point for the upper arcs at 60° point of..

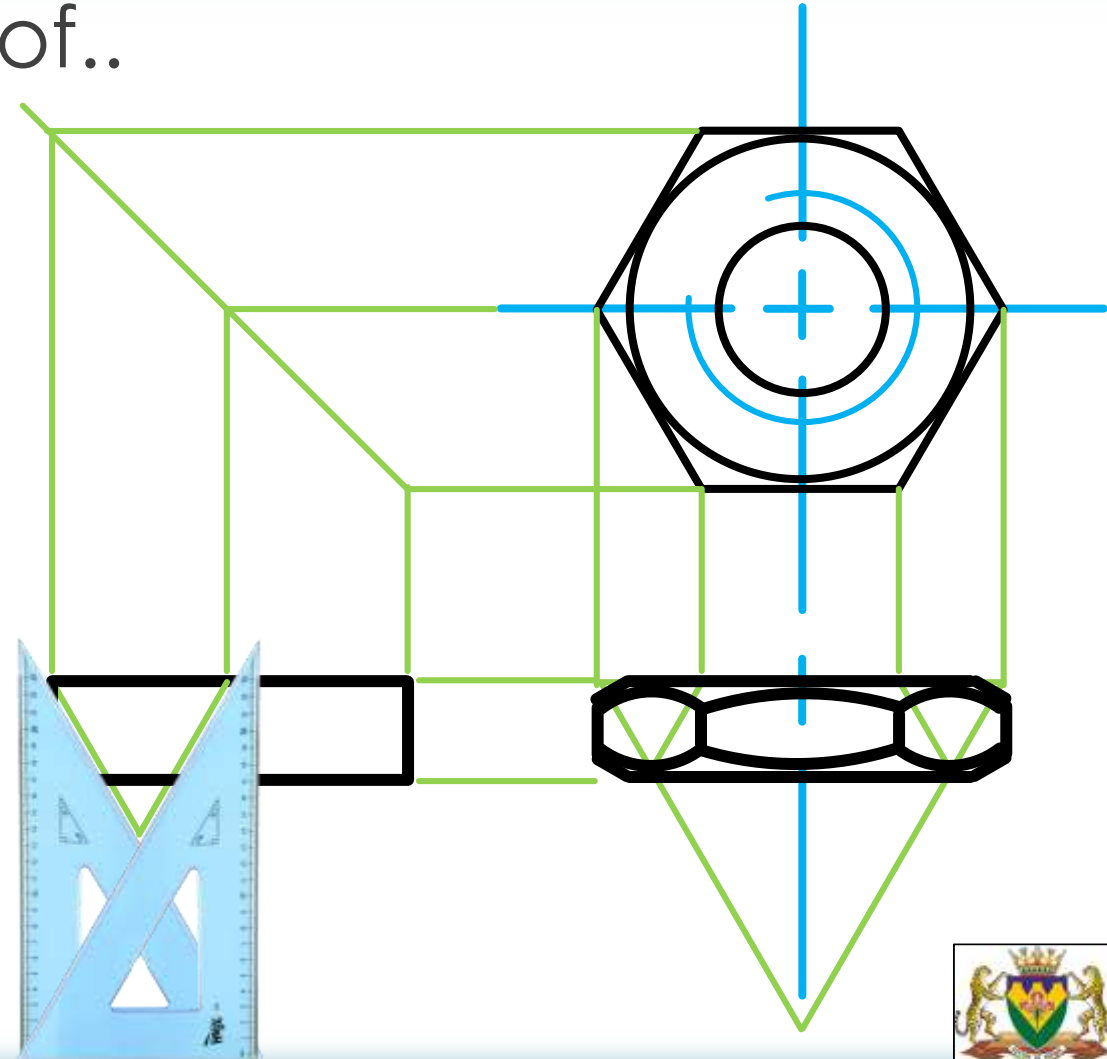
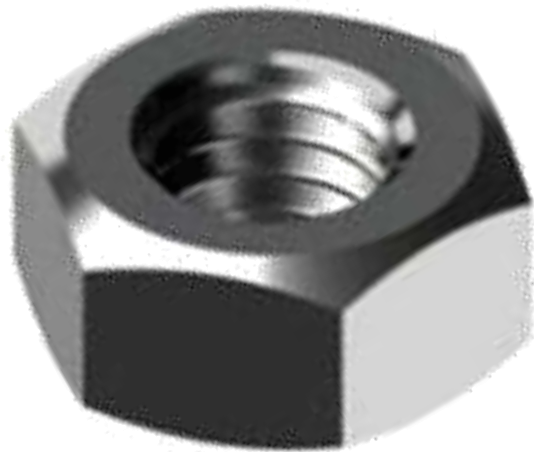

Construction of a NUT

- Construct the smaller upper arcs.

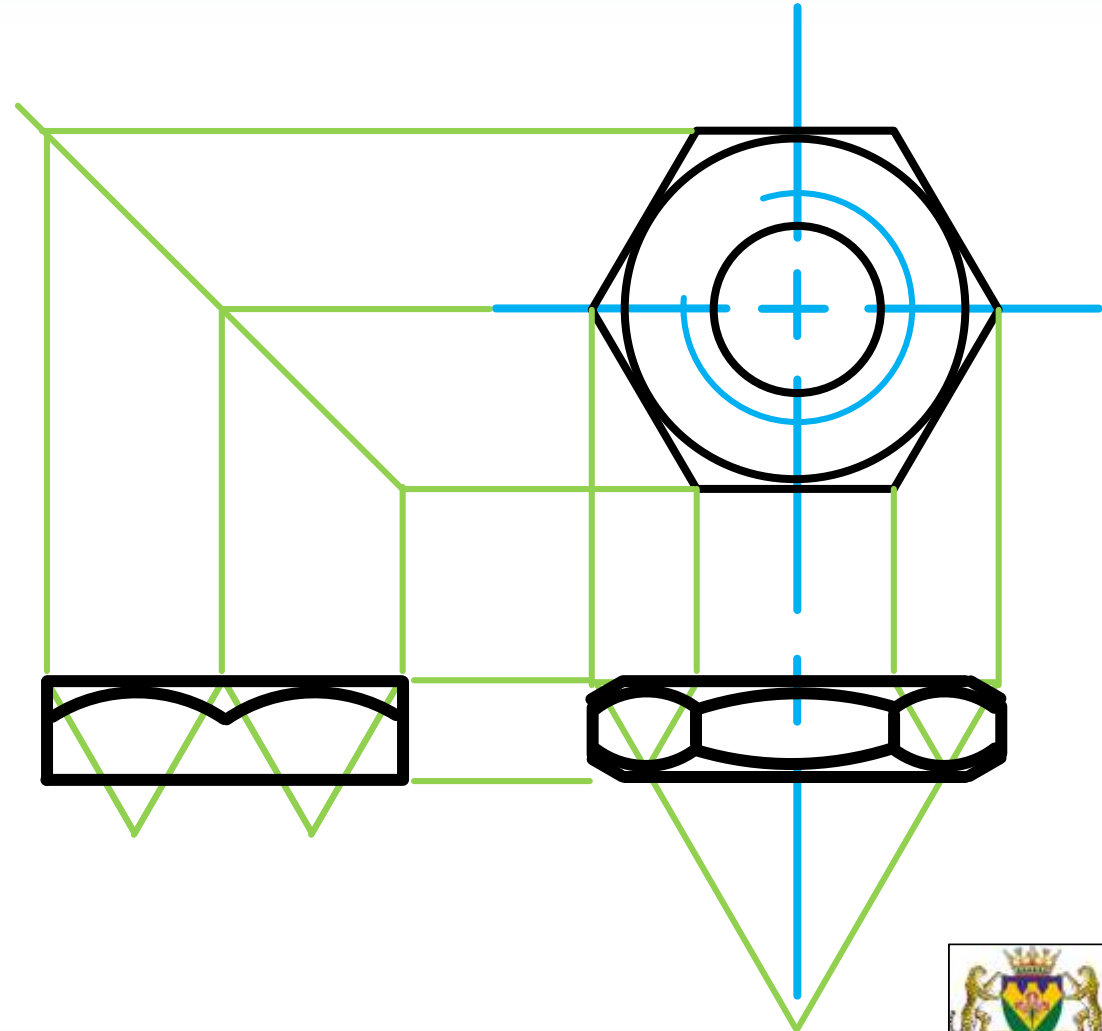
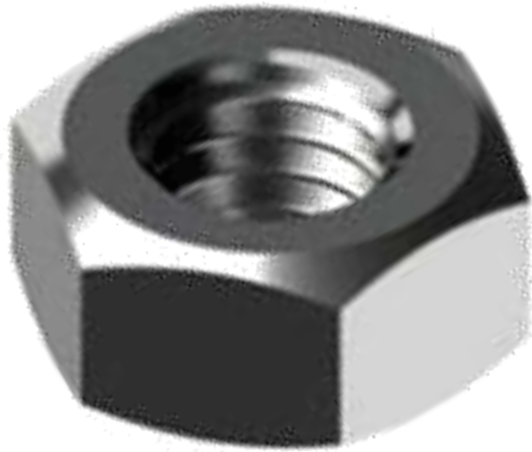

Construction of a NUT

- Construct the lower arcs.

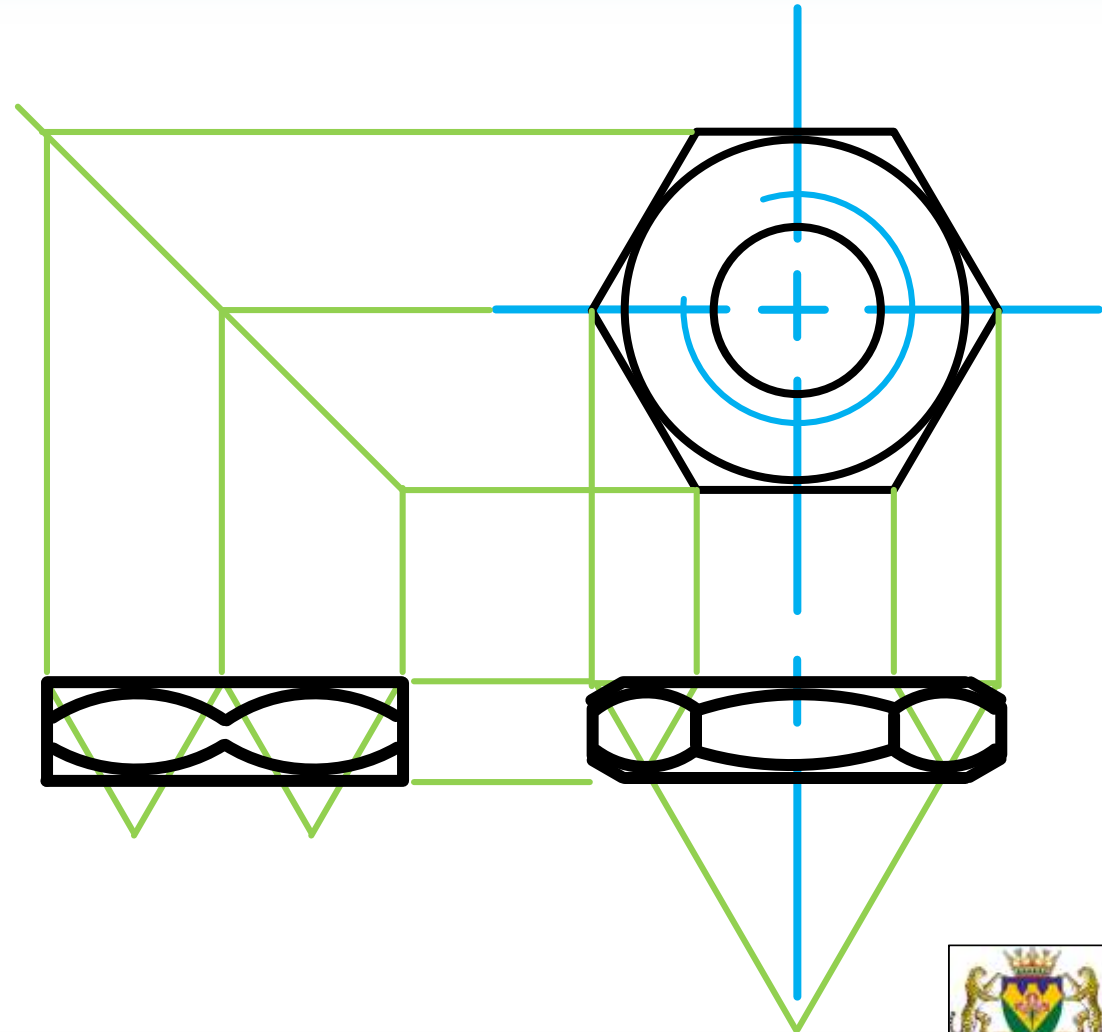
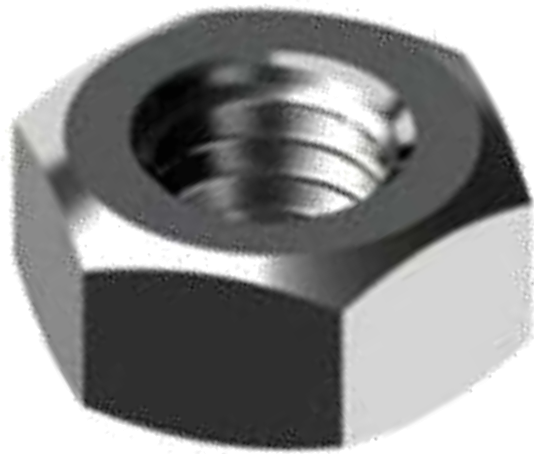

Construction of a NUT

- Compete the nut.

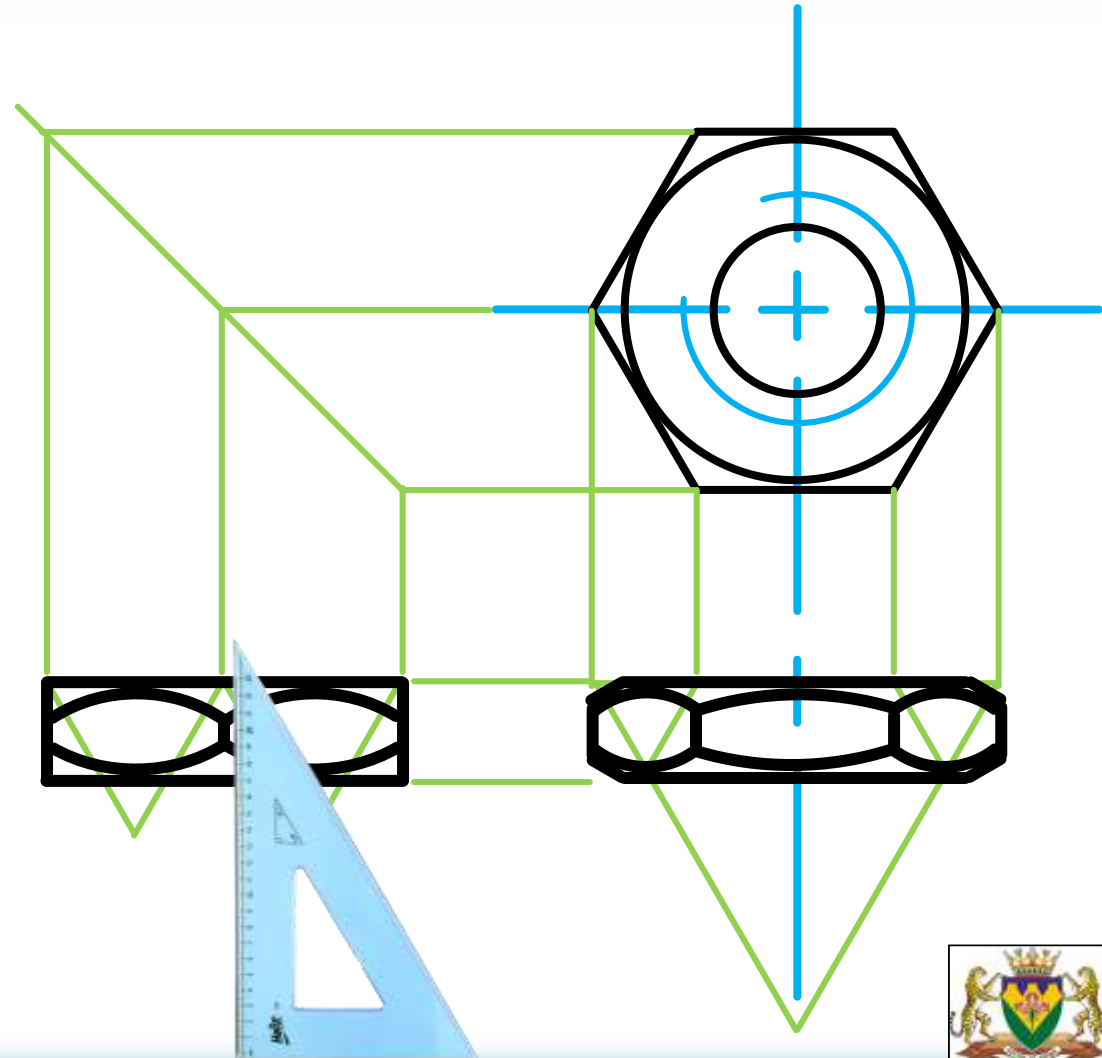
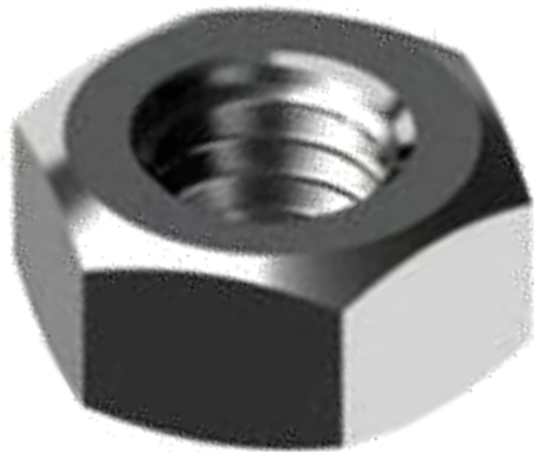

Mechanical Drawings (sectioning)

- ▶ Hatching of an internal hole.

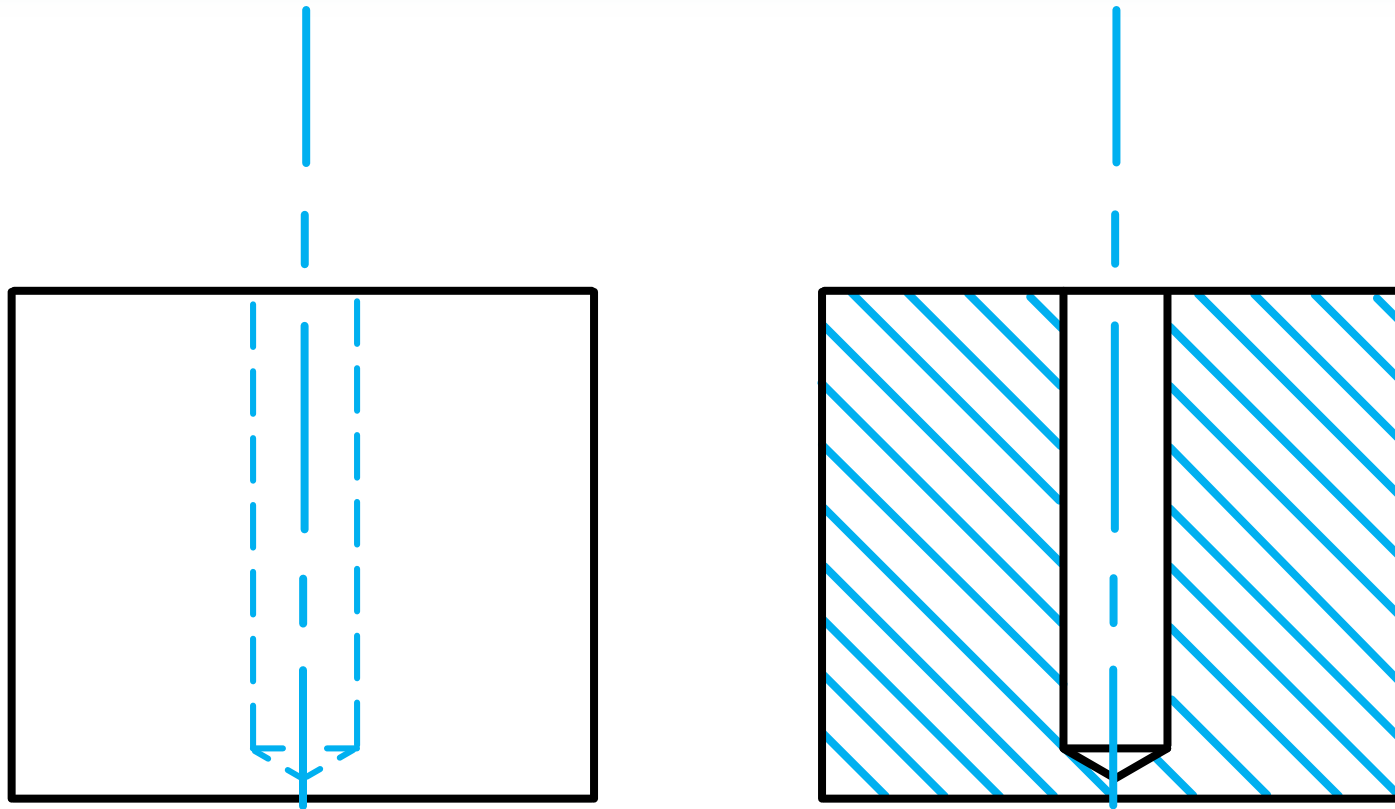

Mechanical Drawings (sectioning)

- ▶ Hatching of an internal hole with thread.

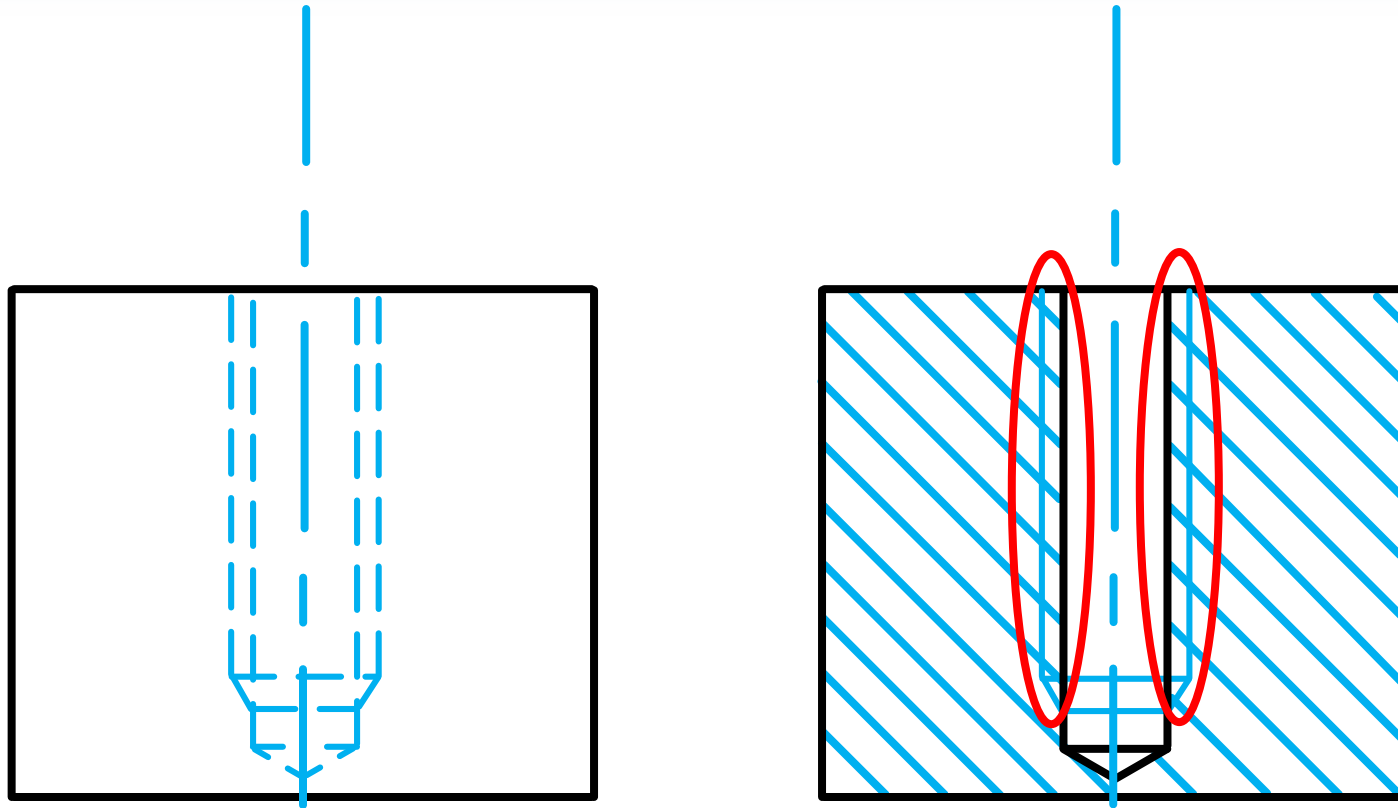

Mechanical Drawings (sectioning)

- **Studs** may **not** be sectioned when the cutting plane passes longitudinally through them.

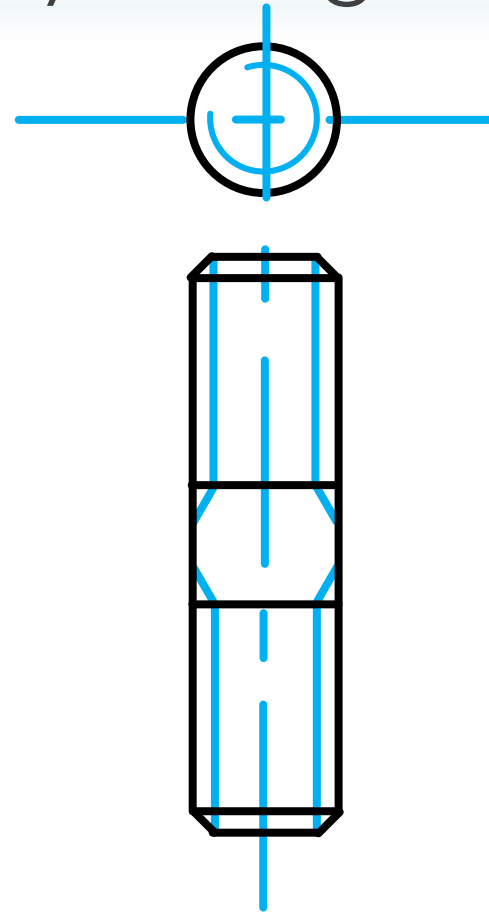

Mechanical Drawings (sectioning)

- **Washers** may **not** be sectioned when the cutting plane passes longitudinally through them.

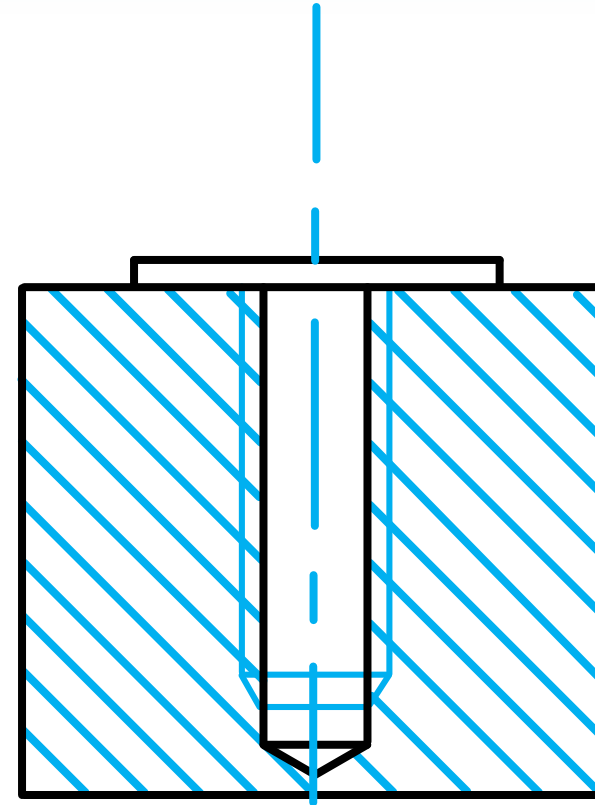

Mechanical Drawings (sectioning)

- ▶ Hatching an internal hole including a thread, washer, nut and a stud.

