



Surface developments

Prisms and pyramids

Grade 10, 11, 12

Developed by: PC Viljoen
Senior Educational Specialist for
Engineering Graphics and Design
Free State Province

Application on polygons

- Projecting right regular pyramids, prisms, cones and cylinders from polygons.

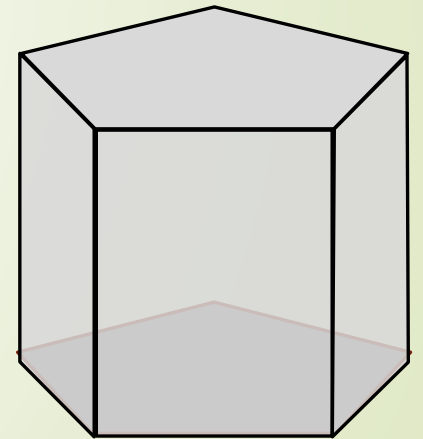
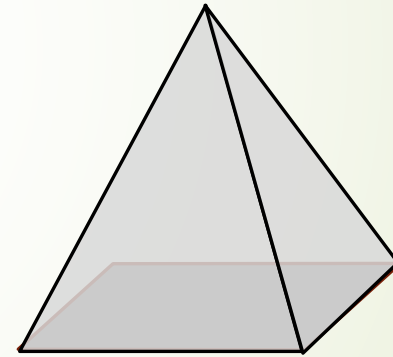
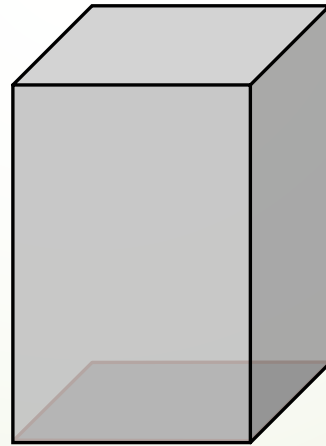
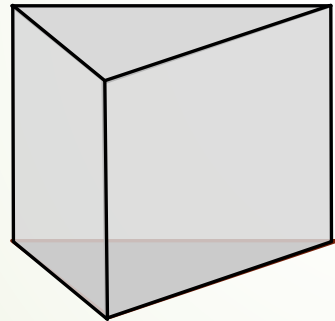
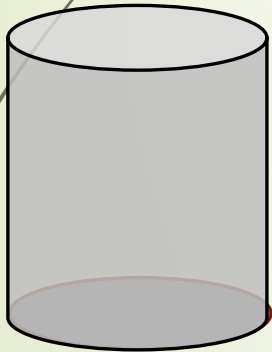

Application on polygons

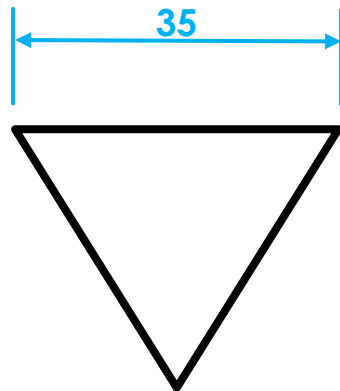
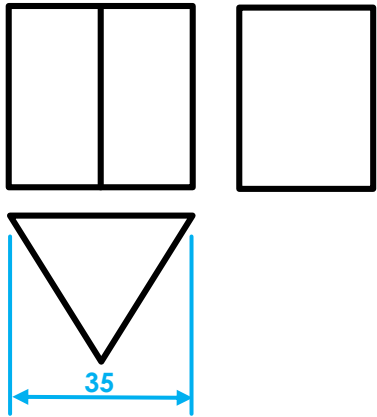

Given:

A regular triangular prism 78 mm high with base side lengths of 35mm.

Question:

In F.A.O.P. draw...

1. A front view
2. A sectioned left view
3. **A top view**
4. Develop the surface of the solid

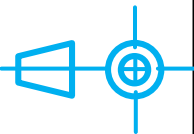

FRONT VIEW

Principles of surface developments

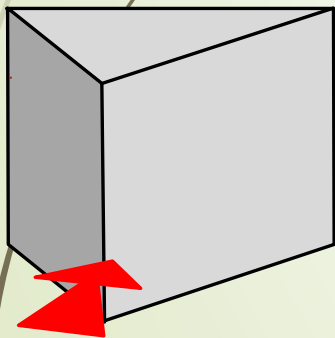
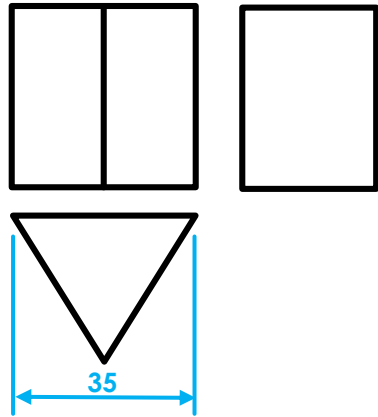

FRONT VIEW

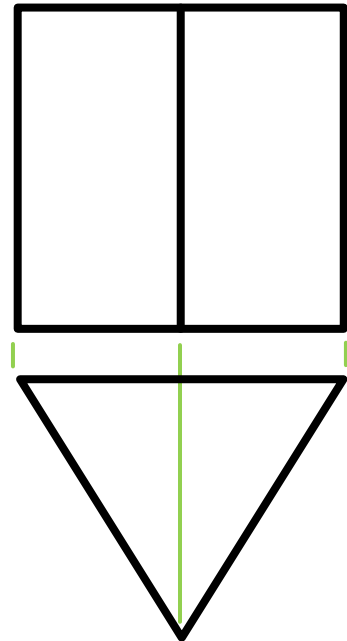

Given:

A regular triangular prism 78 mm high with base side lengths of 35mm.

Question:

In F.A.O.P. draw...

1. **A front view**
2. A sectioned left view
3. A top view
4. Develop the surface of the solid

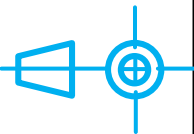

Principles of surface developments

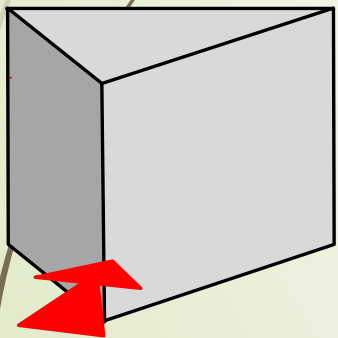
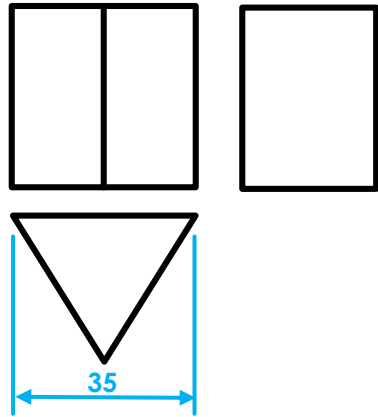

FRONT VIEW

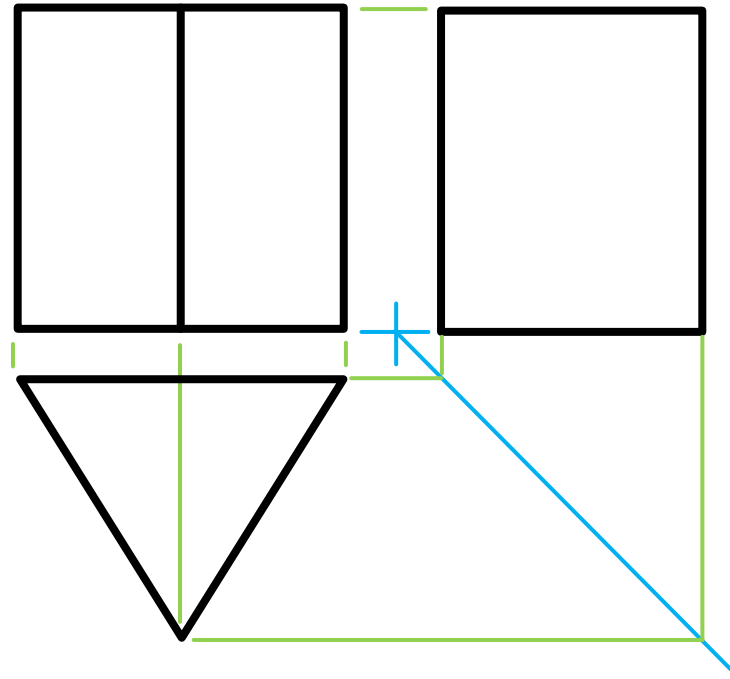

Given:

A regular triangular prism 78 mm high with base side lengths of 35mm.

Question:

In F.A.O.P. draw...

1. A front view
2. **A left view**
3. A top view
4. Develop the surface of the solid

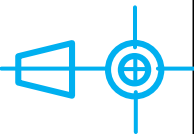

Principles of surface developments

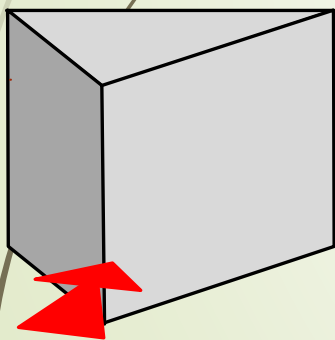
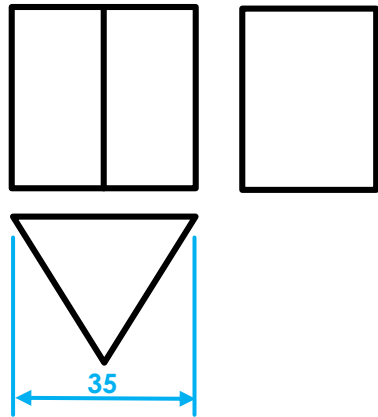

FRONT VIEW

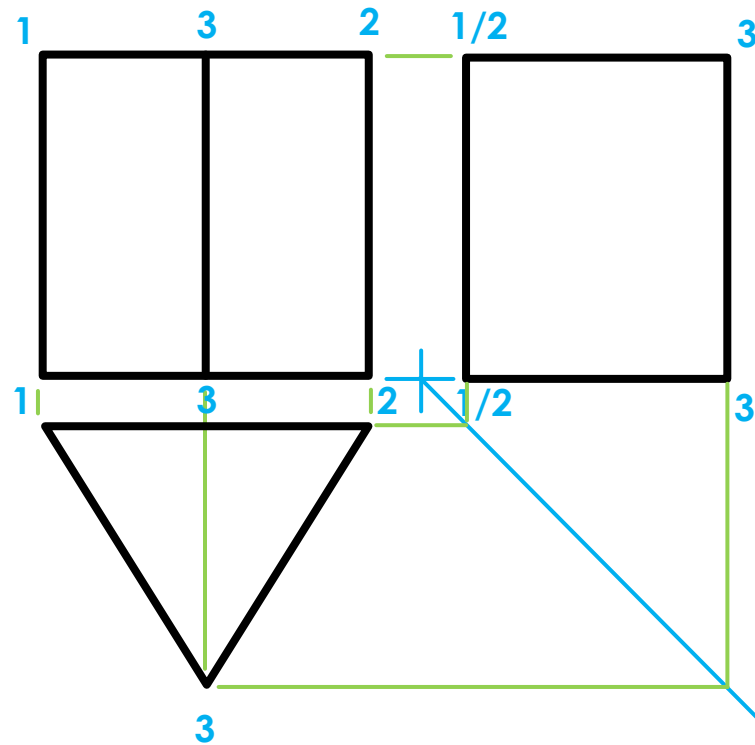

Given:

A regular triangular prism 78 mm high with base side lengths of 35mm.

Question:

In F.A.O.P. draw...

1. A front view
2. A sectioned left view
3. A top view

4. Develop the surface of the solid

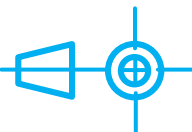

Principles of surface developments

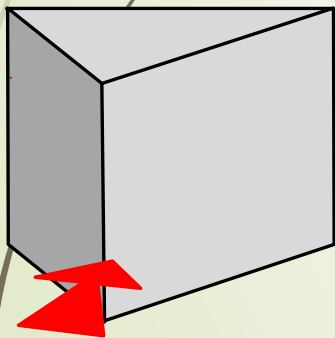
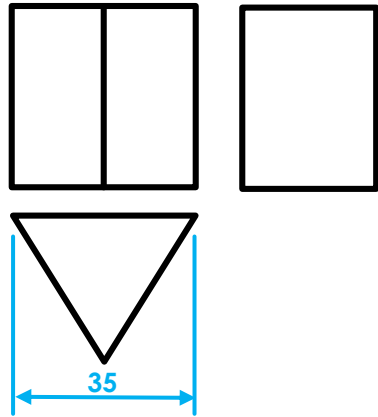

FRONT VIEW

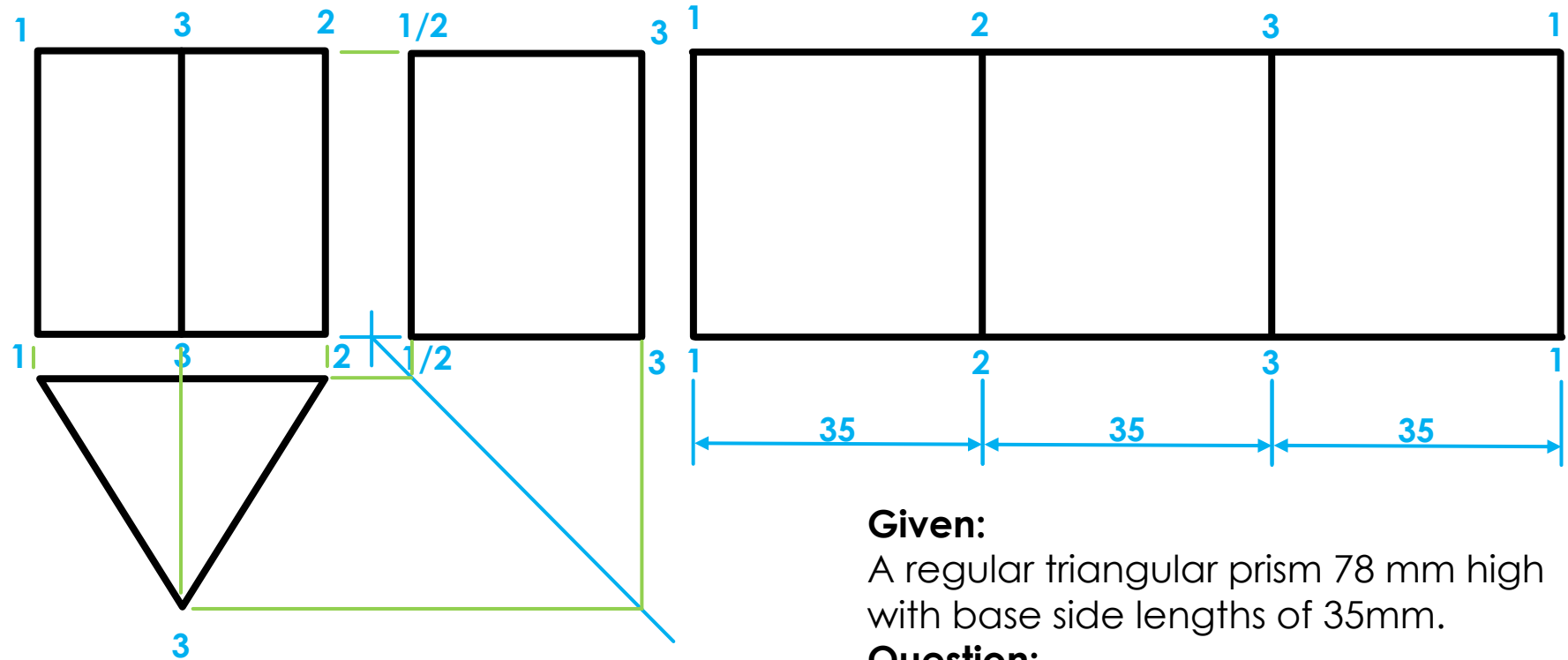

Given:

A regular triangular prism 78 mm high with base side lengths of 35mm.

Question:

In F.A.O.P. draw...

1. A front view
2. A sectioned left view
3. A top view

4. Develop the surface of the solid

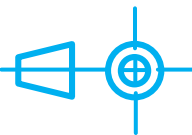

Principles of surface developments

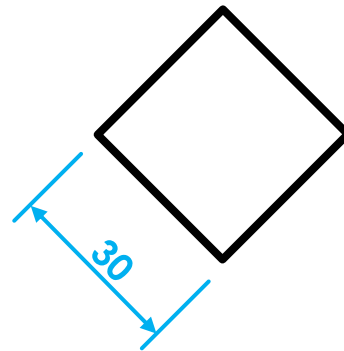
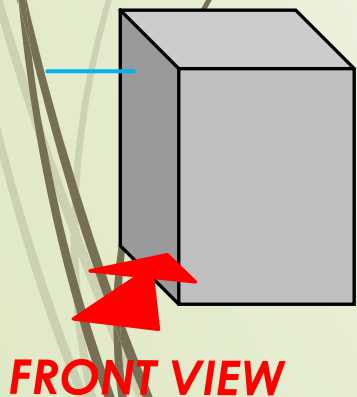
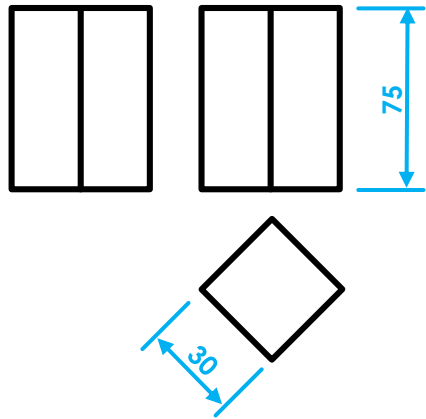

Given:

A regular square prism 75 mm high and base side lengths of 30mm.

Question:

In F.A.O.P. draw...

1. A front view
2. A right view
- 3. A top view**
4. Develop the surface of the solid

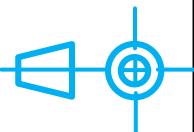

Principles of surface developments

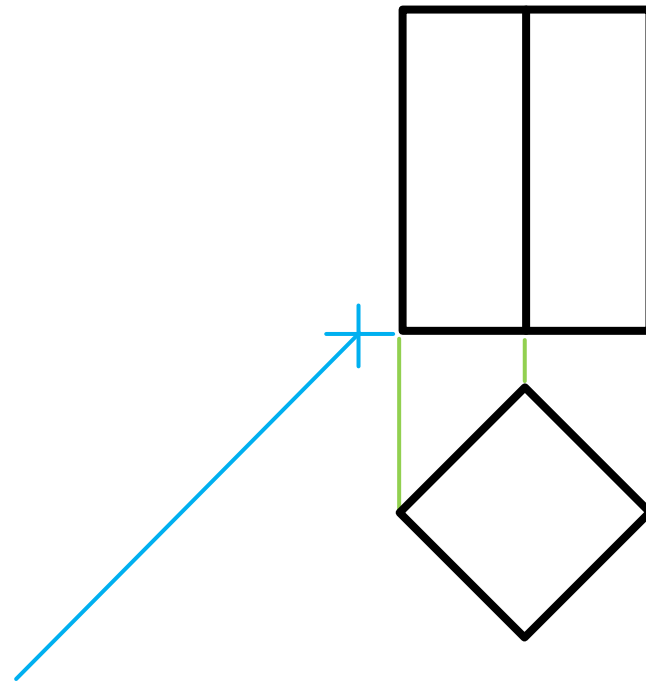
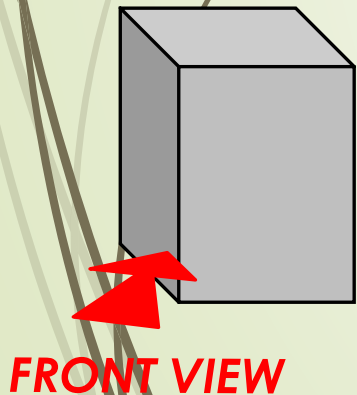
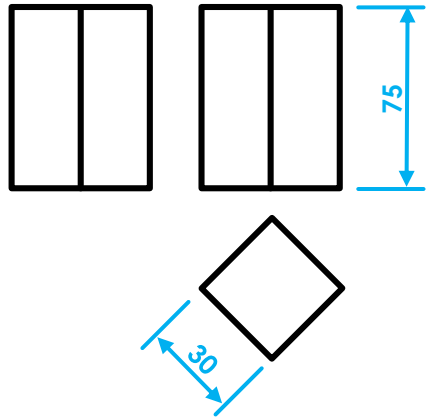

Given:

A regular square prism 75 mm high and base side lengths of 30mm.

Question:

In F.A.O.P. draw...

1. A front view
2. A right view
3. A top view
4. Develop the surface of the solid

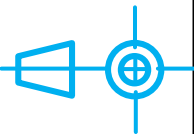

Principles of surface developments

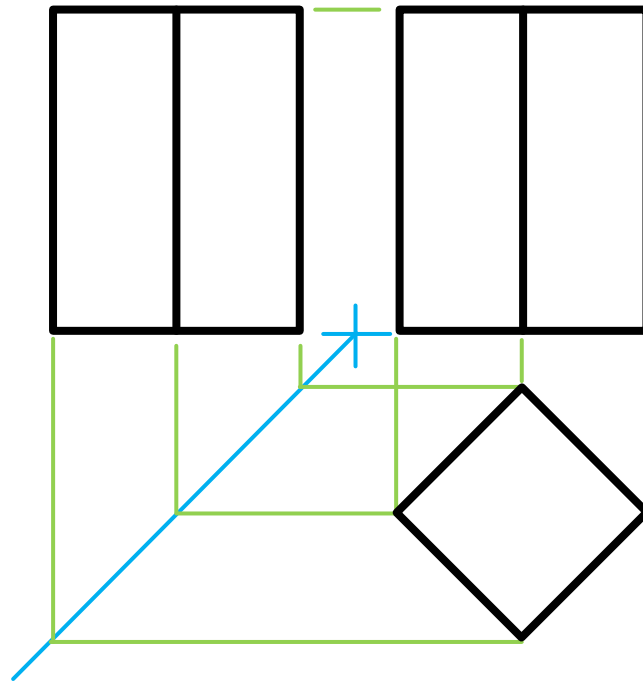
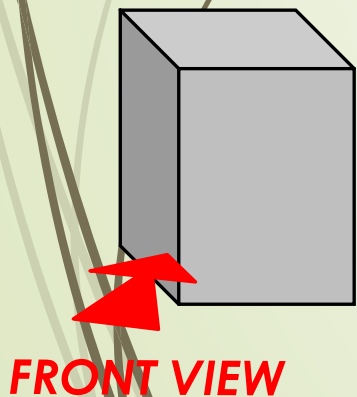
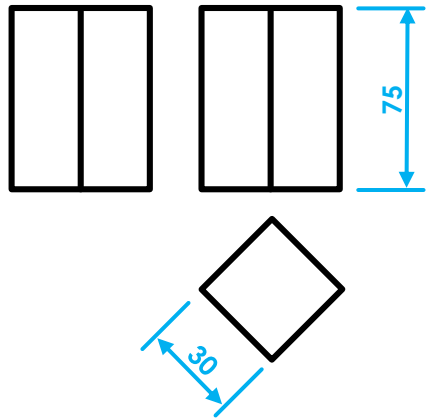

Given:

A regular square prism 75 mm high and base side lengths of 30mm.

Question:

In F.A.O.P. draw...

1. A front view
2. **A right view**
3. A top view
4. Develop the surface of the solid

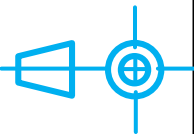

Principles of surface developments

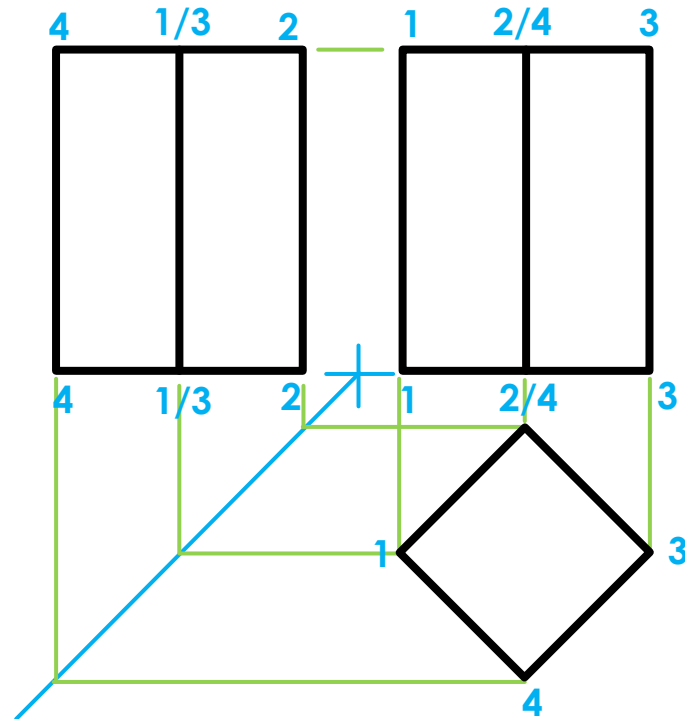
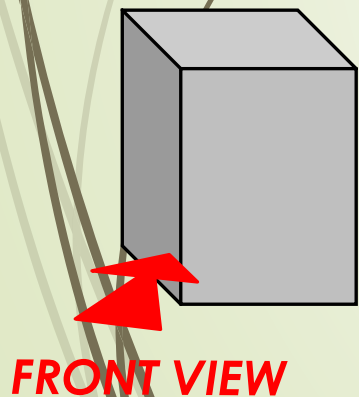
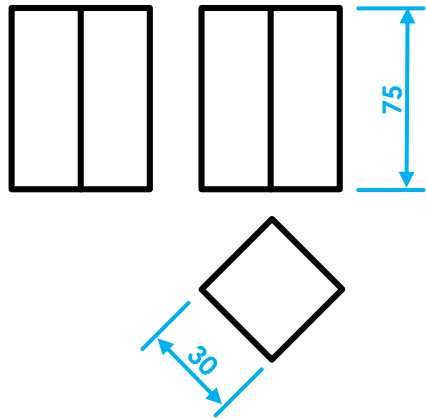

Given:

A regular square prism 75 mm high and base side lengths of 30mm.

Question:

In F.A.O.P. draw...

1. A sectioned front view
2. A right view
3. A top view

4. Develop the surface of the solid

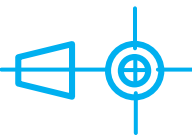

Principles of surface developments

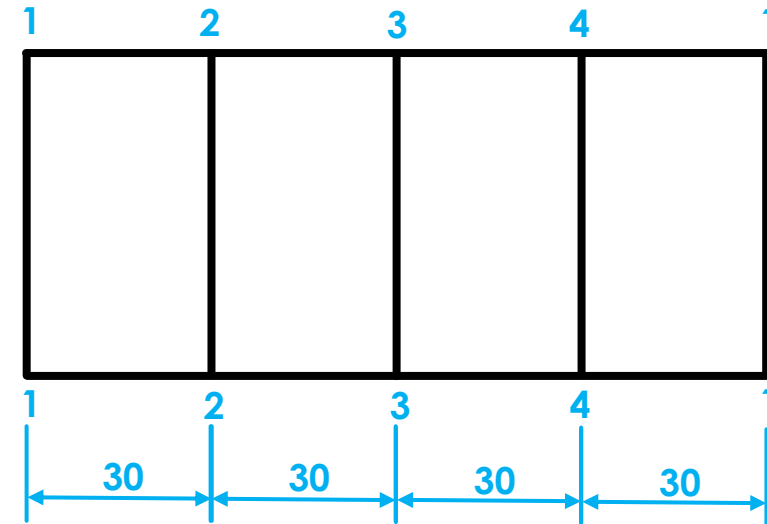
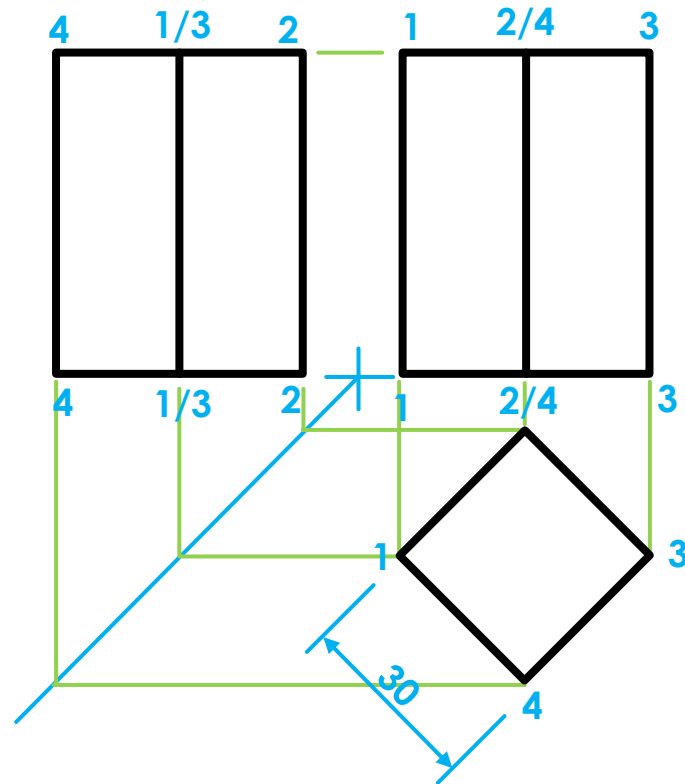
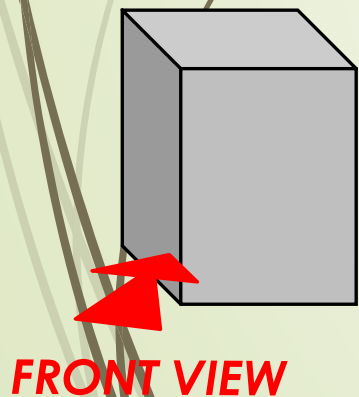
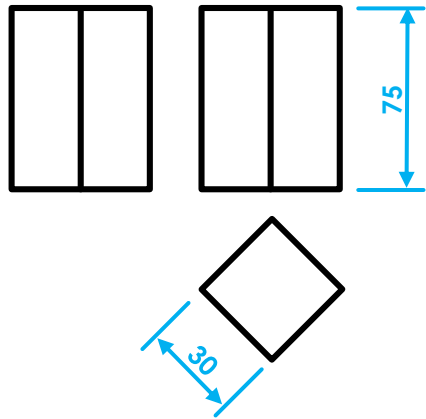

Given:

A regular square prism 75 mm high and base side lengths of 30mm.

Question:

In F.A.O.P. draw...

1. A sectioned front view
2. A right view
3. A top view

4. Develop the surface of the solid

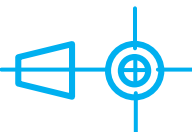

Principles of surface developments

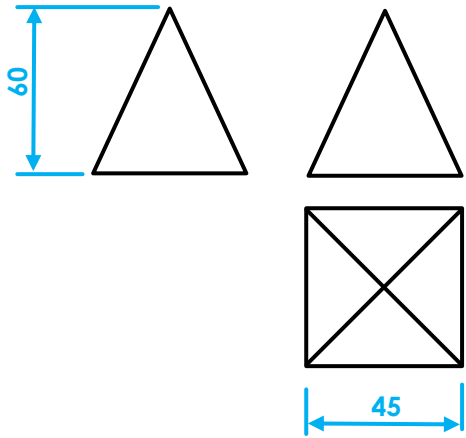

Given:

A regular square pyramid 60 mm high with base side lengths of 45mm.

Question:

In F.A.O.P. draw...

1. A front view
2. A right view
3. A **top view**
4. Develop the surface of the solid

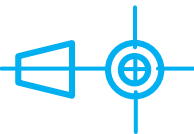
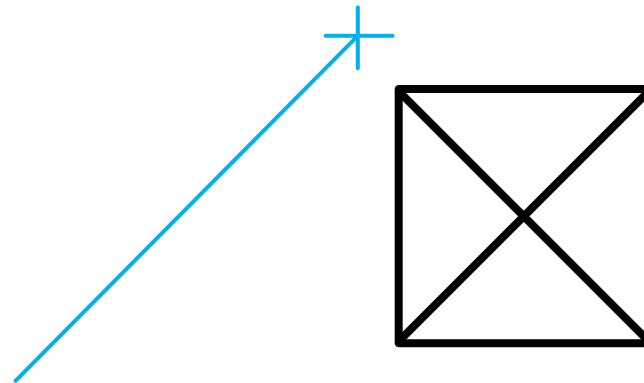
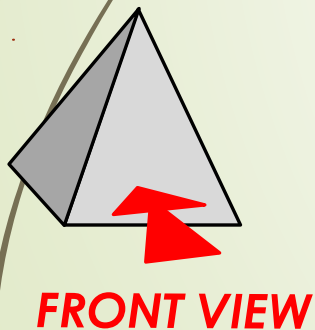

Principles of surface developments

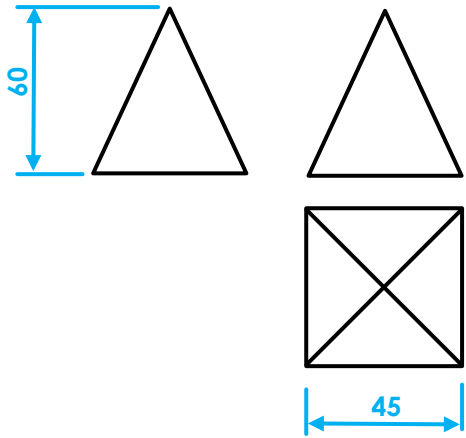

Given:

A regular square pyramid 60 mm high with base side lengths of 45mm.

Question:

In F.A.O.P. draw...

1. A front view
2. A right view
3. A top view
4. Develop the surface of the solid

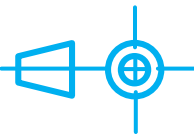
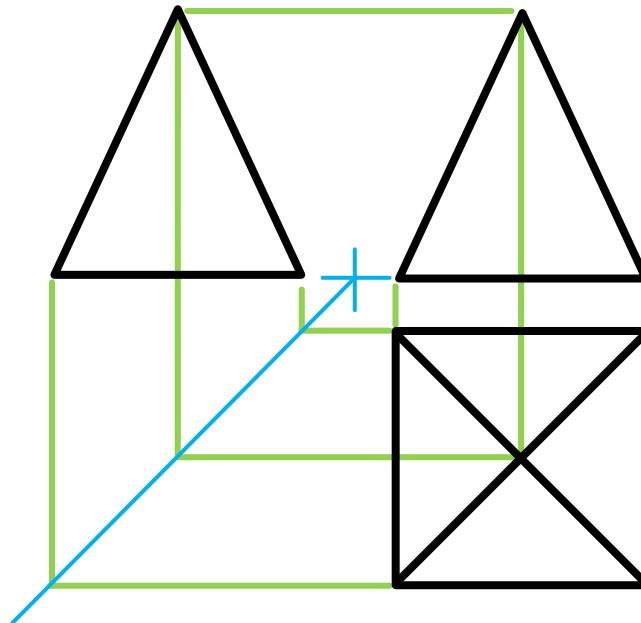

Principles of surface developments

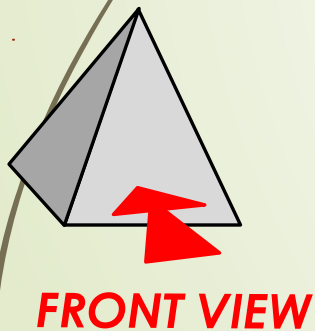
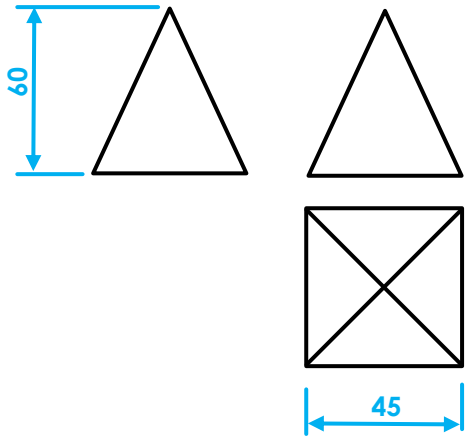

Given:

A regular square pyramid 60 mm high with base side lengths of 45mm.

Question:

In F.A.O.P. draw...

1. A front view
2. A right view
3. A top view
4. **Develop the surface of the solid**

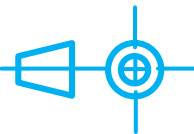
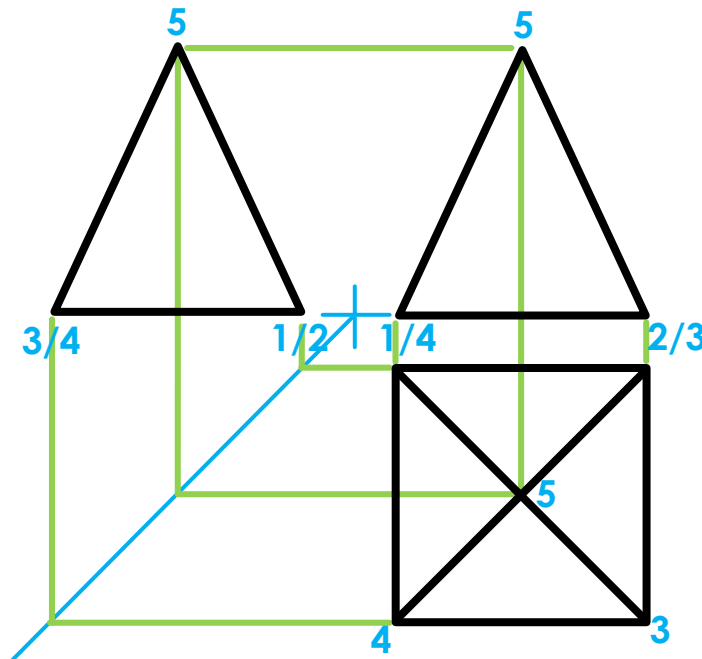

Principles of surface developments

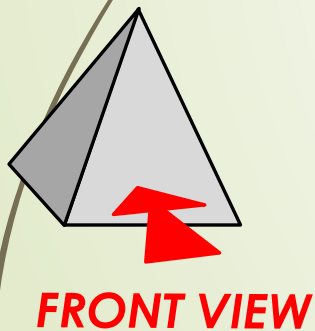
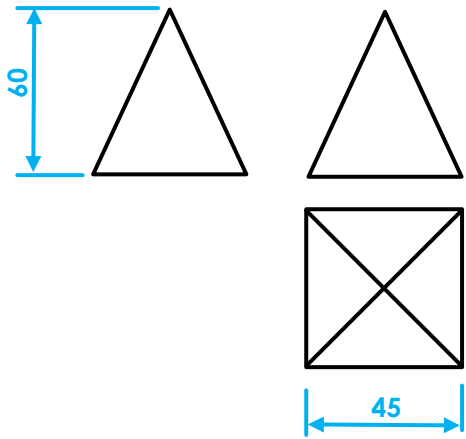

Given:

A regular square pyramid 60 mm high with base side lengths of 45mm.

Question:

In F.A.O.P. draw...

1. A front view
2. A right view
3. A top view
- 4. Develop the surface of the solid**

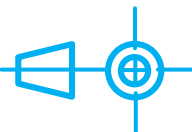
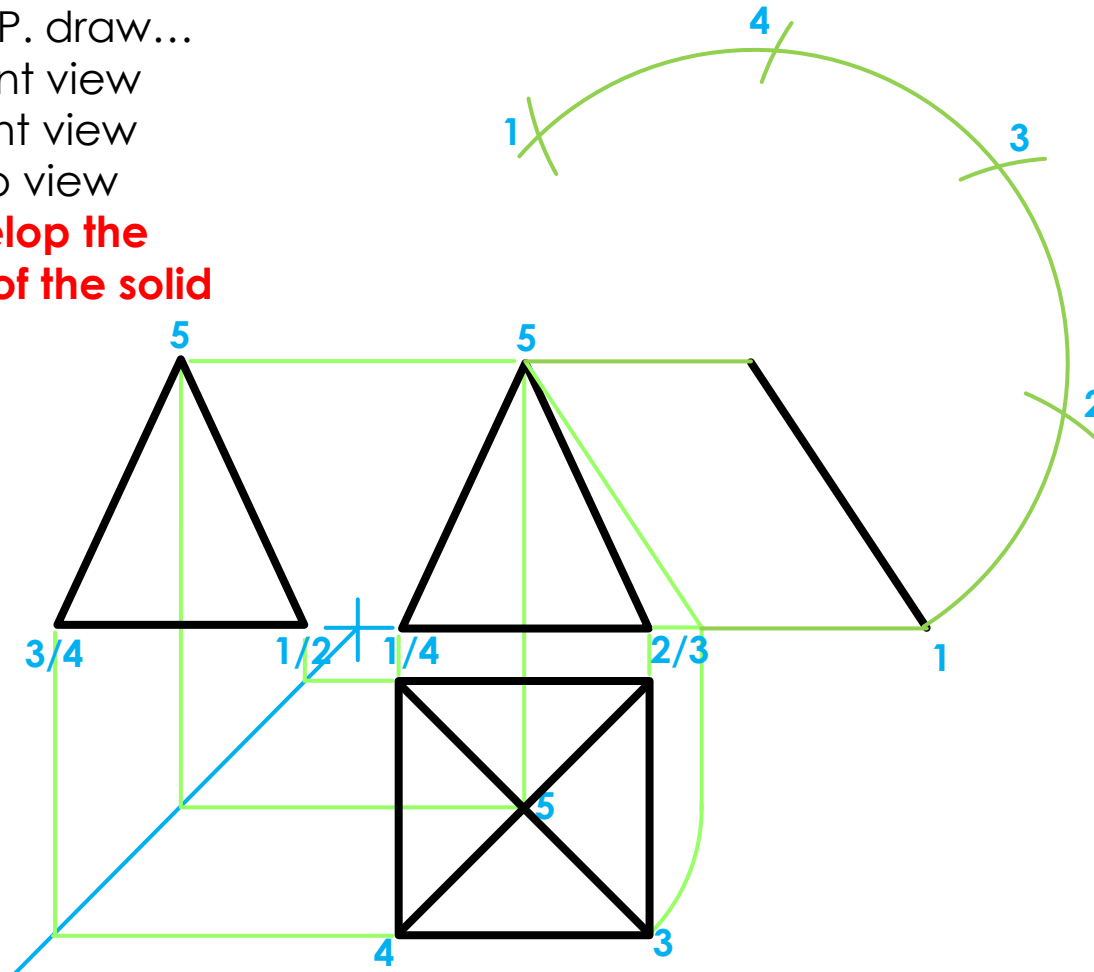

Principles of surface developments

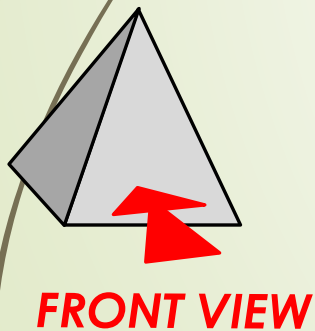
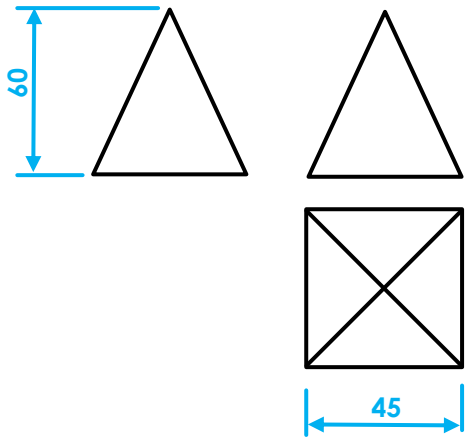

Given:

A regular square pyramid 60 mm high with base side lengths of 45mm.

Question:

In F.A.O.P. draw...

1. A front view
2. A right view
3. A top view
- 4. Develop the surface of the solid**

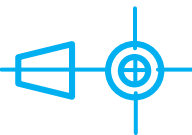
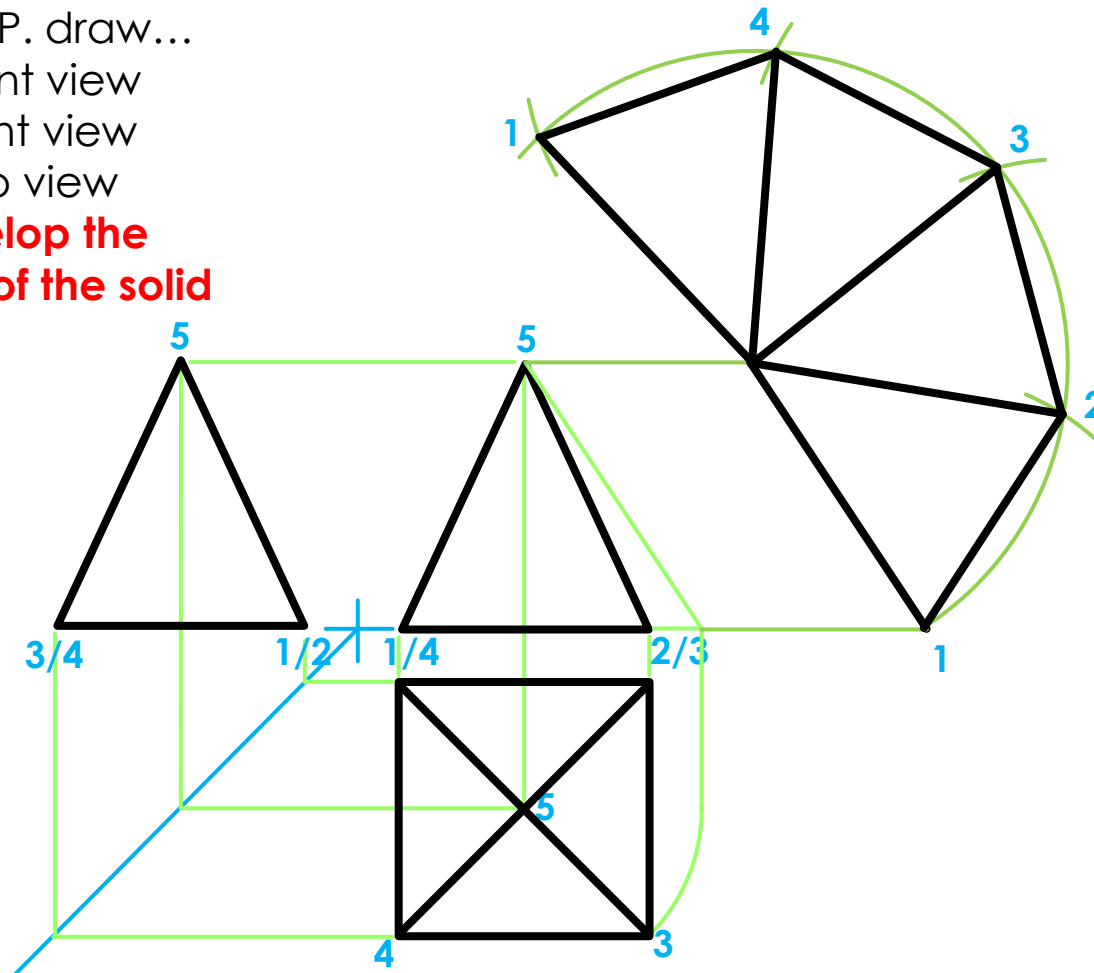

Principles of surface developments

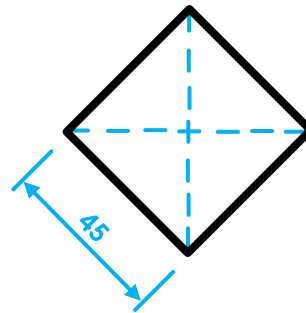
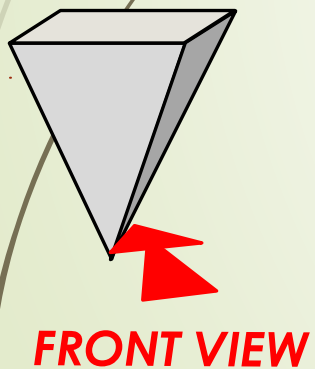
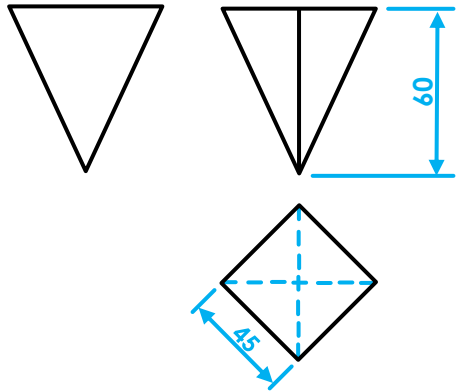

Given:

A regular square pyramid 60 mm high.

Question:

In F.A.O.P. draw...

1. A front view
2. A right view
3. **A top view**
4. Develop the surface of the solid

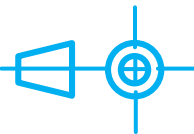

Principles of surface developments

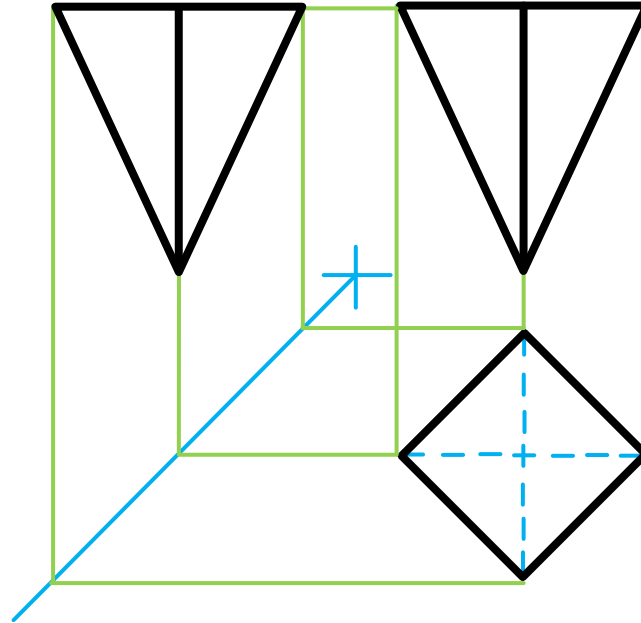
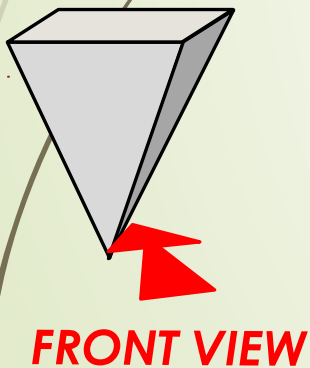
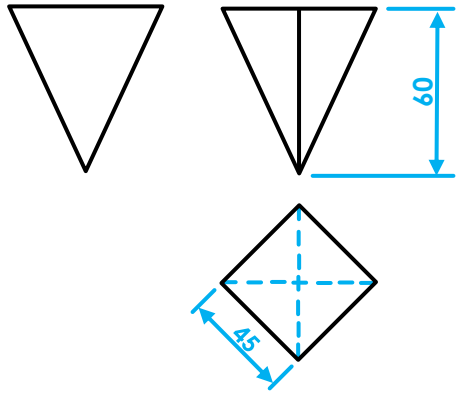

Given:

A regular square pyramid 60 mm high.

Question:

In F.A.O.P. draw...

1. A front view
2. A right view
3. A top view
4. Develop the surface of the solid

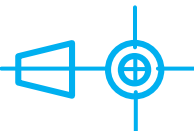

Principles of surface developments

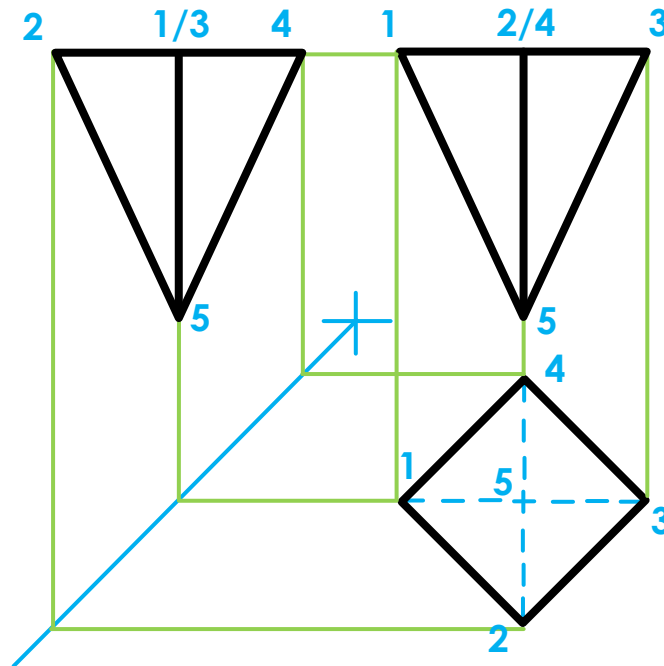
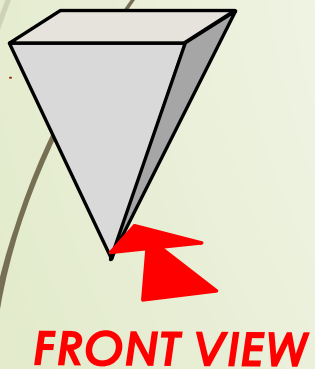
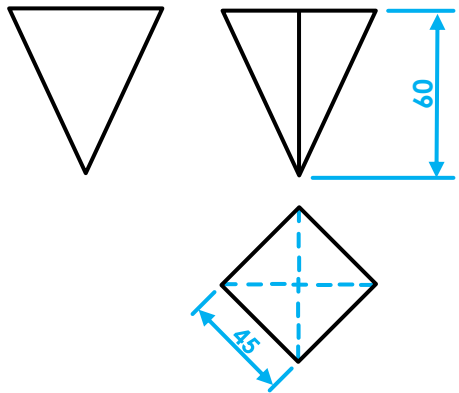

Given:

A regular square pyramid 60 mm high.

Question:

In F.A.O.P. draw...

1. A front view
2. A right view
3. A top view
4. **Develop the surface of the solid**

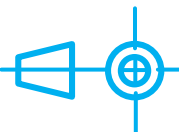

Principles of surface developments

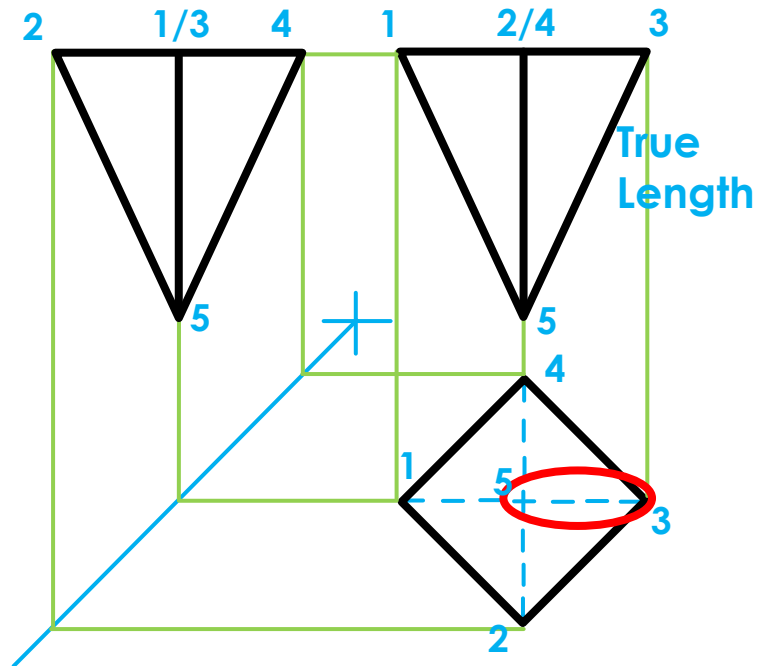
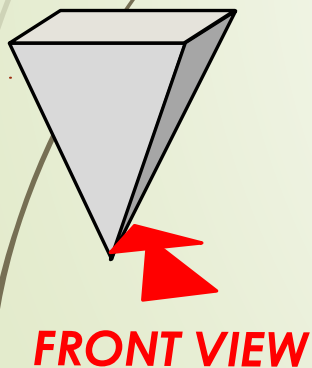
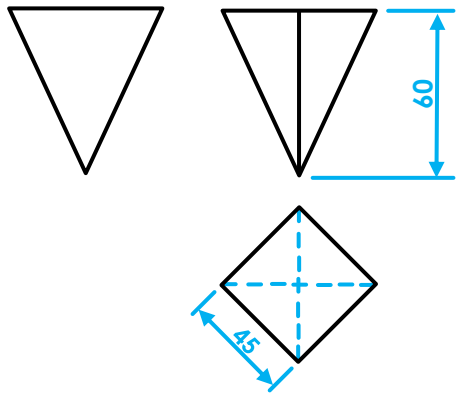

Given:

A regular square pyramid 60 mm high.

Question:

In F.A.O.P. draw...

1. A front view
2. A right view
3. A top view
- 4. Develop the surface of the solid**

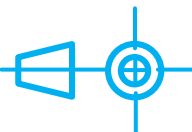

Principles of surface developments

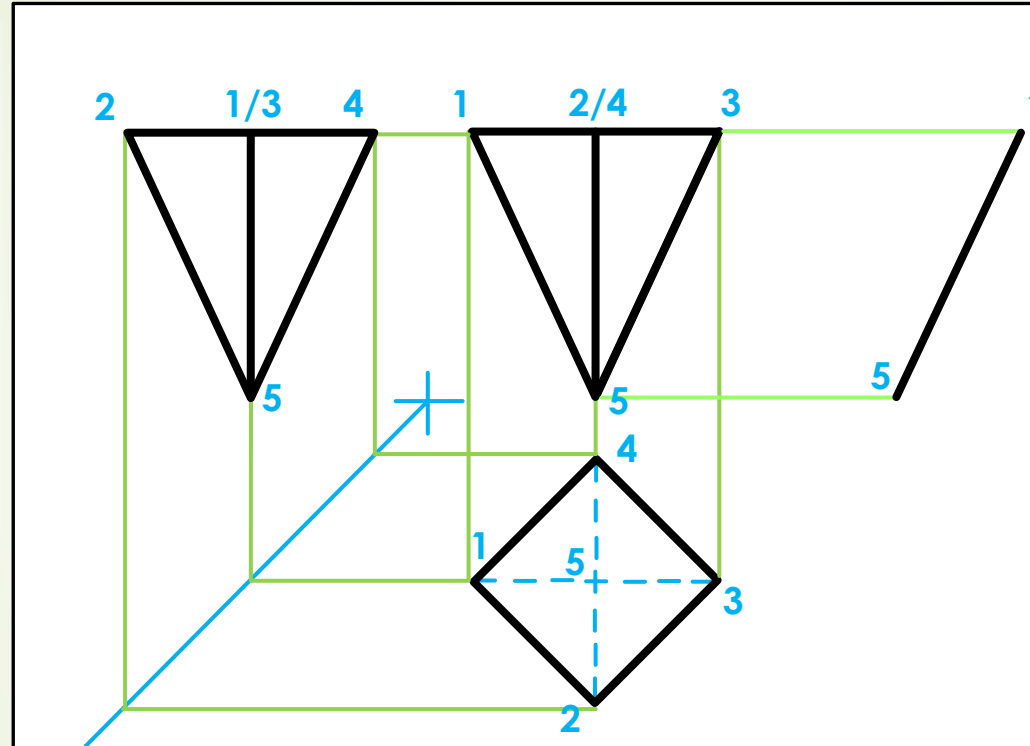
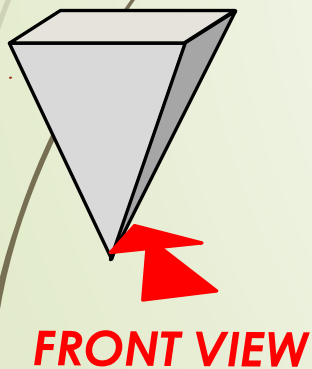
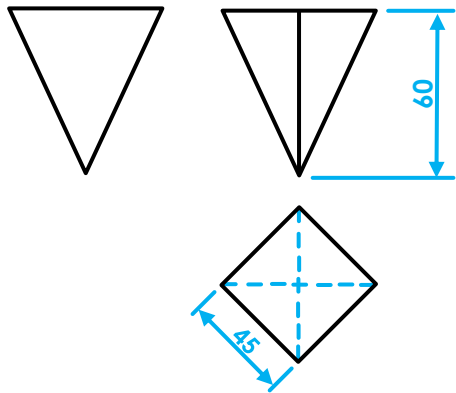

Given:

A regular square pyramid 60 mm high.

Question:

In F.A.O.P. draw...

1. A front view
2. A right view
3. A top view
- 4. Develop the surface of the solid**

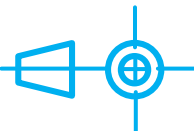

Principles of surface developments

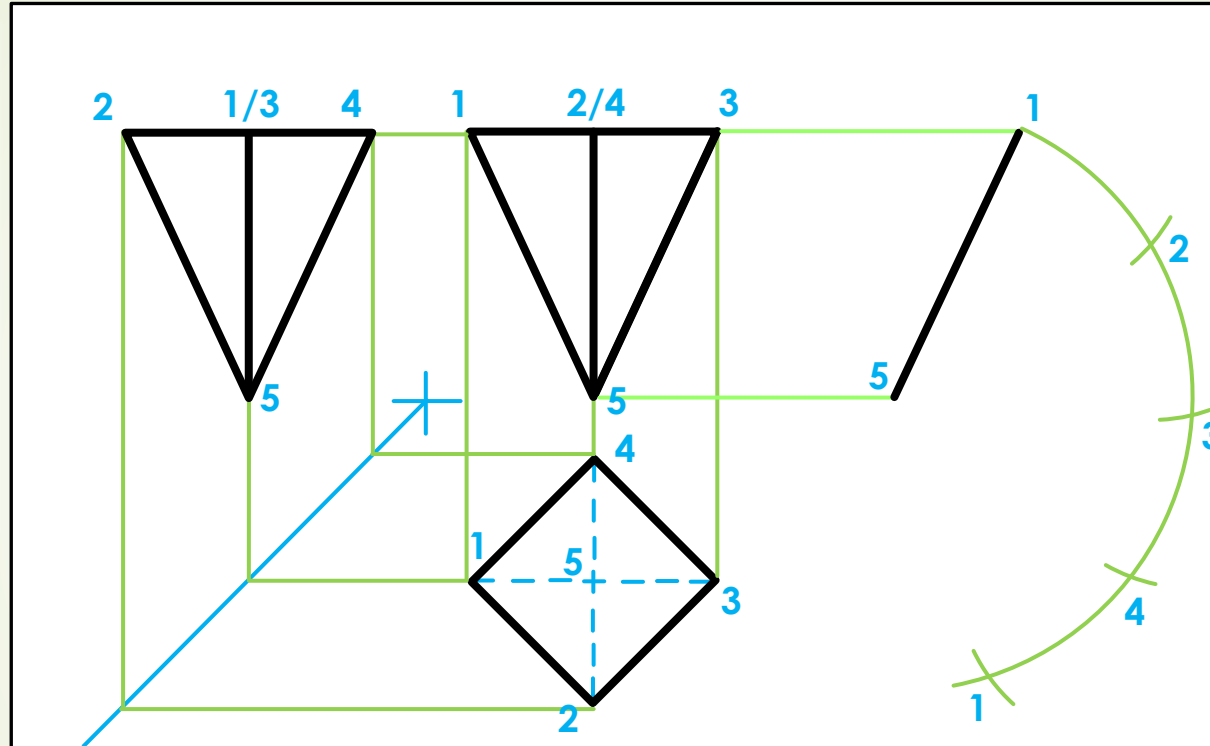
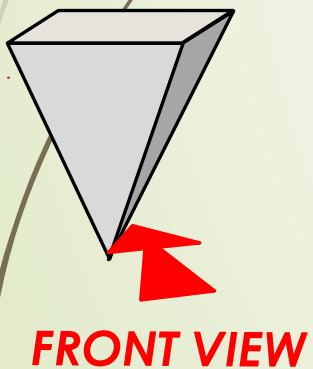
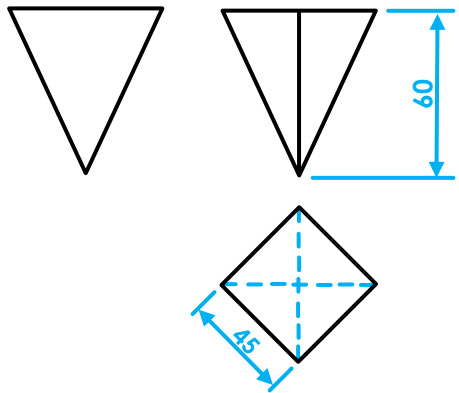

Given:

A regular square pyramid 60 mm high.

Question:

In F.A.O.P. draw...

1. A front view
2. A right view
3. A top view

4. Develop the surface of the solid

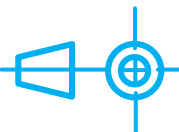

Principles of surface developments

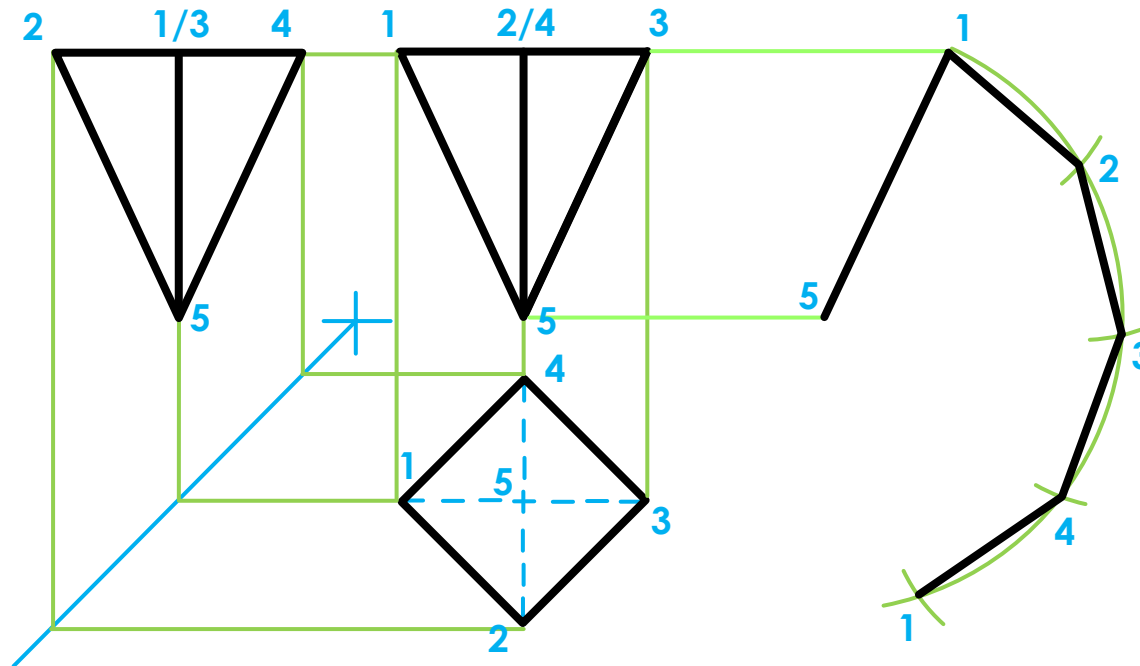
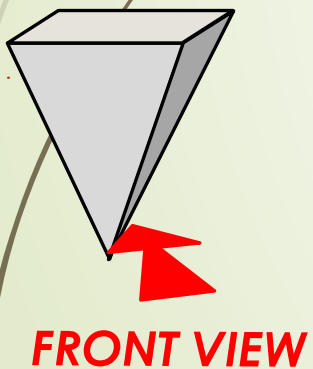
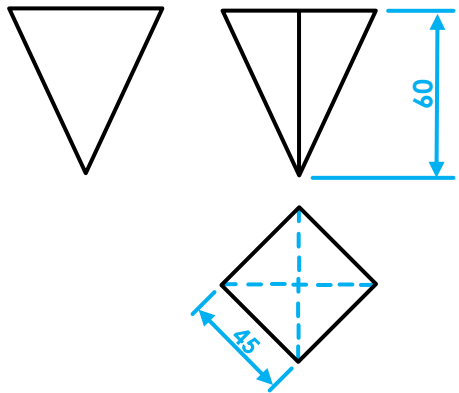

Given:

A regular square pyramid 60 mm high.

Question:

In F.A.O.P. draw...

1. A front view
2. A right view
3. A top view
- 4. Develop the surface of the solid**

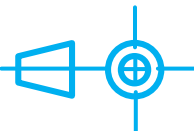

Principles of surface developments

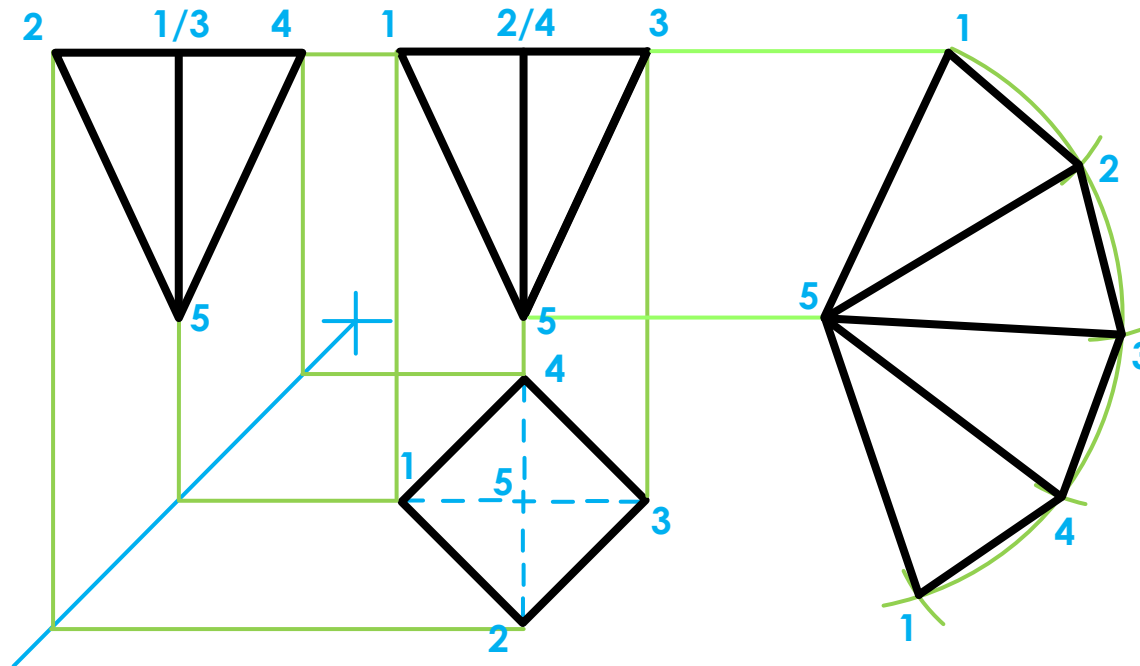
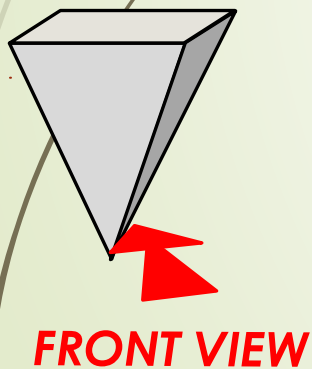
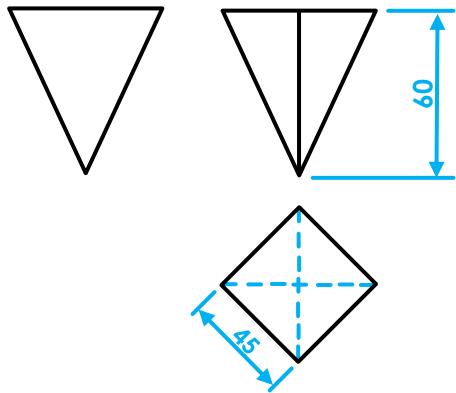

Given:

A regular square pyramid 60 mm high.

Question:

In F.A.O.P. draw...

1. A front view
2. A right view
3. A top view
- 4. Develop the surface of the solid**

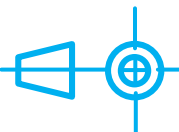

Principles of surface developments

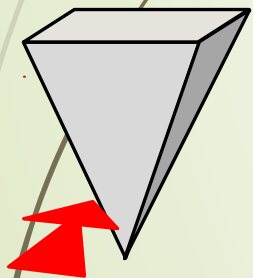
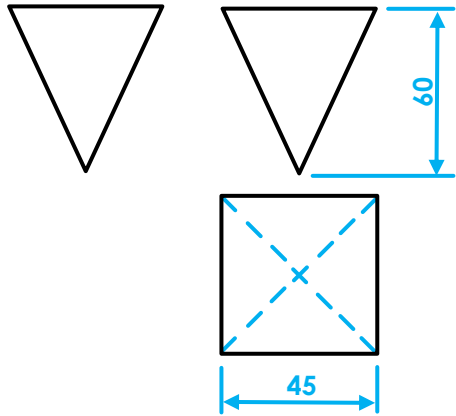

FRONT VIEW

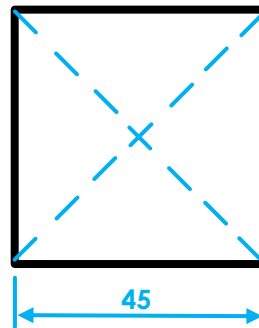

Given:

A regular square pyramid 60 mm high.

Question:

In F.A.O.P. draw...

1. A front view
2. A right view
- 3. A top view**
4. Develop the surface of the solid

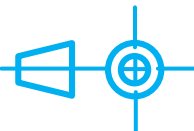

Principles of surface developments

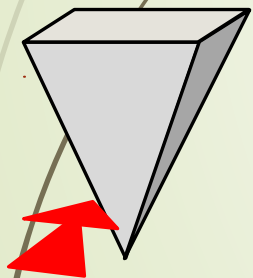
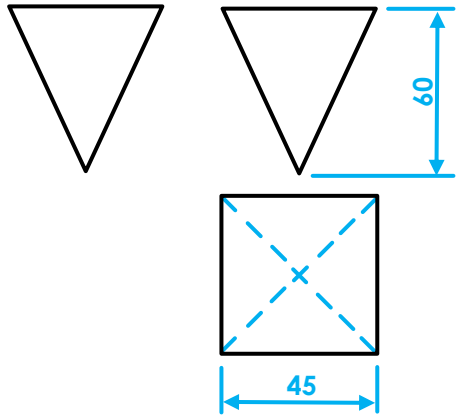

FRONT VIEW

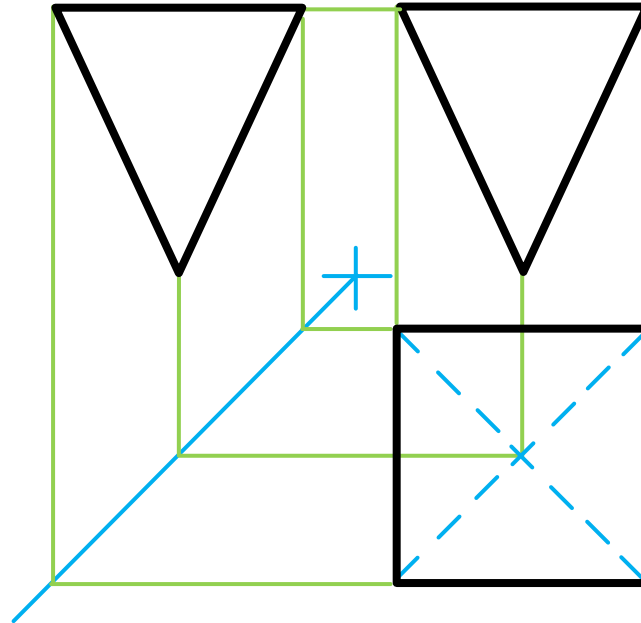

Given:

A regular square pyramid 60 mm high.

Question:

In F.A.O.P. draw...

1. A front view
2. A right view
3. A top view
4. Develop the surface of the solid

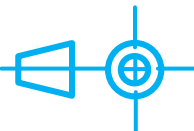

Principles of surface developments

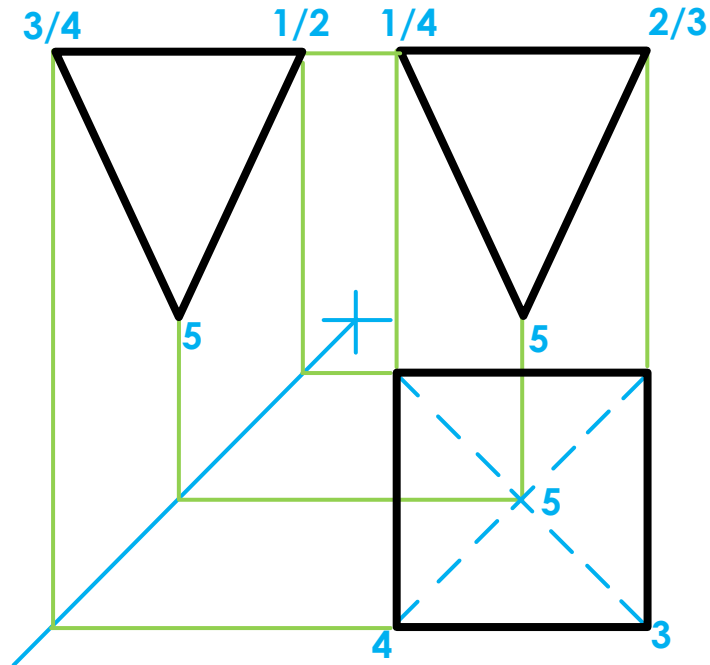
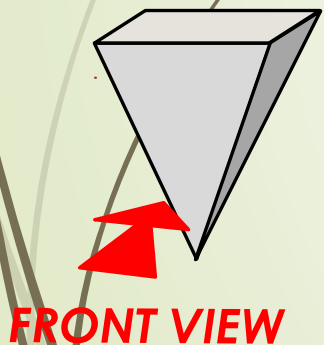
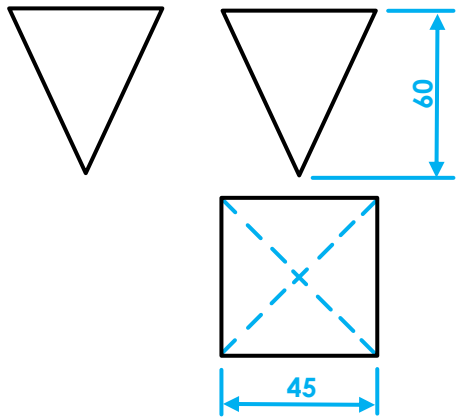

Given:

A regular square pyramid 60 mm high.

Question:

In F.A.O.P. draw...

1. A front view
2. A right view
3. A top view
4. **Develop the surface of the solid**

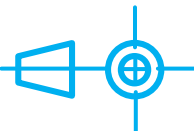

Principles of surface developments

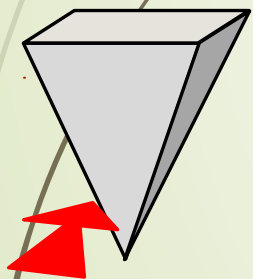
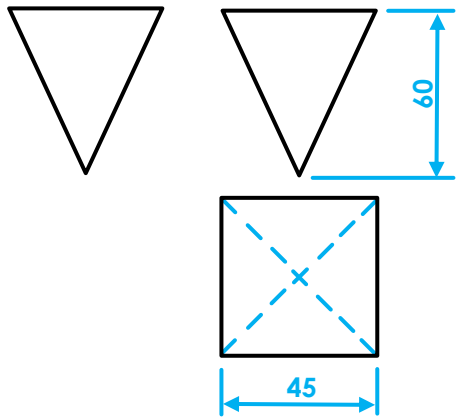

FRONT VIEW

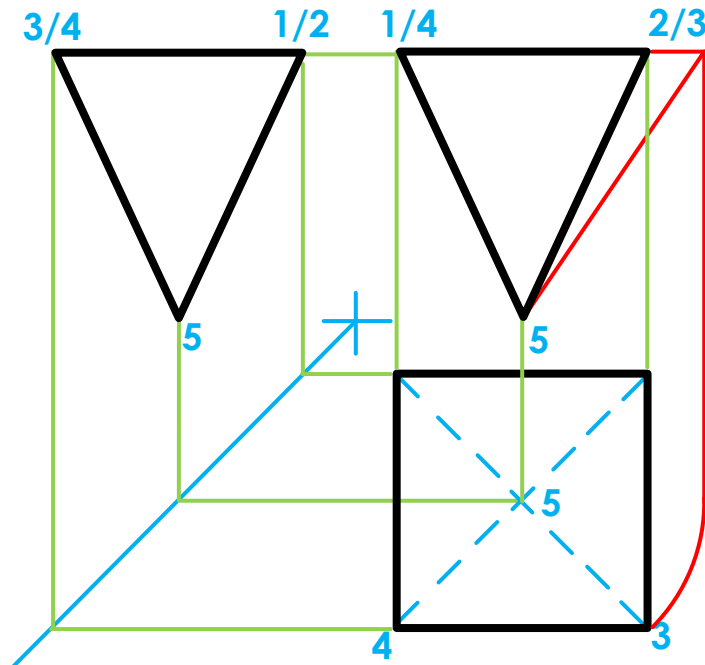

Given:

A regular square pyramid 60 mm high.

Question:

In F.A.O.P. draw...

1. A front view
2. A right view
3. A top view
- 4. Develop the surface of the solid**

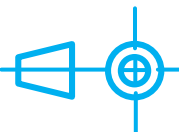

Principles of surface developments

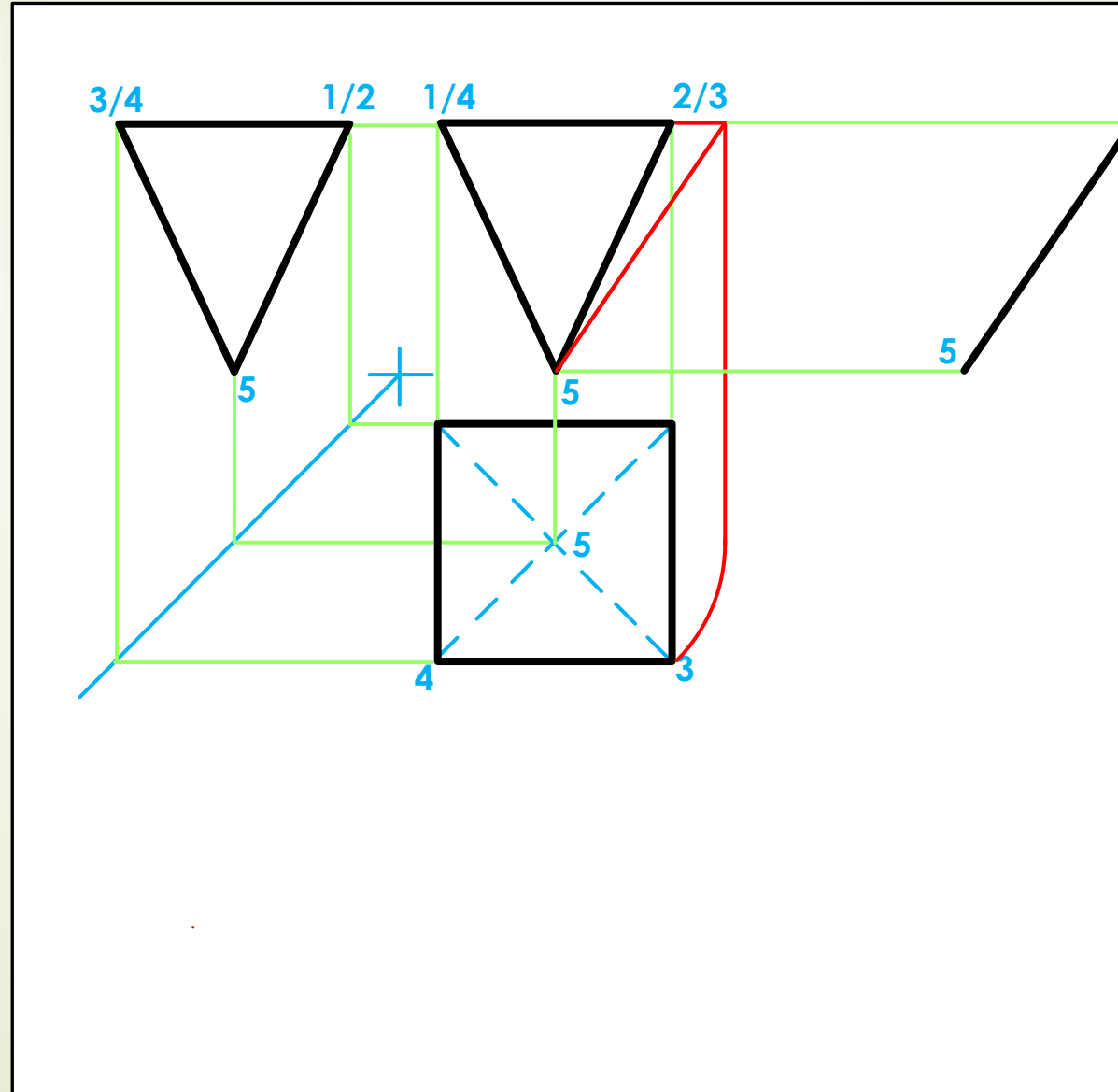
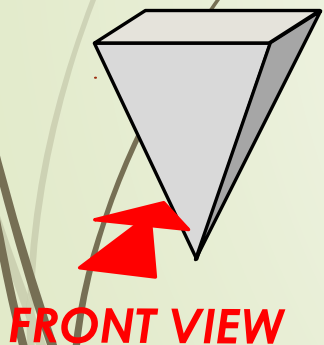
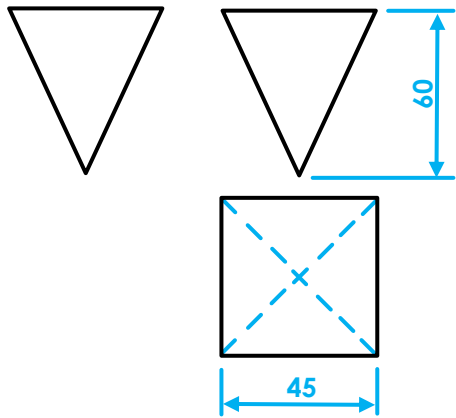

Given:

A regular square pyramid 60 mm high.

Question:

In F.A.O.P. draw...

1. A front view
2. A right view
3. A top view
- 4. Develop the surface of the solid**

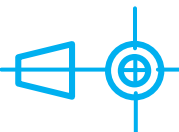

Principles of surface developments

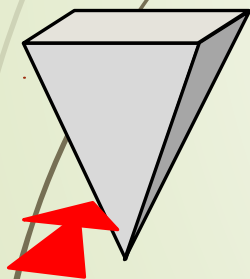
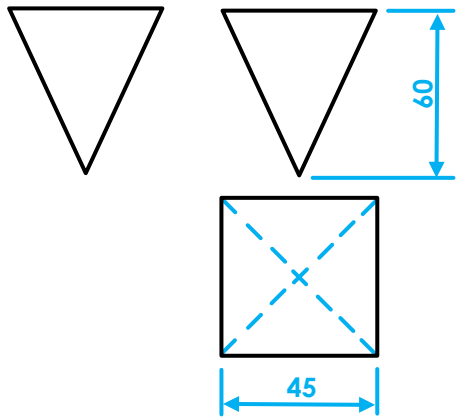

FRONT VIEW

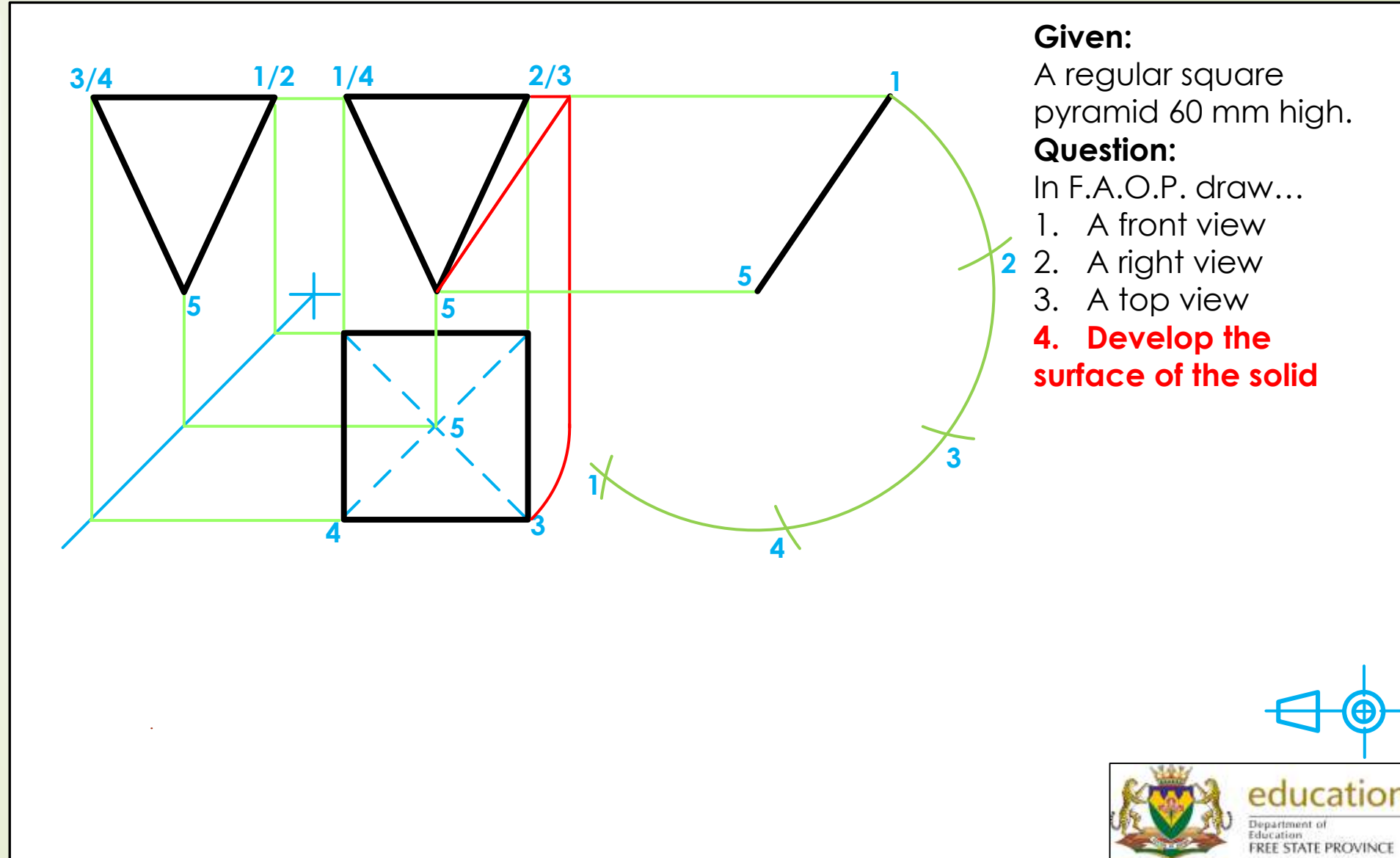

Given:

A regular square pyramid 60 mm high.

Question:

In F.A.O.P. draw...

1. A front view
2. A right view
3. A top view
- 4. Develop the surface of the solid**

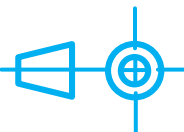

Principles of surface developments

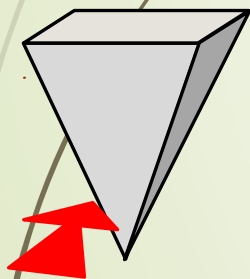
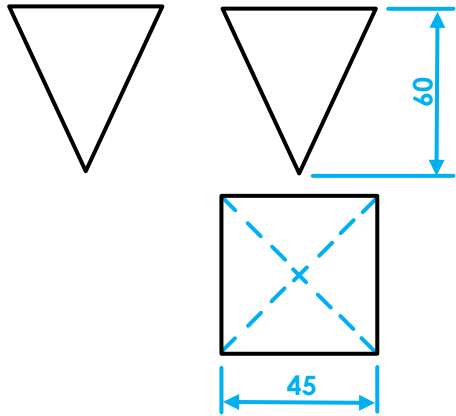

FRONT VIEW

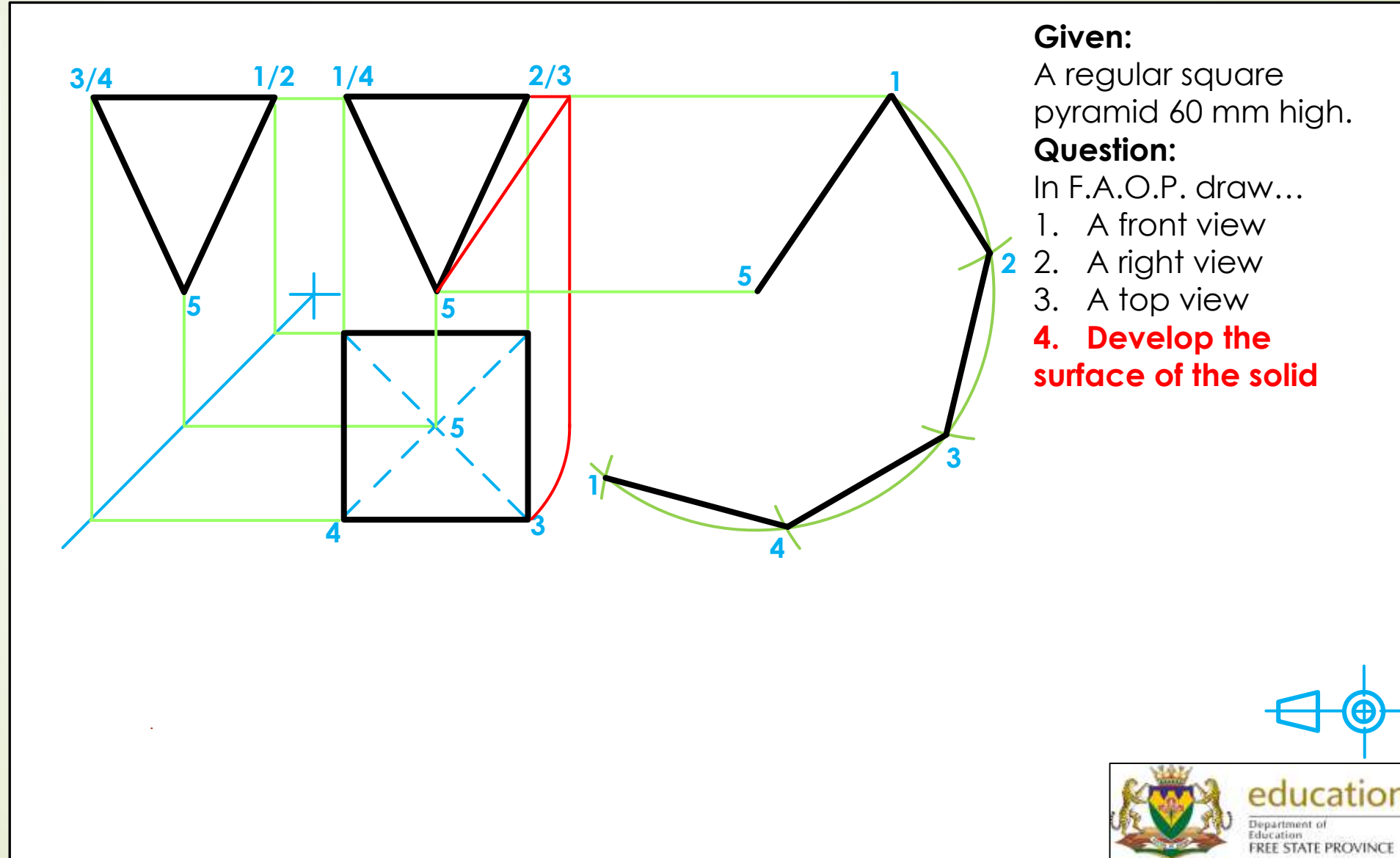

Given:

A regular square pyramid 60 mm high.

Question:

In F.A.O.P. draw...

1. A front view
2. A right view
3. A top view
- 4. Develop the surface of the solid**

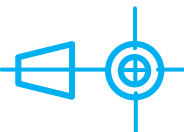

Principles of surface developments

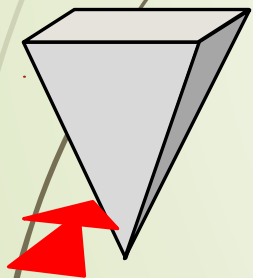
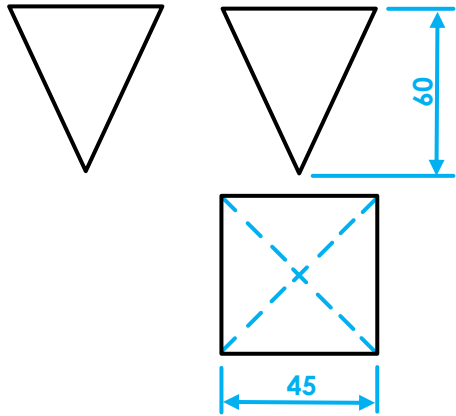

FRONT VIEW

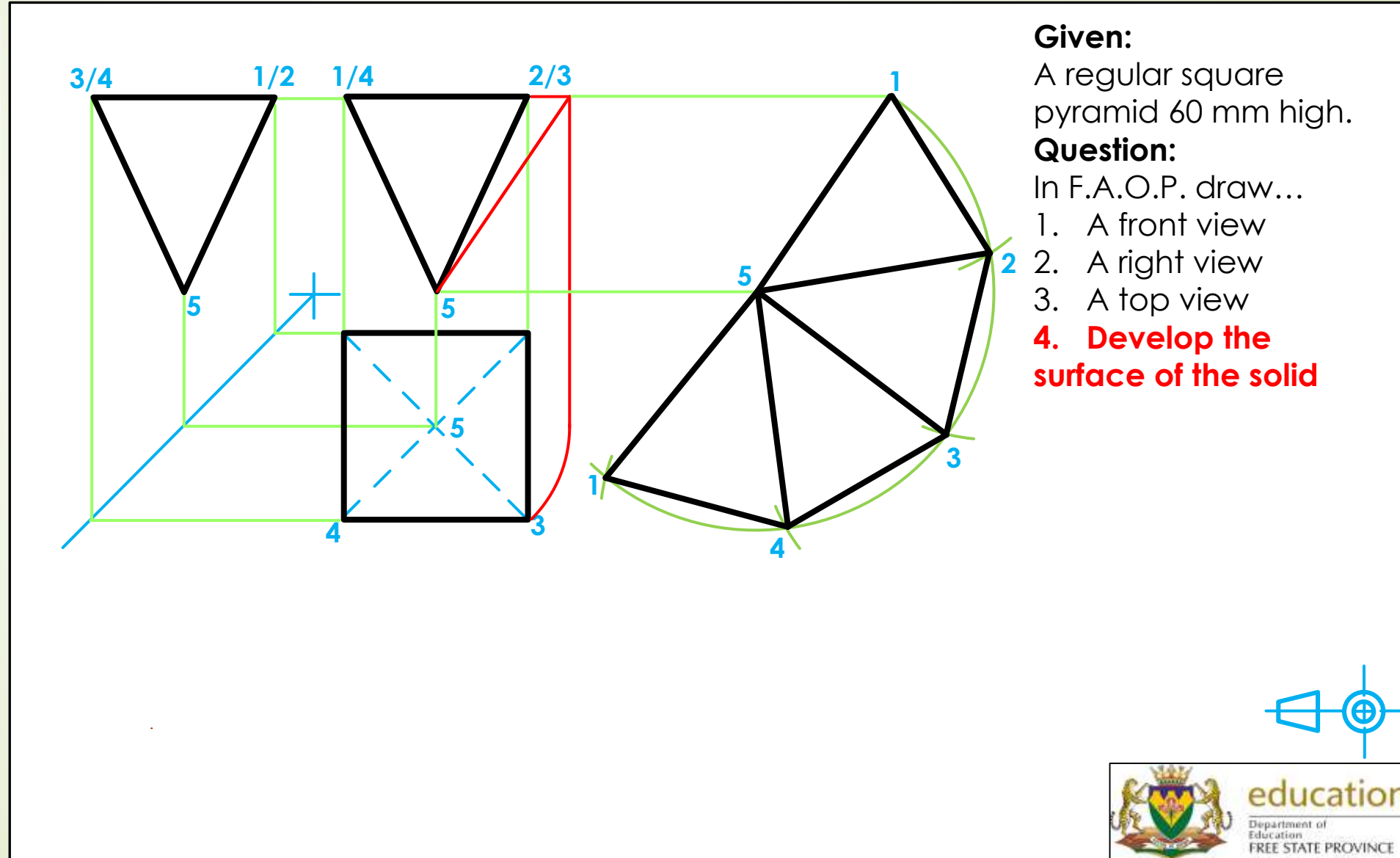

Given:

A regular square pyramid 60 mm high.

Question:

In F.A.O.P. draw...

1. A front view
2. A right view
3. A top view
- 4. Develop the surface of the solid**

