

Interpenetrations

EGD Grade 11 & 12 (Revision)

Developed by: PC Viljoen

Senior Educational Specialist for
Engineering Graphics and Design

Free State Province

Interpenetrations

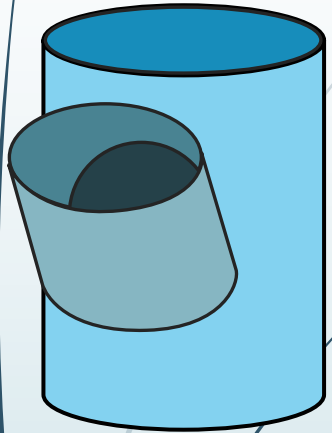

Question 2: Interpenetration

Given:

- * The incomplete front view and top view of a cylinder at 45° that has to fit around another cylinder. The axes of both cylinders lie in a common vertical plane.
- * Auxiliary view of the branch cylinder.

Instructions:

Draw, to scale 1:1, the following:

1. The given top view.
 2. The complete front view clearly showing the curve of interpenetration.
 3. The complete left view.
- * Show ALL hidden detail.
 - * Show ALL necessary construction.

Question 2: Interpenetration

Given:

- * The incomplete front view and top view of a cylinder at 45° that has to fit around another cylinder. The axes of both cylinders lie in a common vertical plane.
- * Auxiliary view of the branch cylinder.

Instructions:

Draw, to scale 1:1, the following:

1. The given top view.
2. The complete front view clearly showing the curve of interpenetration.
3. The complete left view.

- * Show ALL hidden detail.
- * Show ALL necessary construction.

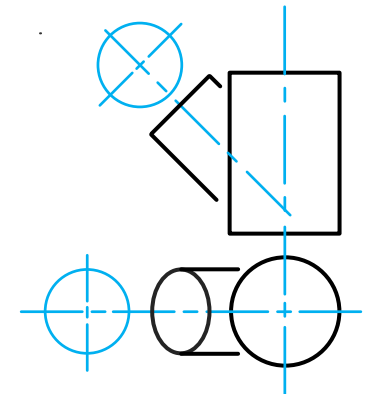

Interpenetrations

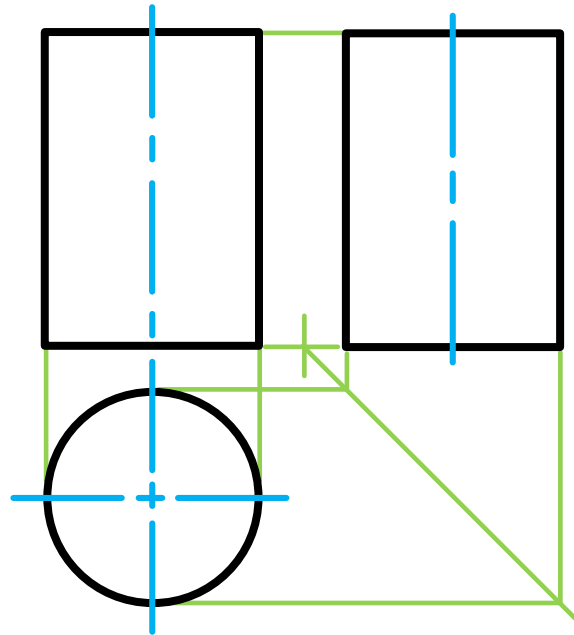
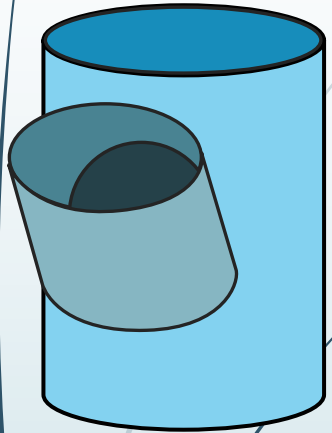

Question 2: Interpenetration

Given:

- * The incomplete front view and top view of a cylinder at 45° that has to fit around another cylinder. The axes of both cylinders lie in a common vertical plane.
- * Auxiliary view of the branch cylinder.

Instructions:

Draw, to scale 1:1, the following:

1. The given top view.
2. The complete front view clearly showing the curve of interpenetration.
3. The complete left view.

* Show ALL hidden detail.

* Show ALL necessary construction.

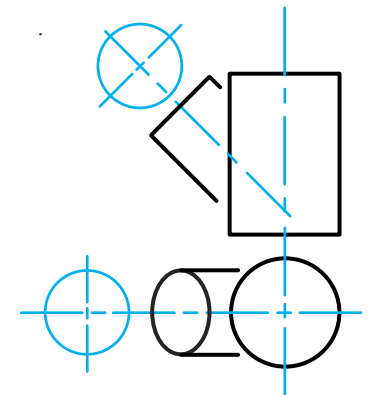

education

Department of
Education
FREE STATE PROVINCE

Interpenetrations

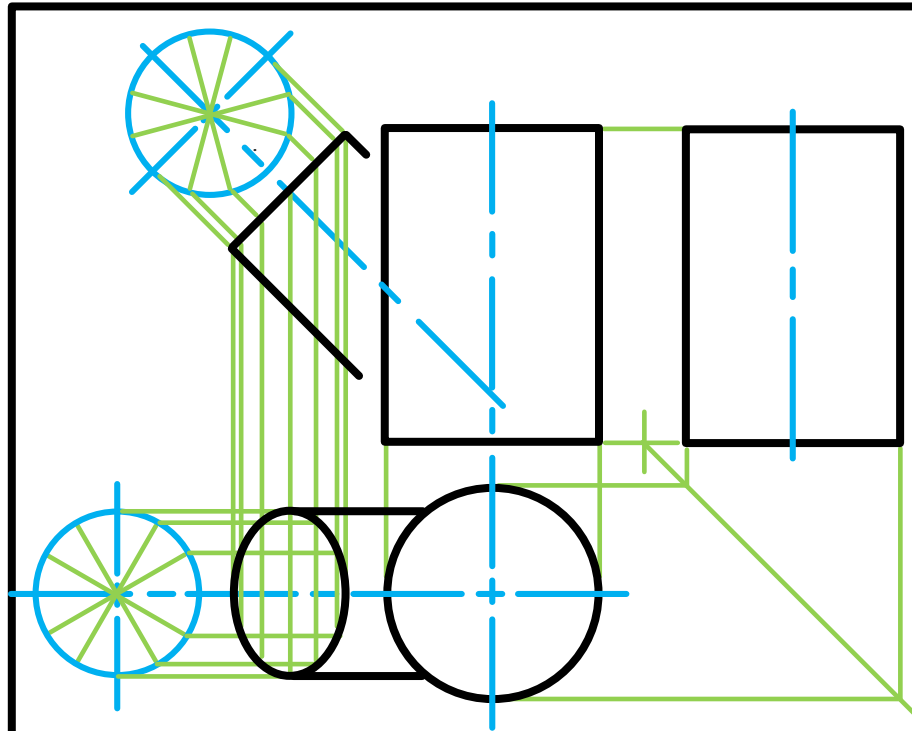
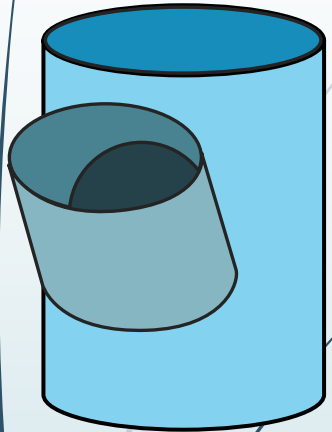

Question 2: Interpenetration

Given:

- * The incomplete front view and top view of a cylinder at 45° that has to fit around another cylinder. The axes of both cylinders lie in a common vertical plane.
- * Auxiliary view of the branch cylinder.

Instructions:

Draw, to scale 1:1, the following:

1. The given top view.
2. The complete front view clearly showing the curve of interpenetration.
3. The complete left view.

* Show ALL hidden detail.

* Show ALL necessary construction.

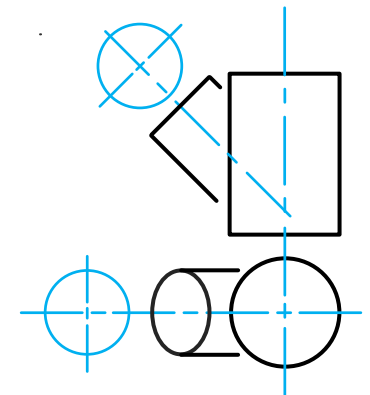

education

Department of
Education
FREE STATE PROVINCE

Interpenetrations

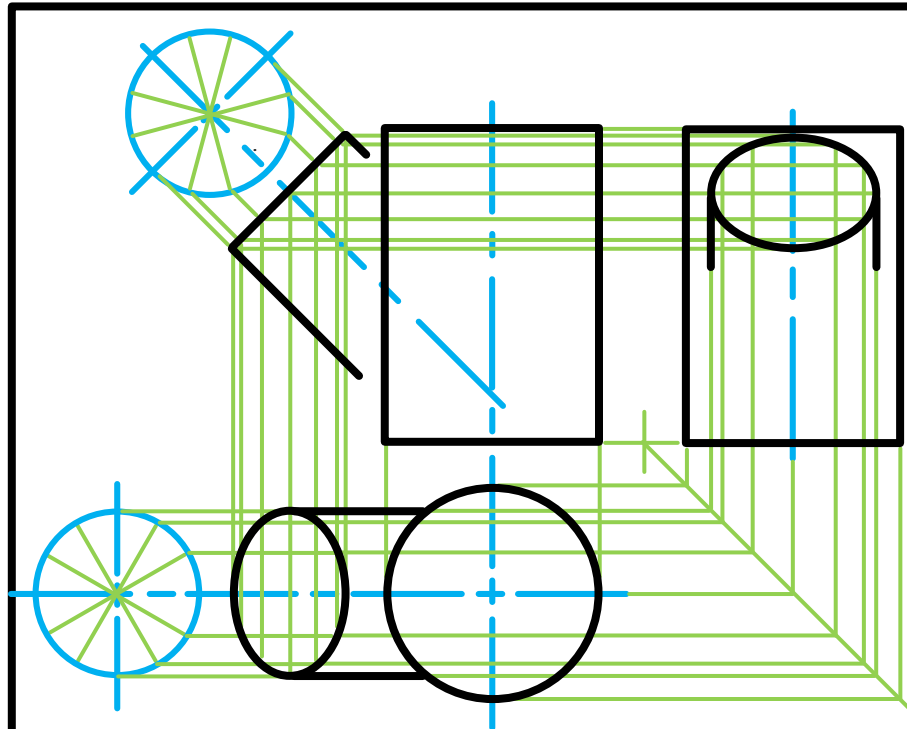
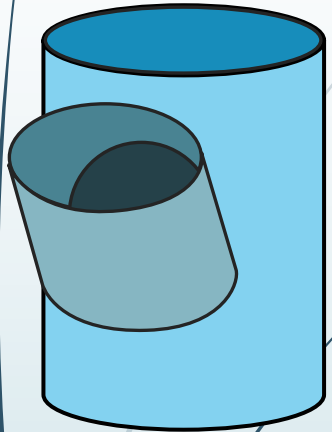

Question 2: Interpenetration

Given:

- * The incomplete front view and top view of a cylinder at 45° that has to fit around another cylinder. The axes of both cylinders lie in a common vertical plane.
- * Auxiliary view of the branch cylinder.

Instructions:

Draw, to scale 1:1, the following:

1. The given top view.
2. The complete front view clearly showing the curve of interpenetration.
3. The complete left view.

* Show ALL hidden detail.

* Show ALL necessary construction.

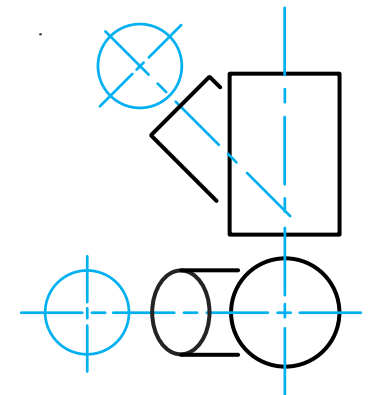

education

Department of
Education
FREE STATE PROVINCE

Interpenetrations

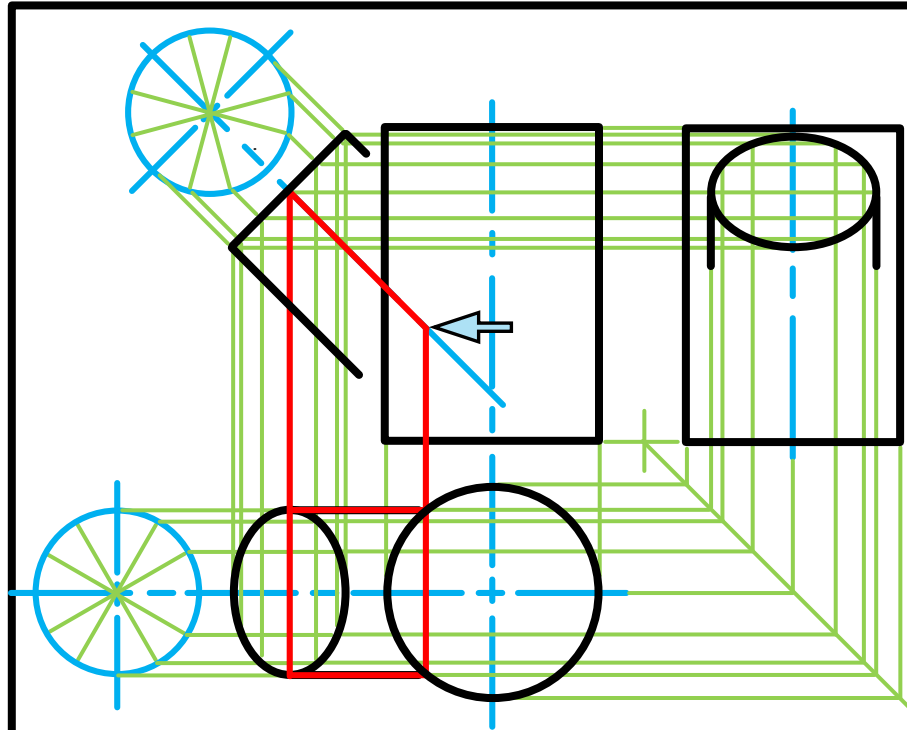
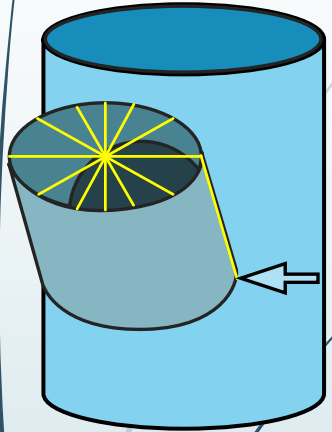

Question 2: Interpenetration

Given:

- * The incomplete front view and top view of a cylinder of 45° that has to fit around another cylinder. The axes of both cylinders lie in a common vertical plane.
- * Auxiliary view of the branch cylinder.

Instructions:

Draw, to scale 1:1, the following:

1. The given top view.
2. The complete front view clearly showing the curve of interpenetration.
3. The complete left view.

* Show ALL hidden detail.

* Show ALL necessary construction.

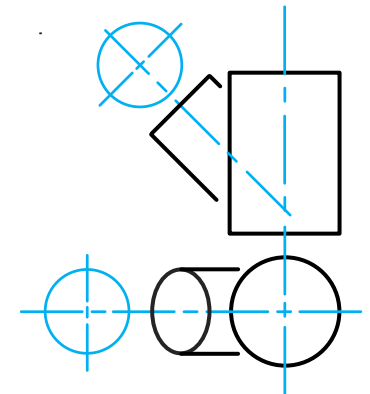

education

Department of
Education
FREE STATE PROVINCE

Interpenetrations

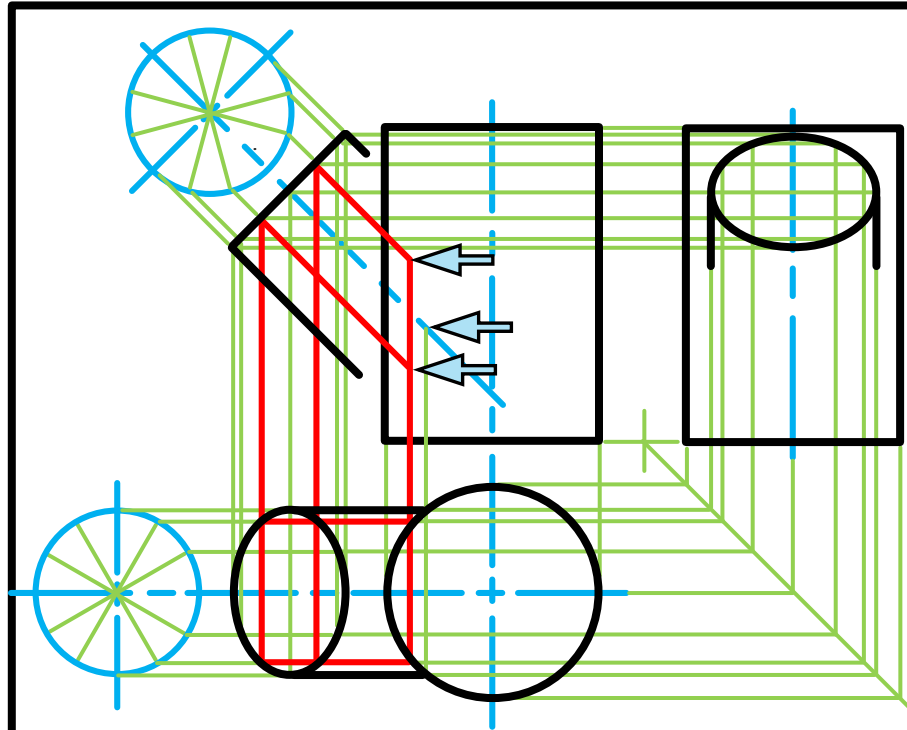
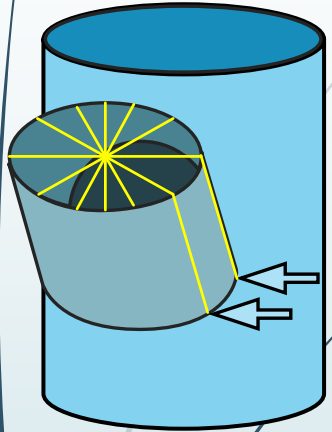

Question 2: Interpenetration

Given:

- * The incomplete front view and top view of a cylinder of 45° that has to fit around another cylinder. The axes of both cylinders lie in a common vertical plane.
- * Auxiliary view of the branch cylinder.

Instructions:

Draw, to scale 1:1, the following:

1. The given top view.
2. The complete front view clearly showing the curve of interpenetration.
3. The complete left view.

* Show ALL hidden detail.

* Show ALL necessary construction.

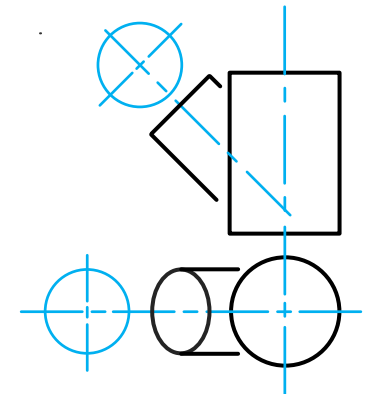

Interpenetrations

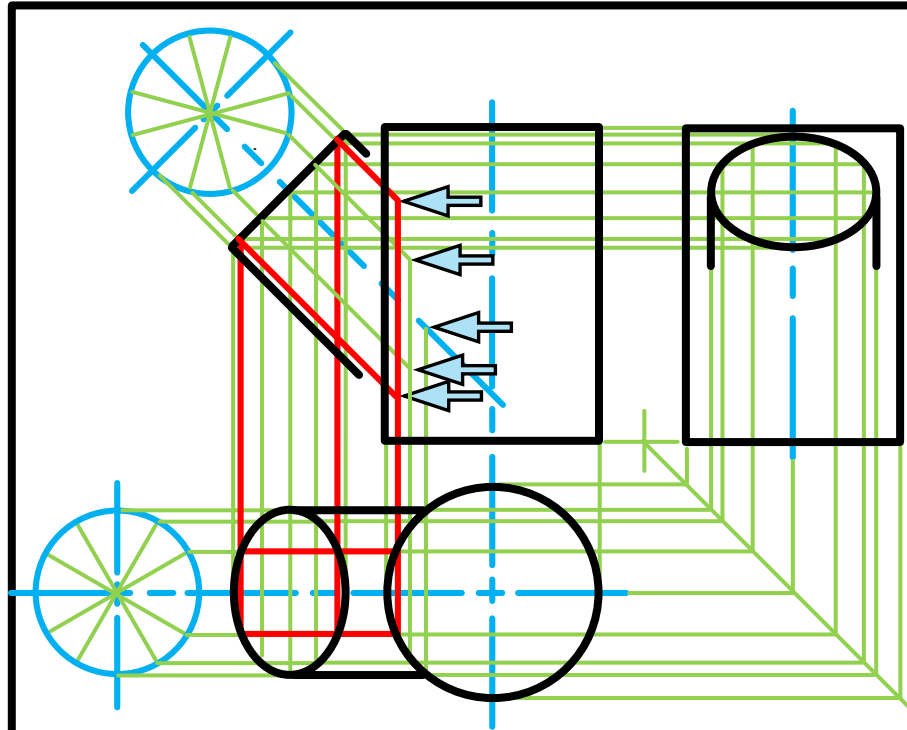
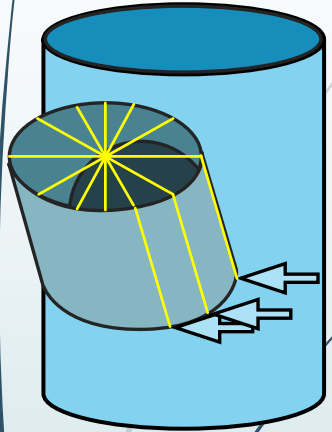

Question 2: Interpenetration

Given:

- * The incomplete front view and top view of a cylinder of 45° that has to fit around another cylinder. The axes of both cylinders lie in a common vertical plane.
- * Auxiliary view of the branch cylinder.

Instructions:

Draw, to scale 1:1, the following:

1. The given top view.
2. The complete front view clearly showing the curve of interpenetration.
3. The complete left view.

* Show ALL hidden detail.

* Show ALL necessary construction.

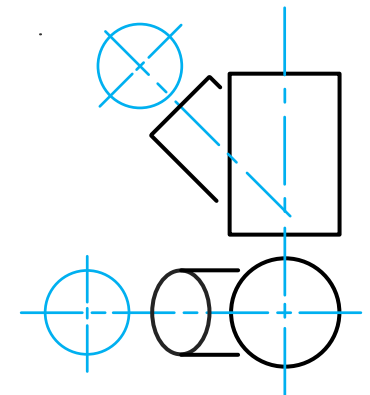

Interpenetrations

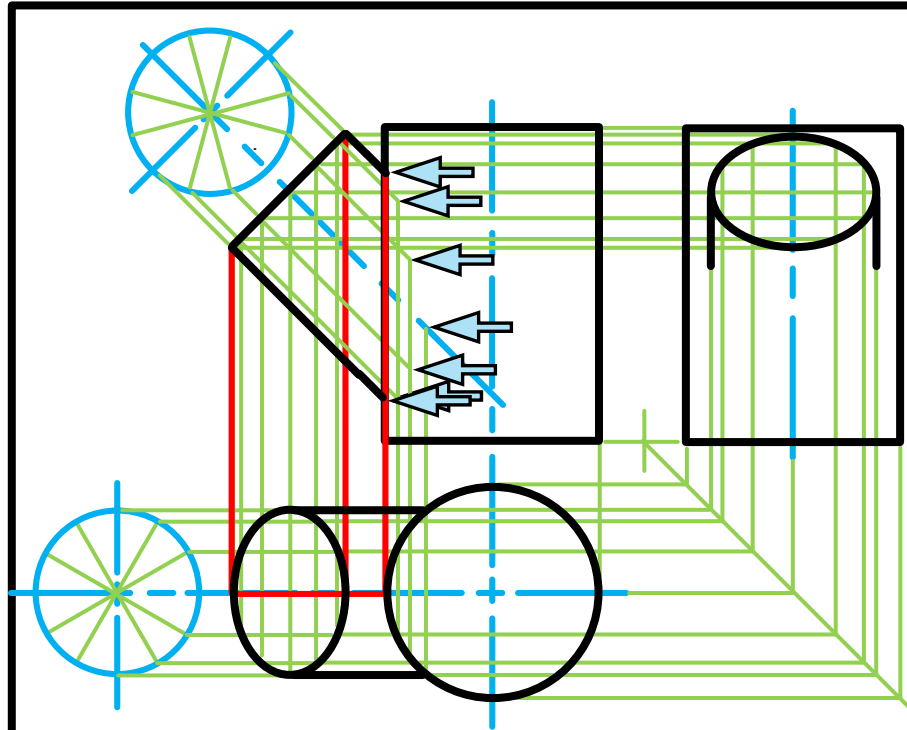
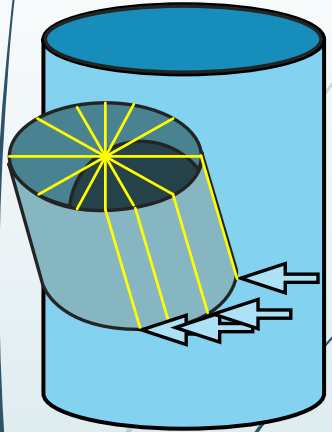

Question 2: Interpenetration

Given:

- * The incomplete front view and top view of a cylinder of 45° that has to fit around another cylinder. The axes of both cylinders lie in a common vertical plane.
- * Auxiliary view of the branch cylinder.

Instructions:

Draw, to scale 1:1, the following:

1. The given top view.
2. The complete front view clearly showing the curve of interpenetration.
3. The complete left view.

* Show ALL hidden detail.

* Show ALL necessary construction.

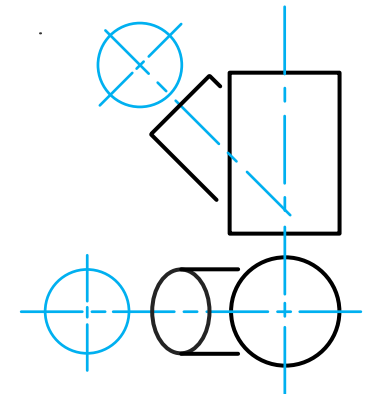

Interpenetrations

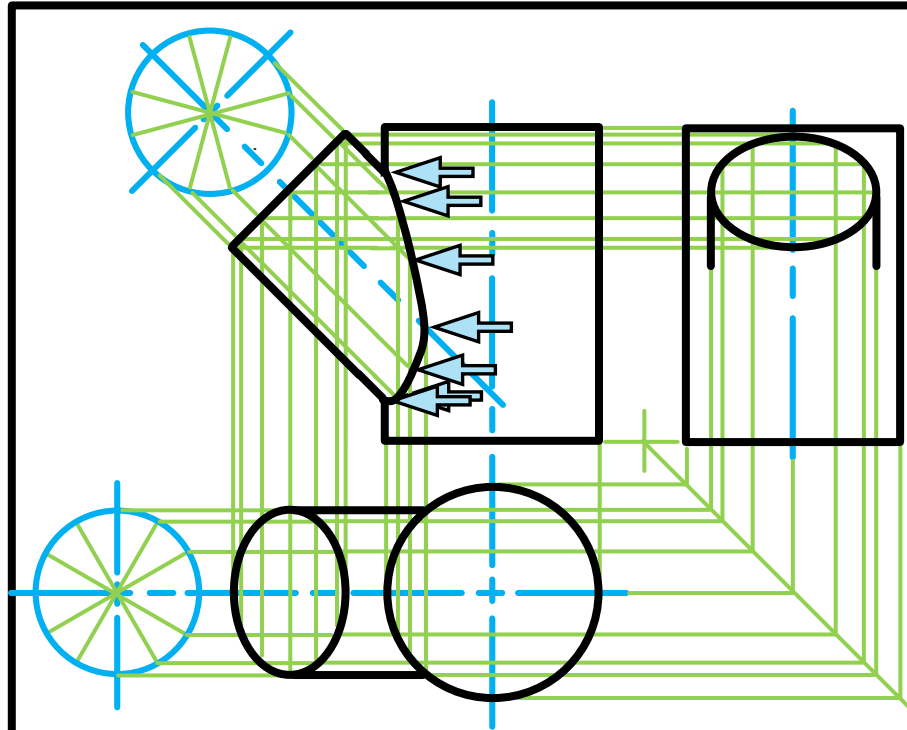
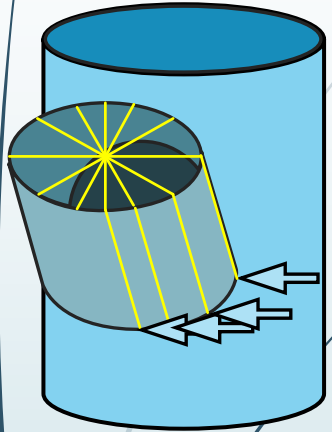

Question 2: Interpenetration

Given:

- * The incomplete front view and top view of a cylinder at 45° that has to fit around another cylinder. The axes of both cylinders lie in a common vertical plane.
- * Auxiliary view of the branch cylinder.

Instructions:

Draw, to scale 1:1, the following:

1. The given top view.
2. The complete front view clearly showing the curve of interpenetration.
3. The complete left view.

* Show ALL hidden detail.

* Show ALL necessary construction.

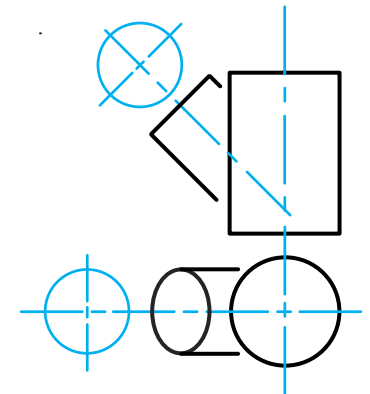

education

Department of
Education
FREE STATE PROVINCE

Interpenetrations

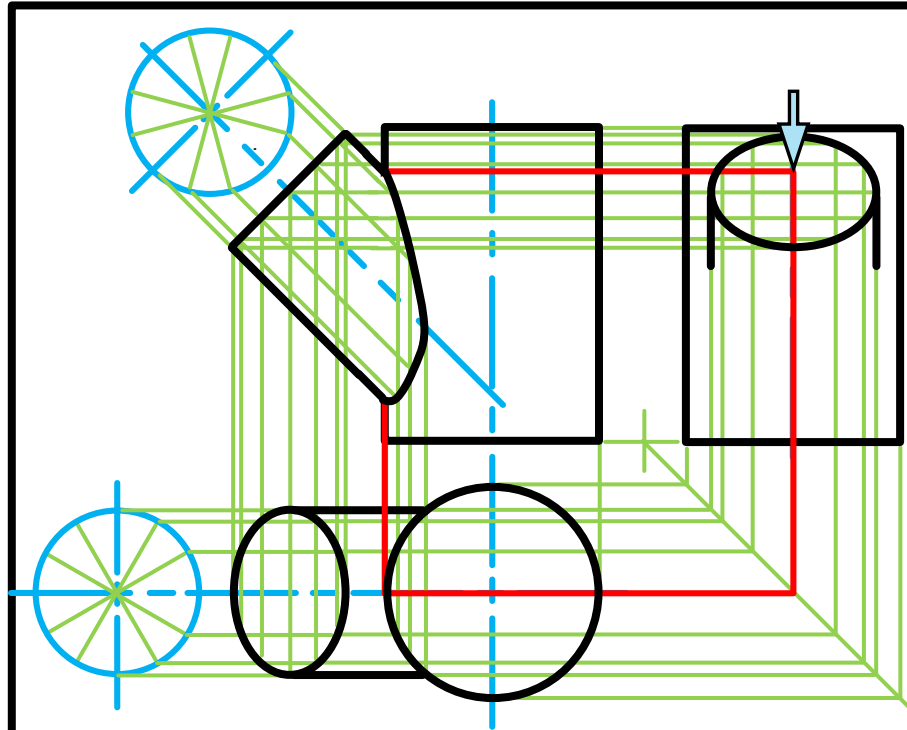
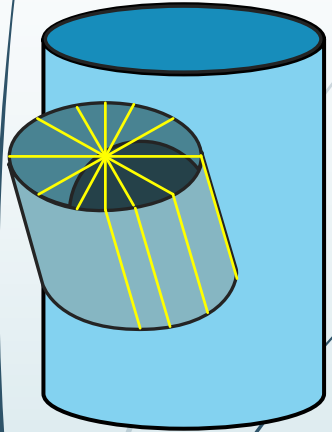

Question 2: Interpenetration

Given:

- * The incomplete front view and top view of a cylinder of 45° that has to fit around another cylinder. The axes of both cylinders lie in a common vertical plane.
- * Auxiliary view of the branch cylinder.

Instructions:

Draw, to scale 1:1, the following:

1. The given top view.
2. The complete front view clearly showing the curve of interpenetration.
3. The complete left view.

* Show ALL hidden detail.

* Show ALL necessary construction.

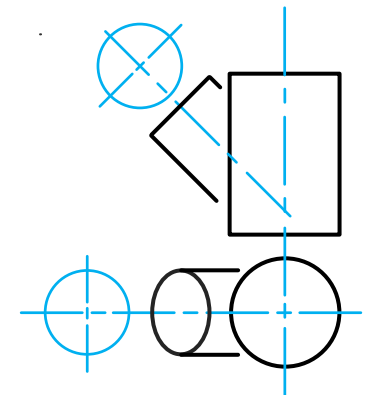

Interpenetrations

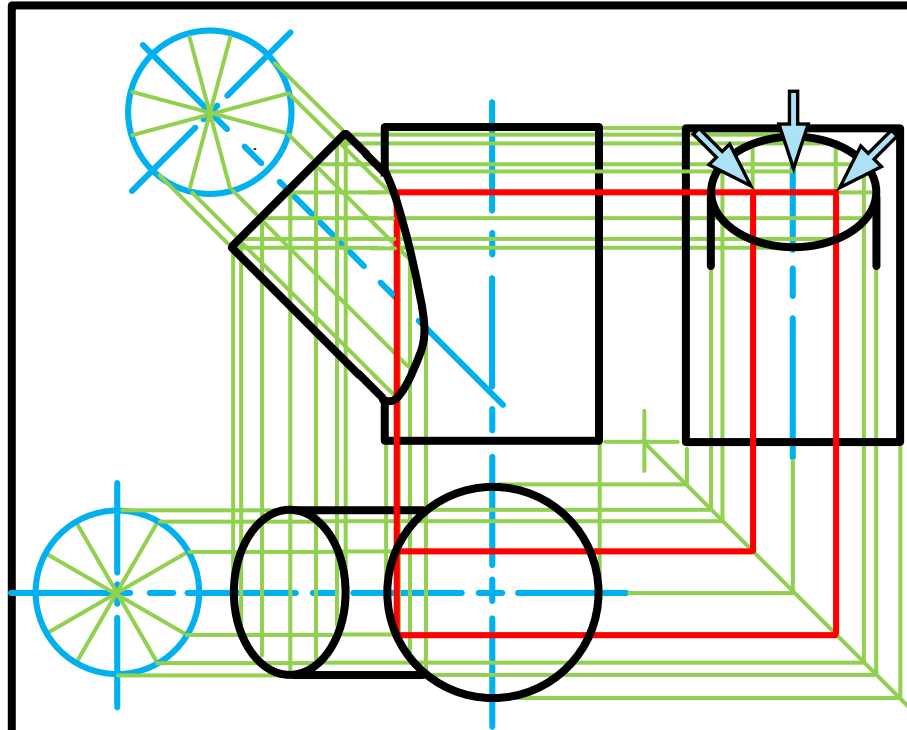
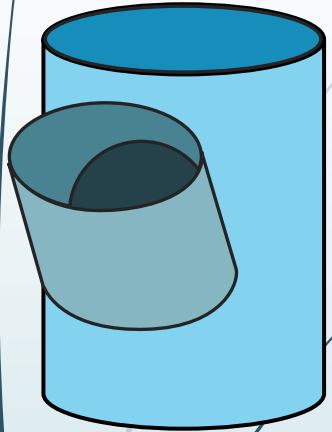

Question 2: Interpenetration

Given:

- * The incomplete front view and top view of a cylinder at 45° that has to fit around another cylinder. The axes of both cylinders lie in a common vertical plane.
- * Auxiliary view of the branch cylinder.

Instructions:

Draw, to scale 1:1, the following:

1. The given top view.
2. The complete front view clearly showing the curve of interpenetration.
3. The complete left view.

* Show ALL hidden detail.

* Show ALL necessary construction.

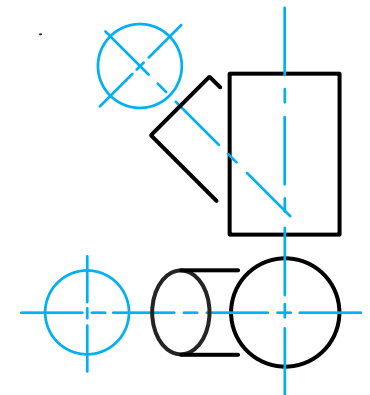

Interpenetrations

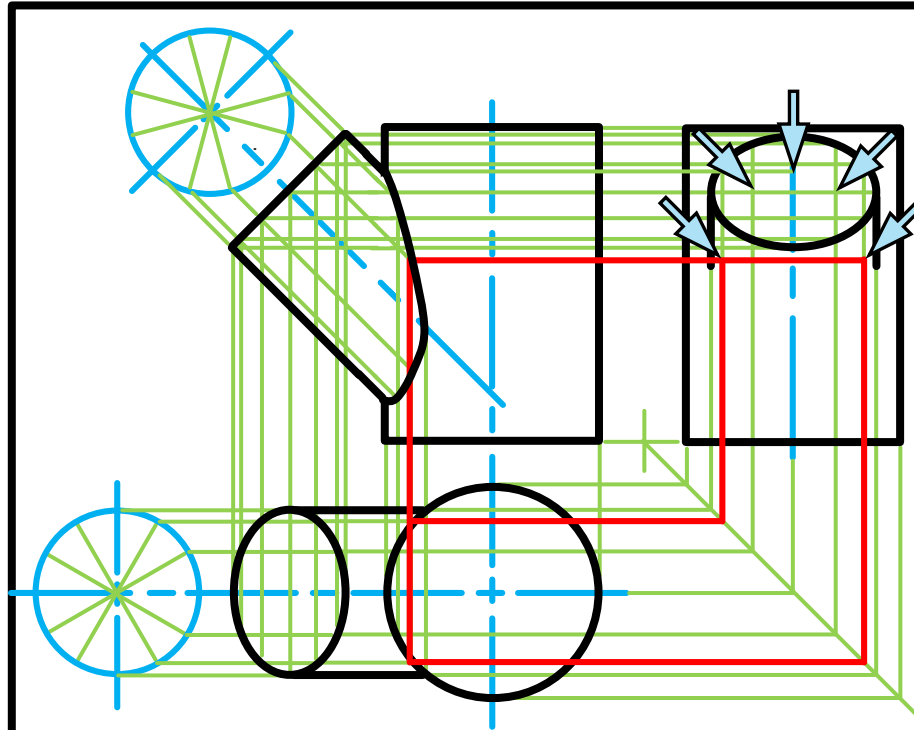
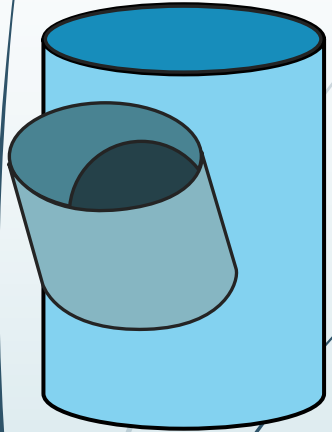

Question 2: Interpenetration

Given:

- * The incomplete front view and top view of a cylinder at 45° that has to fit around another cylinder. The axes of both cylinders lie in a common vertical plane.
- * Auxiliary view of the branch cylinder.

Instructions:

Draw, to scale 1:1, the following:

1. The given top view.
2. The complete front view clearly showing the curve of interpenetration.
3. The complete left view.

* Show ALL hidden detail.

* Show ALL necessary construction.

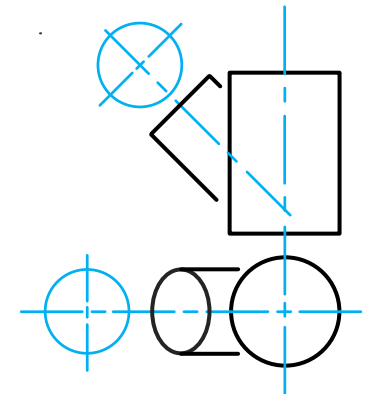

Interpenetrations

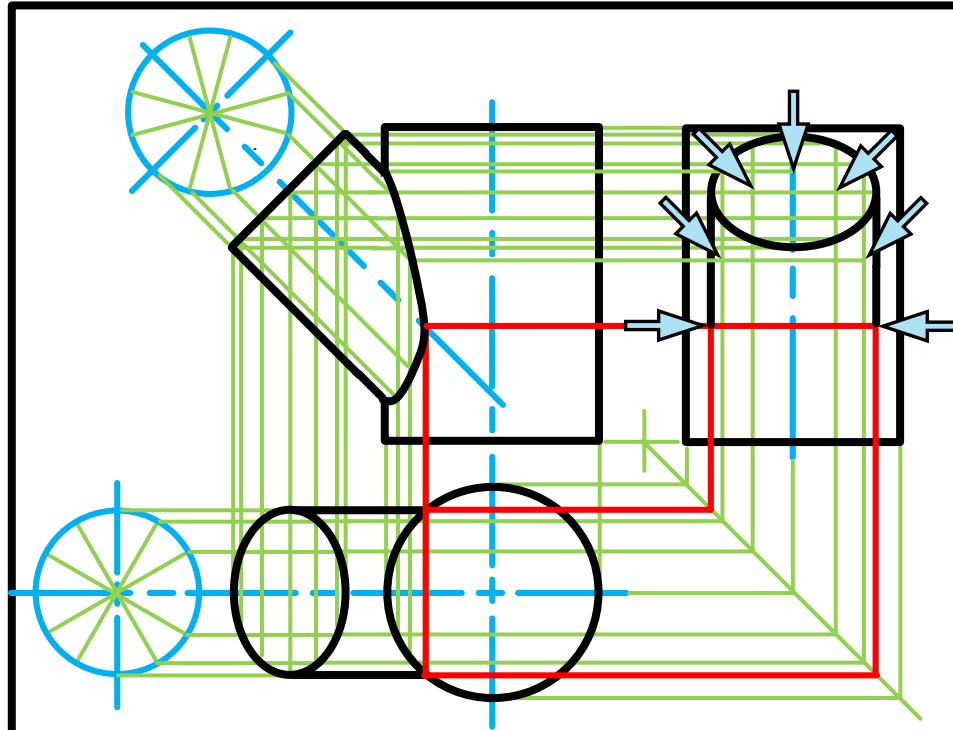
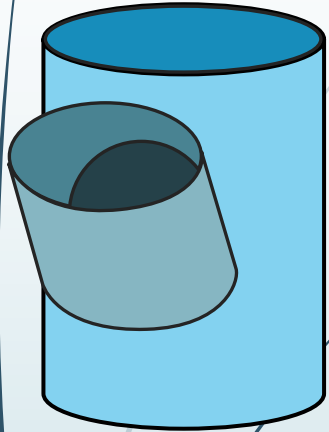

Question 2: Interpenetration

Given:

- * The incomplete front view and top view of a cylinder at 45° that has to fit around another cylinder. The axes of both cylinders lie in a common vertical plane.
- * Auxiliary view of the branch cylinder.

Instructions:

Draw, to scale 1:1, the following:

1. The given top view.
2. The complete front view clearly showing the curve of interpenetration.
3. The complete left view.

* Show ALL hidden detail.

* Show ALL necessary construction.

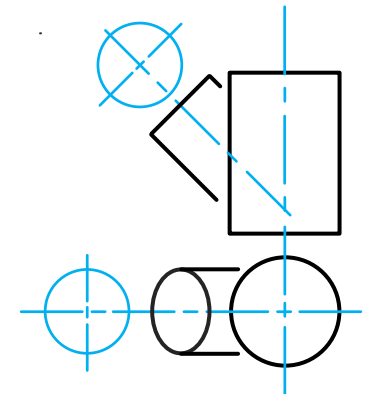

Interpenetrations

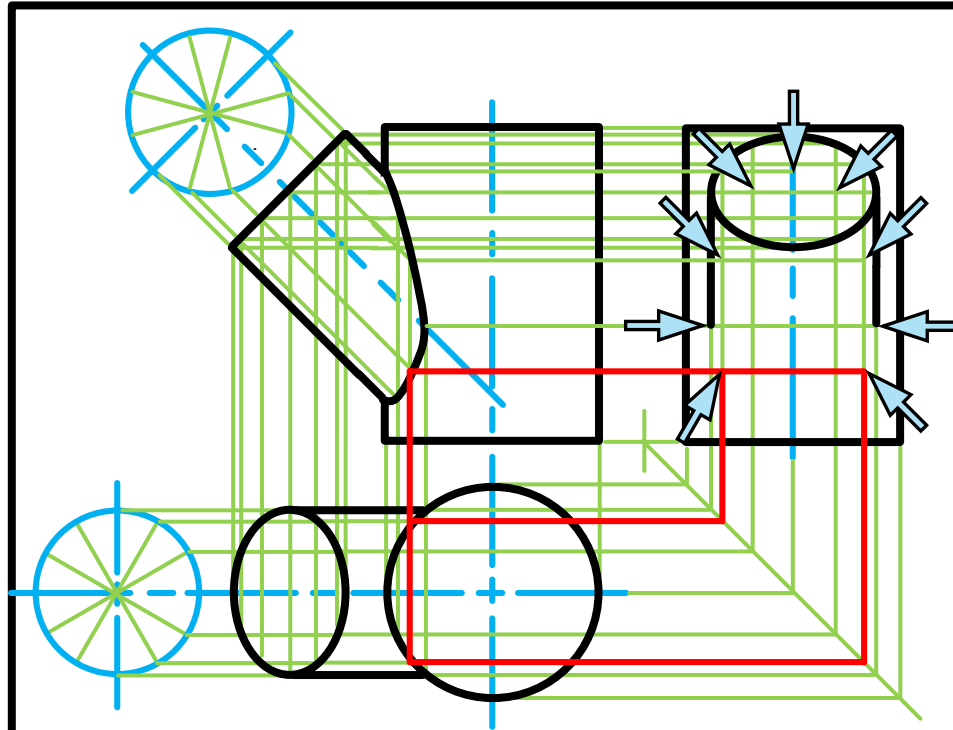
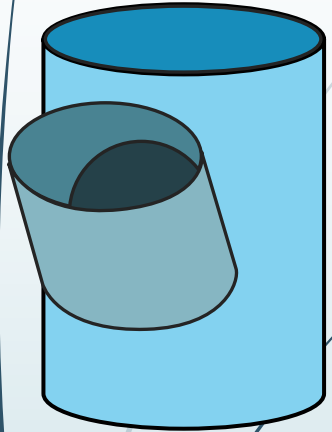

Question 2: Interpenetration

Given:

- * The incomplete front view and top view of a cylinder of 45° that has to fit around another cylinder. The axes of both cylinders lie in a common vertical plane.
- * Auxiliary view of the branch cylinder.

Instructions:

Draw, to scale 1:1, the following:

1. The given top view.
2. The complete front view clearly showing the curve of interpenetration.
3. The complete left view.

* Show ALL hidden detail.

* Show ALL necessary construction.

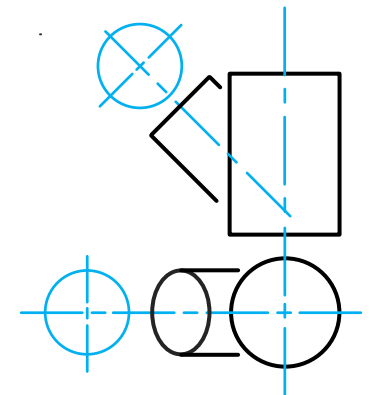

Interpenetrations

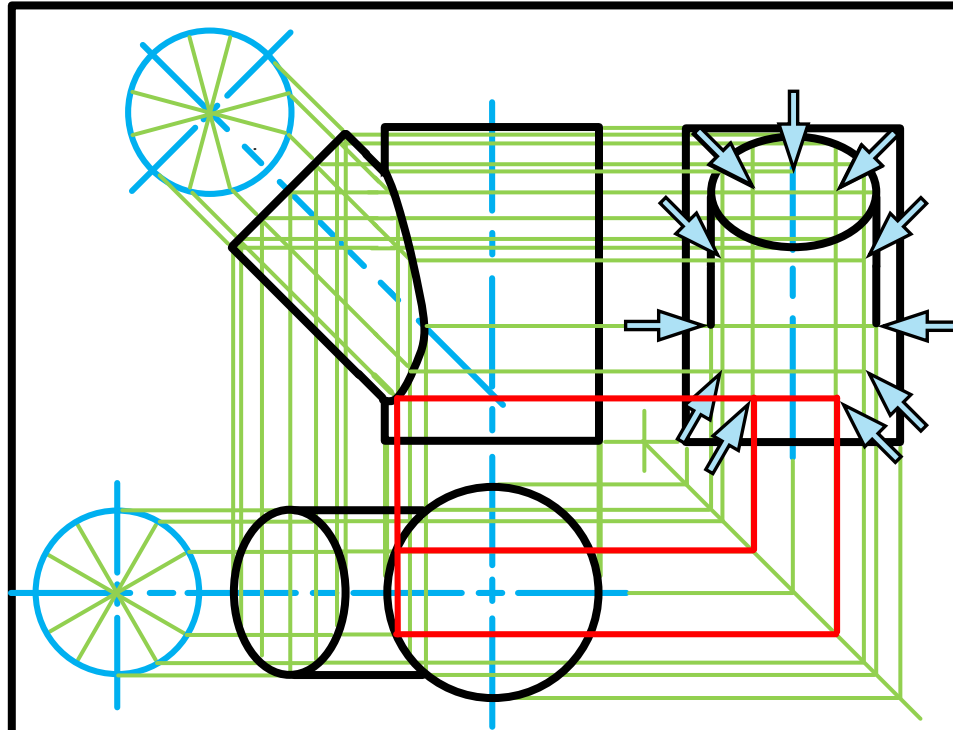
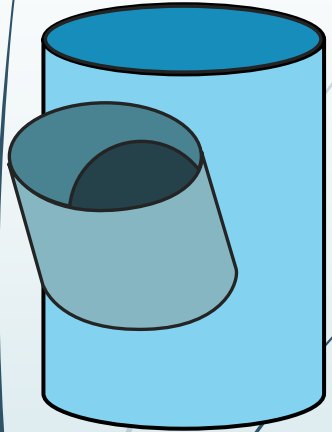

Question 2: Interpenetration

Given:

- * The incomplete front view and top view of a cylinder of 45° that has to fit around another cylinder. The axes of both cylinders lie in a common vertical plane.
- * Auxiliary view of the branch cylinder.

Instructions:

Draw, to scale 1:1, the following:

1. The given top view.
2. The complete front view clearly showing the curve of interpenetration.
3. The complete left view.

* Show ALL hidden detail.

* Show ALL necessary construction.

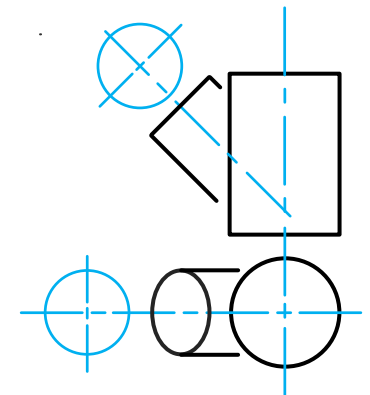

education

Department of
Education
FREE STATE PROVINCE

Interpenetrations

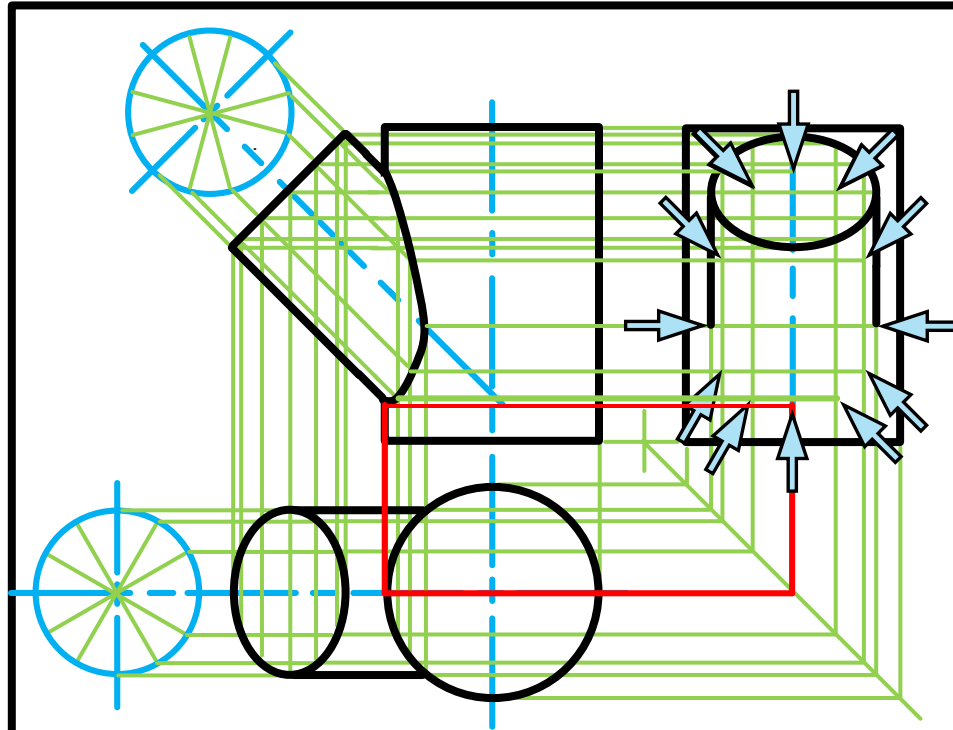
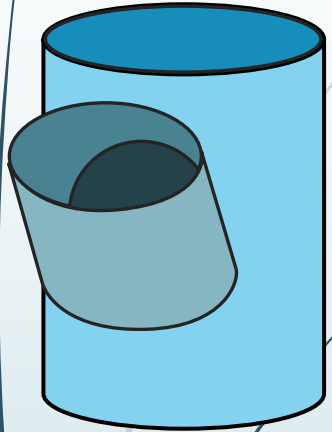

Question 2: Interpenetration

Given:

- * The incomplete front view and top view of a cylinder of 45° that has to fit around another cylinder. The axes of both cylinders lie in a common vertical plane.
- * Auxiliary view of the branch cylinder.

Instructions:

Draw, to scale 1:1, the following:

1. The given top view.
2. The complete front view clearly showing the curve of interpenetration.
3. The complete left view.

* Show ALL hidden detail.

* Show ALL necessary construction.

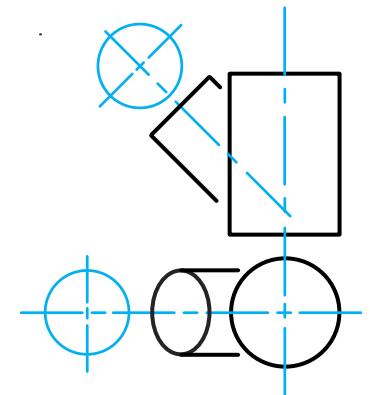

education

Department of
Education
FREE STATE PROVINCE

Interpenetrations

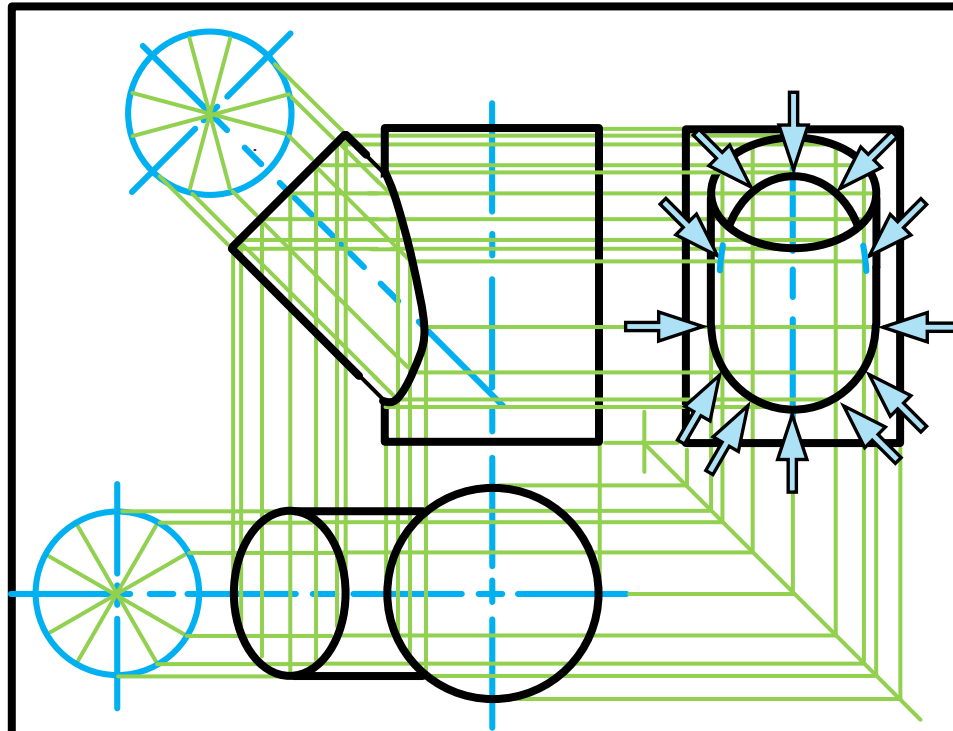
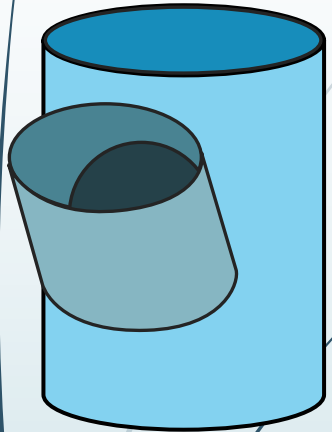

Question 2: Interpenetration

Given:

- * The incomplete front view and top view of a cylinder of 45° that has to fit around another cylinder. The axes of both cylinders lie in a common vertical plane.
- * Auxiliary view of the branch cylinder.

Instructions:

Draw, to scale 1:1, the following:

1. The given top view.
2. The complete front view clearly showing the curve of interpenetration.
3. The complete left view.

* Show ALL hidden detail.

* Show ALL necessary construction.

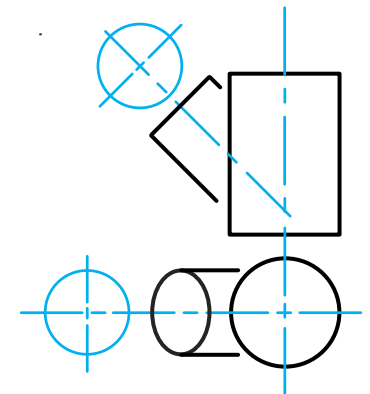

education

Department of
Education
FREE STATE PROVINCE

Interpenetrations

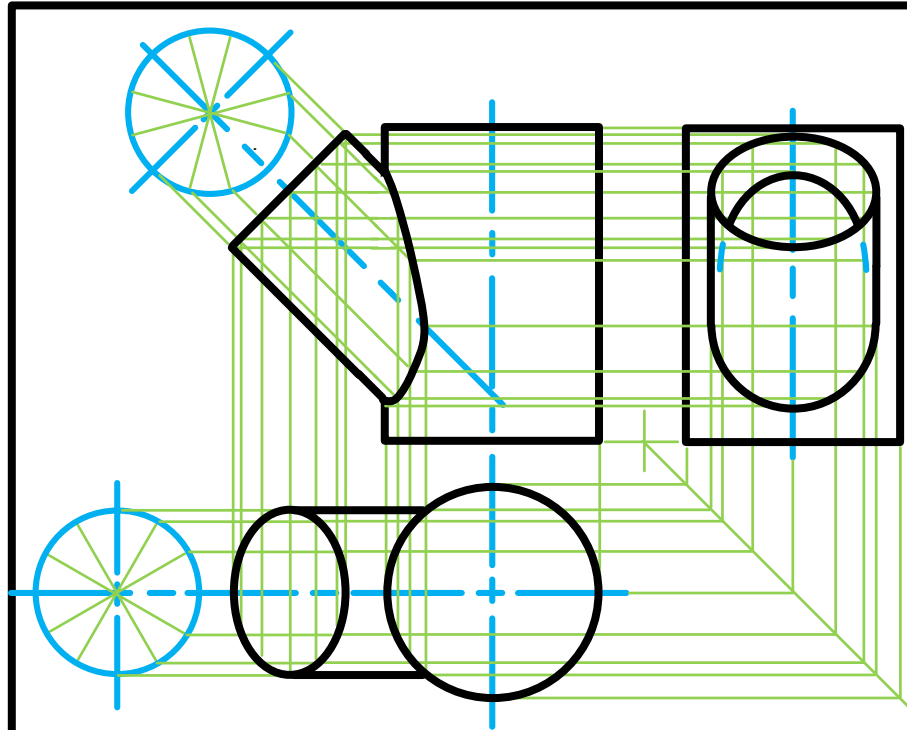
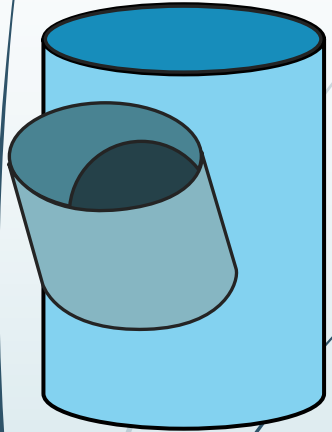

Question 2: Interpenetration

Given:

- * The incomplete front view and top view of a cylinder of 45° that has to fit around another cylinder. The axes of both cylinders lie in a common vertical plane.
- * Auxiliary view of the branch cylinder.

Instructions:

Draw, to scale 1:1, the following:

1. The given top view.
2. The complete front view clearly showing the curve of interpenetration.
3. The complete left view.

* Show ALL hidden detail.

* Show ALL necessary construction.

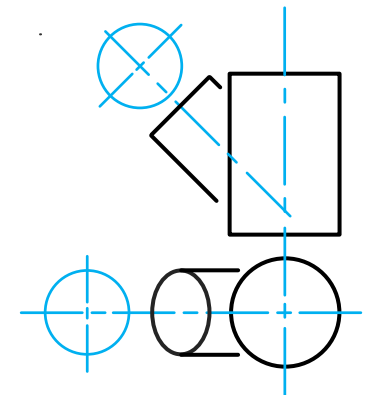

education

Department of
Education
FREE STATE PROVINCE