



# education

Department of  
Education  
FREE STATE PROVINCE

## INGENIEURSGRAFIKA EN ONTWERP ENGINEERING GRAPHICS AND DESIGN

GRAAD 12 / GRADE 12

VRAESTEL 1 / PAPER 1

JUNIE 2019 / JUNE 2019

TYD: 3 URE / TIME: 3 HOURS

TOTAAL: 100 / TOTAL: 100

### INSTRUKSIES EN INLIGTING

1. Beantwoord alle vrae.
2. ALLE tekeninge is in eerstehoekse ortografiese projeksie, tensy anders aangedui.
3. ALLE tekeninge moet volgens skaal 1:1 geteken word, tensy anders aangedui.
4. AL die vrae moet soos voorgeskryf op DIAGRAMVEL beantwoord word.
5. AL die bladsye moet weer in nommervolgorde vasgekram word, ongeag of die vraag beantwoord is of nie.
6. Tydsbeplanning is noodsaaklik om al die vrae te voltooi.
7. Drukskryf jou naam en van asook die graad in die spasie wat voorsien is op elke bladsy.
8. ALLE antwoorde moet akkuraat en netjies geteken word.
9. ALLE nodige konstruksie- en projeksielyne moet getoon word.
10. Beplan elke tekening noukeurig vanaf die beginposisie wat aangedui is op die diagramvelle.
11. Enige besonderhede of afmetings wat nie gegee is nie, moet in goeie verhouding beraam word.

### INSTRUCTIONS AND INFORMATION

1. Answer all the questions.
2. ALL drawings are in first-angle orthographic projection, unless stated otherwise.
3. ALL drawings must be drawn to scale 1:1, unless stated otherwise.
4. ALL questions must be answered on the DIAGRAM SHEET as instructed.
5. ALL the pages must be restapled in numeric sequence, irrespective of whether the question was attempted or not.
6. Time management is essential in order to complete all the questions.
7. Print your name and surname as well as the grade in the space provided on each page.
8. ALL answers must be drawn accurately and neatly.
9. ALL necessary construction and projection lines must be shown.
10. Plan each drawing carefully from the given position, which is indicated on the diagram sheets.
11. Any details or dimensions not given must be assumed in good proportion.

SLEGS VIR AMPTELIKE GEBRUIK FOR OFFICE USE ONLY								
PUNTE / MARKS				MODEREER MODERATE				
1								
2								
3								
4								
TOTAAL TOTAL								
			2	0	0			
			2	0	0			

FINALE PUNT FINAL MARK	NAGESIEN CHECKED
100	

NAAM & VAN NAME & SURNAME		GRAAD GRADE	
------------------------------	--	----------------	--

LANDMETERSERTIFIKAAT VAN DIE GRENSLENGTES EN HOEKHOOGTES VIR ERF 3. OPGEMEET OP 25-11-2016	
LAND SURVEYOR'S CERTIFICATE OF THE BOUNDARY LENGTHS AND CORNER HEIGHTS ON STAND 3. SURVEYED ON 25-11-2016	
GRENSLENGTES IN MILLIMETER BOUNDARY LENGTHS IN MILLIMETERS	HOEKHOOGTES IN METER CORNER HEIGHTS IN METERS
AB = 74569	A = 1780,6
BC = 116000	B = 1780,7
CD = 74569	C = 1779,7
DA = 116000	D = 1779,3

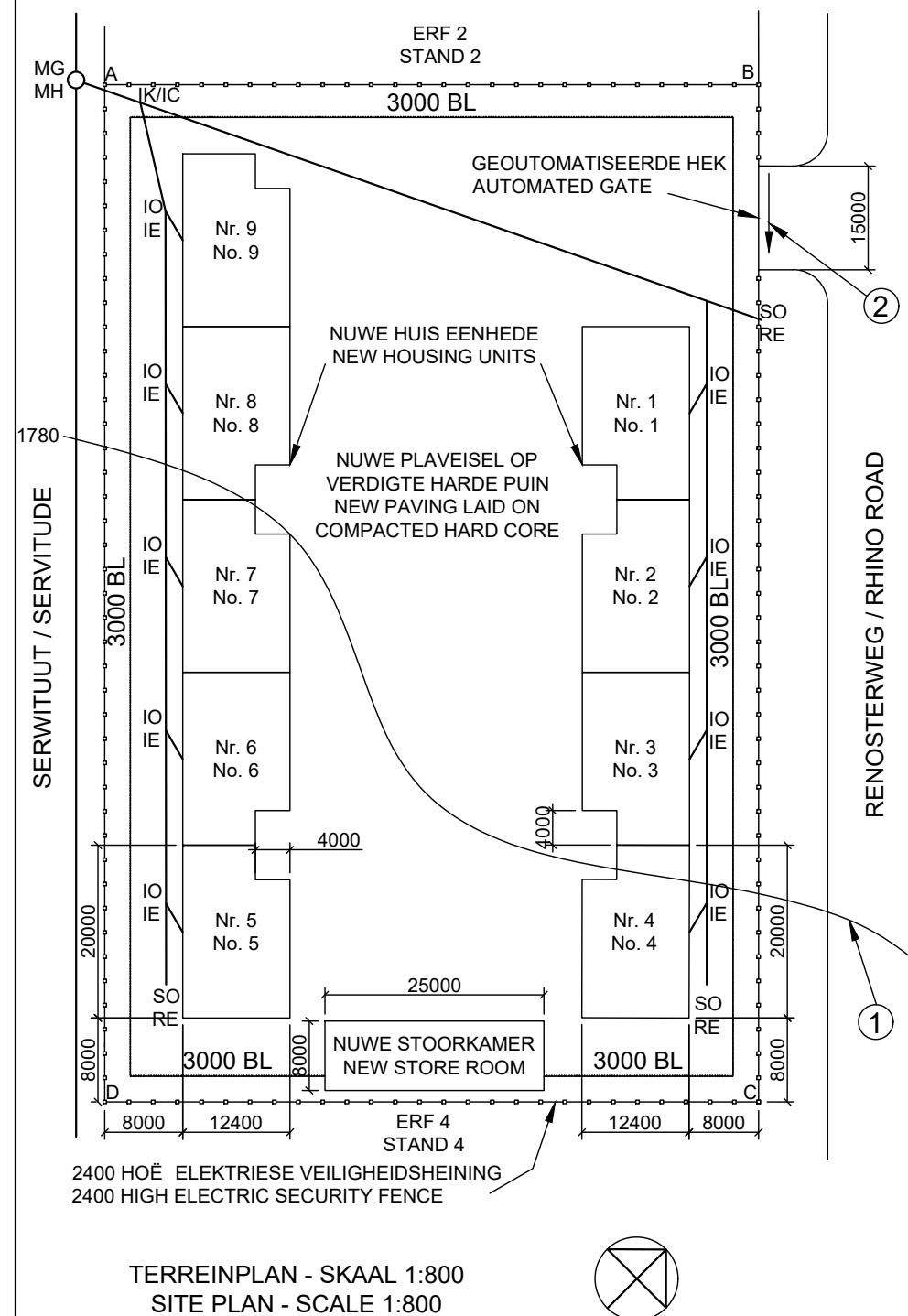

**VRAAG 1 ANALITIES (SIVIEL)**  
**QUESTION 1 ANALYTICAL (CIVIL)**

Gegee: Terreinplan en 'n titelpaneel word getoon.  
Instruksies: Voltooi die tabel deur die vrae wat na die bygaande tekening en titelpaneel verwys, netjies te beantwoord. DRUKSKRYF in POTLOOD in die voorbereide kolom.

Given: Site plan and a title panel are shown.  
Instructions: Complete the table by neatly answering the questions, which refer to the accompanying drawing and title panel. PRINTING in PENCIL in the prepared column.

**NOTA:**  
Kontrakteurs moet alle afmetings en hoogtes op die terrein bevestig voordat daar met die werk begin word. Argitekte moet onmiddellik van enige afwykings in kennis gestel word.

**NOTE:**  
Contractors must verify all dimensions and levels on site before commencing work. Architects to be notified immediately of any discrepancies.

ARGITEK SE HANDTEKENING  
ARCHITECTS SIGNATURE .....

KLIËNT SE HANDTEKENING  
CLIENT'S SIGNATURE .....

**OOSKUS ARGITEKTE  
EAST COAST ARCHITECTS**

HOOFWEG 125 DURBAN 9876  
inligting@oka.co.za

125 MAIN ROAD DURBAN 9876  
info@eka.co.za

DATUM GETEKEN DATE DRAWN	GETEKEN DEUR DRAWN BY	
2017-03-16	JOHANN	
GEDRUK DEUR: L & K DRUKKERS PRINTED BY: L & K PRINTERS	DRUKDATUM DATE PRINTED	
	2017-04-08	
PROJEK VOORGESTELDE NUWE BEHUISINGS- EENHEDE IN 'N VEILIGHEIDSKOMPLEKS OP ERF 3, RENOSTERWEG, UITKYKPARC.		
PROJECT PROPOSED NEW HOUSING UNITS IN A SECURITY COMPLEX ON STAND 3, RHINO ROAD, OBSERVATION PARK		
NAGESIEN DEUR CHECKED BY	DATUM VAN HERSIEN DATE OF REVISION	
JAN	2017-04-20	
VERWYSINGSKODE REFERENCE CODE	PROJEKNOMMER PROJECT NUMBER	TEKENINGNOMMER DRAWING NUMBER
Q1P1N2017	NOVP12017	JB140417

NO	VRAE / QUESTIONS	ANTWOORDE / ANSWERS	E	M
1	Hoeveel handtekeninge word benodig? How many signatures are required?		1	
2	Wie het die tekening voorberei? Who prepared the drawing?		1	
3	Watter skaal word vir die tekening aangedui? What scale is indicated for the drawing?		1	
4	Wie het die tekening nagesien? Who checked the drawing?		1	
5	Wie was verantwoordelik vir die druk van die terreinplan? Who was responsible for the printing of the site plan?		1	
6	Wanneer is die terrein opgemeet? When was the site surveyed?		1	
7	Hoeveel steekoë word op die terreinplan getoon? How many rodding eyes are shown on the site plan?		1	
8	Waarvoor staan die afkorting IK? What does the abbreviation IC stand for?		1	
9	In watter kleur behoort nuwe glas op 'n gedetailleerde tekening aangedui te word? In what colour should new glass be indicated on a detailed drawing?		1	
10	Noem die kenmerk by 1. Name the feature at 1.		1	
11	In watter eenheid is die afmeting op die terreinplan? In what unit are the dimensions on the site plan?		1	
12	Waarop moet die nuwe plaveisel gelê word? On what must the new paving be laid?		2	
13	Watter tipe heining word vir die kompleks voorgestel? What type of fence is proposed for the complex?		2	
14	Wat word deur die pyl by 2 aangedui? What is indicated by the arrow at 2?		1	
15	Hoekom sou 'n residensiële ontwikkeling nie op die grond direk Suidwes van ERF 3 toegelaat word nie? Why would a residential development not be allowed on the land immediately South-West of STAND 3?		2	
16	Met verwysing na die bouregulasies, hoekom sou hierdie voorgestelde terreinplan nie goedgekeur word nie? Referring to the building regulations, why would this proposed site plan not be approved?		2	
17	Teken, vryhand, die vooraansig en bo-aansig van die SABS-konvensiesimbool vir 'n bad in die voorsiene spasie. In the space provided, draw freehand, the front view and top view of the SANS convention for a bath		9	
TOTAAL TOTAL			29	

**VRAAG 17  
QUESTION 17**

Teken, vryhand, die vooraansig en bo-aansig van die SABS-konvensiesimbool vir die bad in die voorsiene spasie.

In the space provided, draw freehand, the front view and top view of the SANS convention for a bath.

**VRAAG 2: INTERPENETRASIE EN ONTWIKKELING**

**QUESTION 2: INTERPENETRATION AND DEVELOPMENT**

**Gegee:**

- Die onvolledige vooraansig en booaansig van 'n gelyksydige driehoekige prisma wat gevorm is om rondom 'n regte reëlmatige seskantige prisma te pas. Die asse van beide prisma's lê in 'n gemeenskaplike vertikale vlak.
- 'n Hulpaansig van die driehoekige prisma.

**Given:**

- The incomplete front view and top view of an equilateral triangular prism that has been shaped to fit around a right regular hexagonal prism. The axes of both prisms lie in a common vertical plane.
- An auxiliary view of the triangular prism.

**Instruksies:**

Teken volgens skaal 1 : 1, die volgende:

- 2.1 Die gegewe booaansig volgens Punt S.
- 2.2 Die volledige vooraansig wat die deurdringingskromme duidelik toon.
- 2.3 Die volledige regteraansig.
- 2.4 Die ontwikkeling van die oppervlak van die driehoekige prisma. Maak AB die naat.

**Instructions:**

Draw, to scale 1 : 1, the following:

- 2.1 The given top view according to Point S.
- 2.2 The complete front view clearly showing the curve of interpenetration.
- 2.3 The complete right view.
- 2.4 The development of the surface of the triangular prism. Make AB the seam.

- Toon ALLE verborge besonderhede.
- Toon ALLE nodige konstruksies. **[36]**

- Show ALL hidden detail.
- Show ALL necessary construction. **[36]**

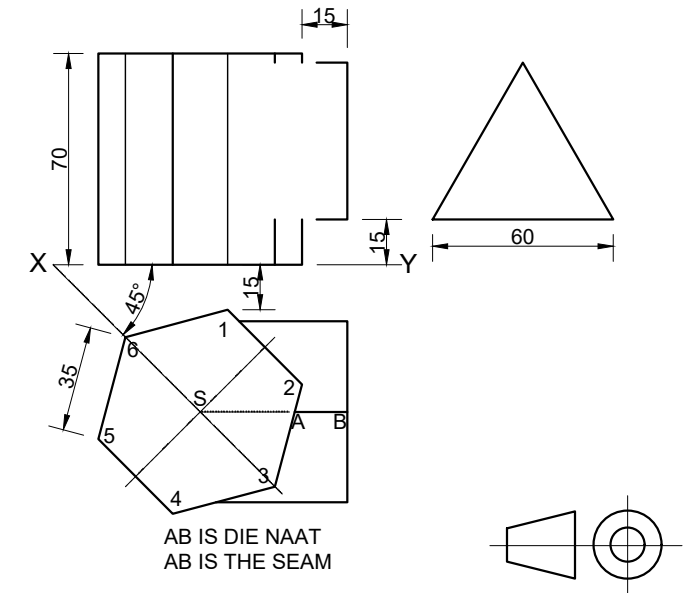

ASSESSERINGSKRITERIA ASSESSMENT CRITERIA			E	M
1	BO-AANSIG TOP VIEW (10/2)	5		
2	VOORAANSIG FRONT VIEW (18/2)	9		
3	REGTERAANSIG RIGHT VIEW	13		
4	ONTWIKKELING DEVELOPMENT (18/2)	9		
5				
TOTAAL TOTAL		36		

ASSESSERINGSKRITERIA ASSESSMENT CRITERIA		E	M
1	KONSTRUKSIE + VP's CONSTRUCTION + VP's (12/2)	6	
2	MURE + DEURE WALLS + DOORS (46/2)	23	
3	DAK ROOF	6	
4	SIRKELBOOG CIRCULAR ARC	6	
TOTAAL TOTAL		41	

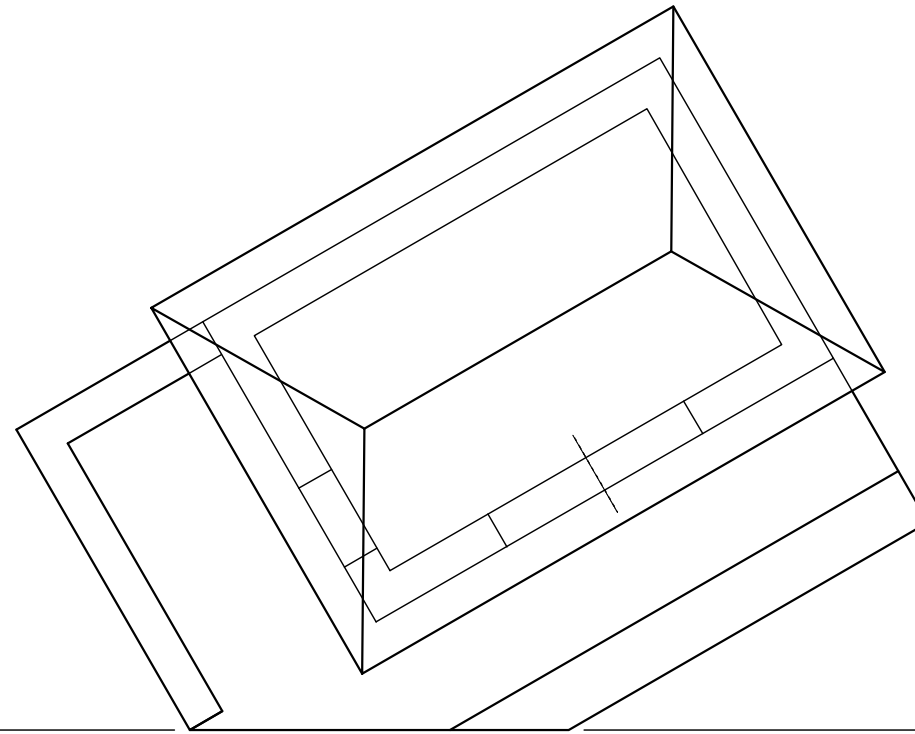

**VRAAG 3: PERSPEKTIEF**

**Gegee:**  
Drie aansigte van 'n skuiling met 'n uitkykdek en inligting benodig om 'n tweepuntperspektieftekening te teken

PV - Prentvlak  
HL - Horisonlyn  
GL - Grondlyn  
SP - Staanpunt

**Instruksies:**  
Voltooi die perspektieftekening.

- Rig die tekenvel volgens die grondlyn(GL).
- Bepaal en benoem die verdwynpunte.
- Toon ALLE nodige konstruksies.
- GEEN verborge besonderhede word verlang nie. **[41]**

**QUESTION 3: PERSPECTIVE**

**Given:**  
Three views of a shelter with a viewing deck and information needed to draw a two-point perspective drawing

PP - Picture plane  
HL - Horizon line  
GL - Ground line  
SP - Station point

**Instructions:**  
Complete the perspective drawing.

- Align the drawing sheet with the ground line (GL).
- Determine and label the vanishing points.
- Show ALL necessary construction.
- NO hidden detail is required. **[41]**

PV

PP

HL

HL

GL

GL

SP

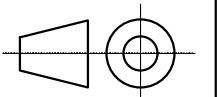



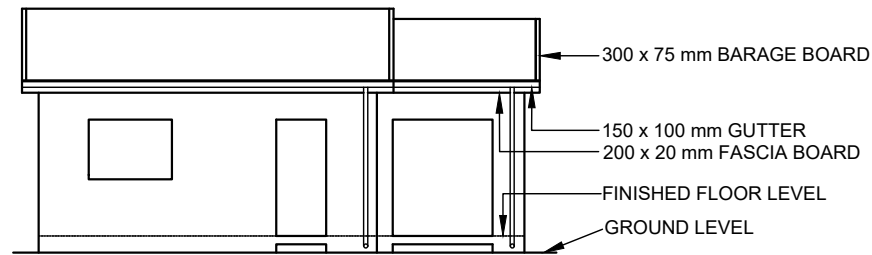

INCOMPLETE SOUTH ELEVATION

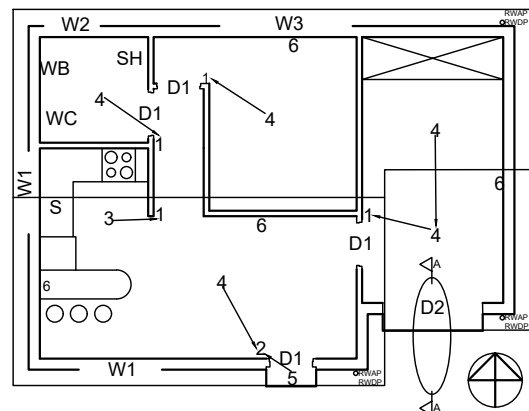

INCOMPLETE FLOOR PLAN

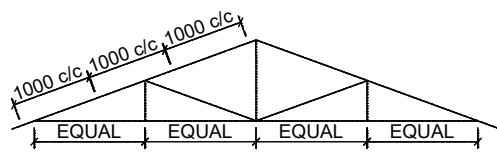

SCHEMATIC DIAGRAM OF ROOF TRUSS FOR THE MAIN BEDROOM

ROOF NOTES:  
ROOF PITCH 20°

115 x 38 mm ROOF TRUSSES ON  
115 x 38 mm WALL PLATES

ROOF OVERHANG 300 mm TO END OF  
TRUSSES

ROOF COVER 40mm IBR SHEETING ON  
75 x 50 mm PURLINS @ 1000 mm c/c

220 x 20 mm FASCIA BOARDS ON ALL  
SIDES AND 300 x 75 mm BARGE BOARD  
ON GABLE ENDS

100 x 150 mm GUTTERS ON ALL SIDES

9 mm CEILING BOARDS ON 38 x 38 mm  
BRANDERING STRIPS @ 300 mm c/c

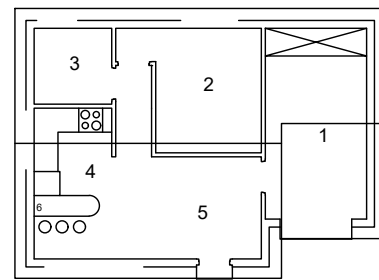
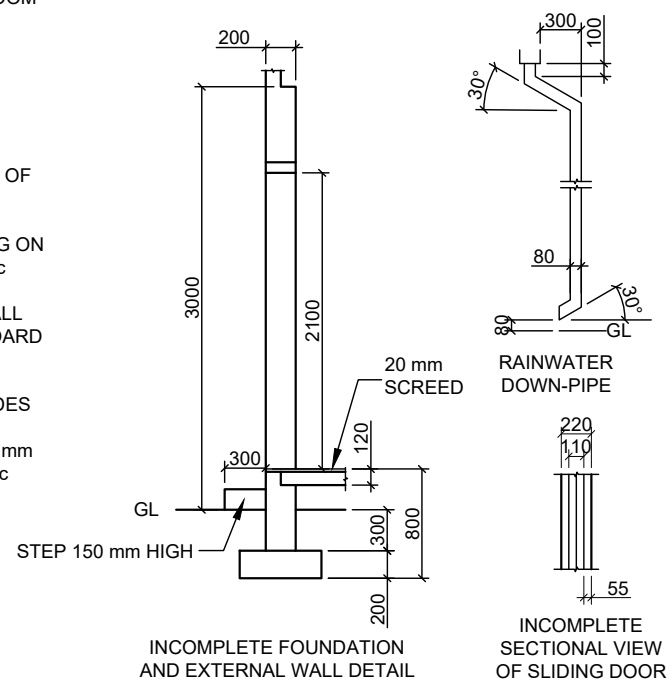

ROOM DESIGNATIONS

FLOOR FINISHES

- |                        |        |
|------------------------|--------|
| 1 MAIN BEDROOM:        | CARPET |
| 2 SECOND BEDROOM       | CARPET |
| 3 BATHROOM:            | TILE   |
| 4 KITCHEN:             | TILE   |
| 5 LOUNGE/DINNING ROOM: | WOOD   |

FEATURES

- D1 DOOR  
D2 SLIDING DOOR  
W1 WINDOW  
W2 WINDOW  
W3 WINDOW

FIXTURES

- WC TOILET  
WB WASH BASIN  
SH SHOWER  
S SINK

ELECTRICAL FITTINGS

1. ONE-WAY SWITCH - SINGLE-POLE  
2. ONE-WAY SWITCH - DOUBLE-POLE  
3. FLUORESCENT LIGHT 2 x 40 W  
4. CEILING LIGHT  
5. WALL-MOUNTED LIGHT  
6. SWITCHED SOCKET OUTLET

NOTE:  
THE ARROW SHOWS THE LIGHT  
CONNECTION TO THE SWITCH

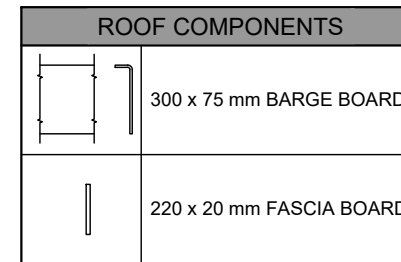

ROOF COMPONENTS

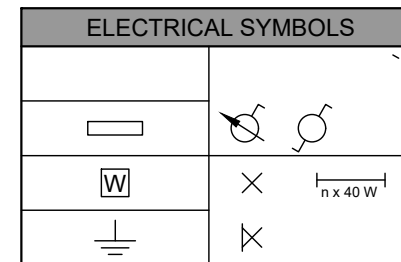

DOOR AND WINDOW SCHEDULE

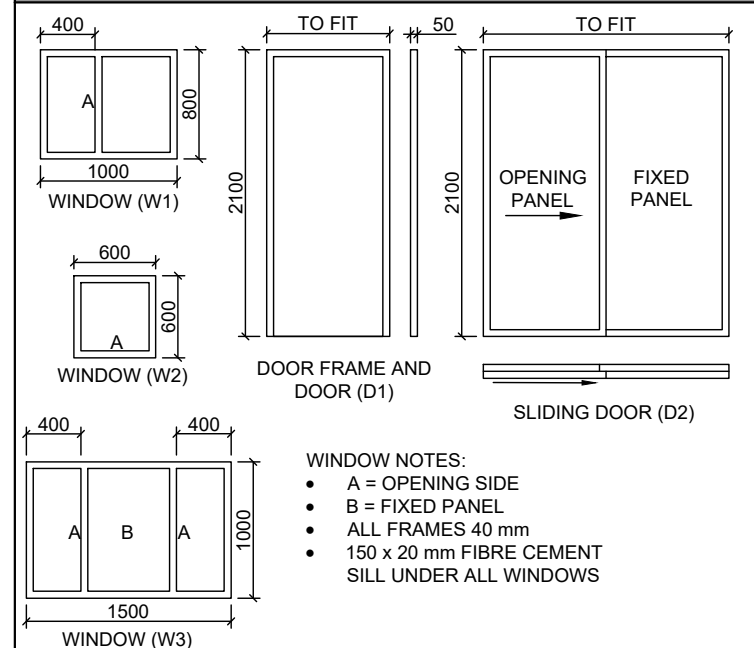

WINDOW NOTES:

- A = OPENING SIDE
- B = FIXED PANEL
- ALL FRAMES 40 mm
- 150 x 20 mm FIBRE CEMENT SILL UNDER ALL WINDOWS

FIXTURES

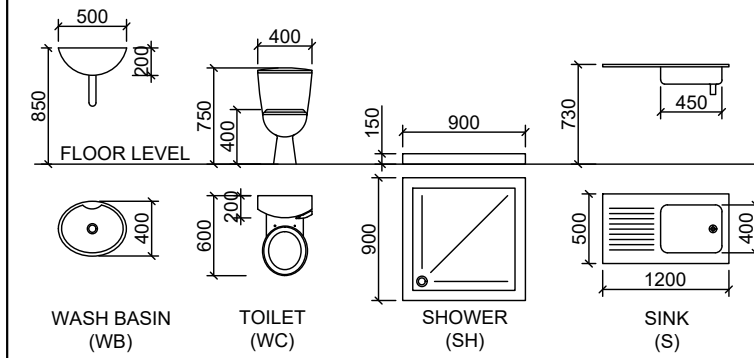

QUESTION 4: CIVIL DRAWING

Given:

- The incomplete south elevation of a new house, showing the walls, the door, windows, the roof and notes
- The incomplete floor plan showing the walls, positions of the doors, windows, fixtures and electrical layout
- A schematic diagram of a roof truss and roof notes
- The incomplete foundation and external wall details of the house
- Room designation and floor finishes
- The rainwater down-pipe
- A table of roof components
- A table of electrical symbols
- A door and window schedule
- A table of fixtures
- The incomplete floor plan of the new house, drawn to scale 1 : 50, and the incomplete foundation and the break line of the detailed section, drawn to scale 1 : 20, on page 6

Instructions:

Answer the question on page 6.

4.1 Using the incomplete floor plan, draw, in first-angle orthographic projection and to scale 1 : 50, the following views of the new house:

4.1.1 THE COMPLETE FLOOR PLAN

Add the following features to the drawing:

- ALL doors and windows
- ALL fixtures as indicated by the abbreviations
- ALL electrical fittings as indicated by the numbers
- ALL hatching detail

4.1.2 THE COMPLETE SOUTH ELEVATION

Show the following features on the drawing:

- The outside walls, door and window details
- The roof detail, including the fascia boards, barge boards, gutters and rainwater down-pipes
- The finished floor level

4.2 Using the incomplete foundation and break line on page 6, draw, to scale 1 : 20, a DETAILED SECTION on cutting plane A-A of the area in the ellipse shown on the incomplete floor plan.

Show the following features on the drawing:

- The foundation and wall detail
- The roof detail, including the fascia board and gutters
- ALL the external features of the new house to the left (west) of the ellipse
- ALL hatching detail. ONLY the substructure hatching may be drawn in neat freehand.

Label the following:

- The room designations and floor finishes
- Ground level and damp-proof course (use the correct abbreviation and show it on ALL the relevant views)

NOTE:

ALL drawings must comply with the guidelines and graphical symbols contained in the SANS 10143. [94]

SUIDAANSIG / SOUTH ELEVATION  
SKAAL 1 : 50 / SCALE 1 : 50

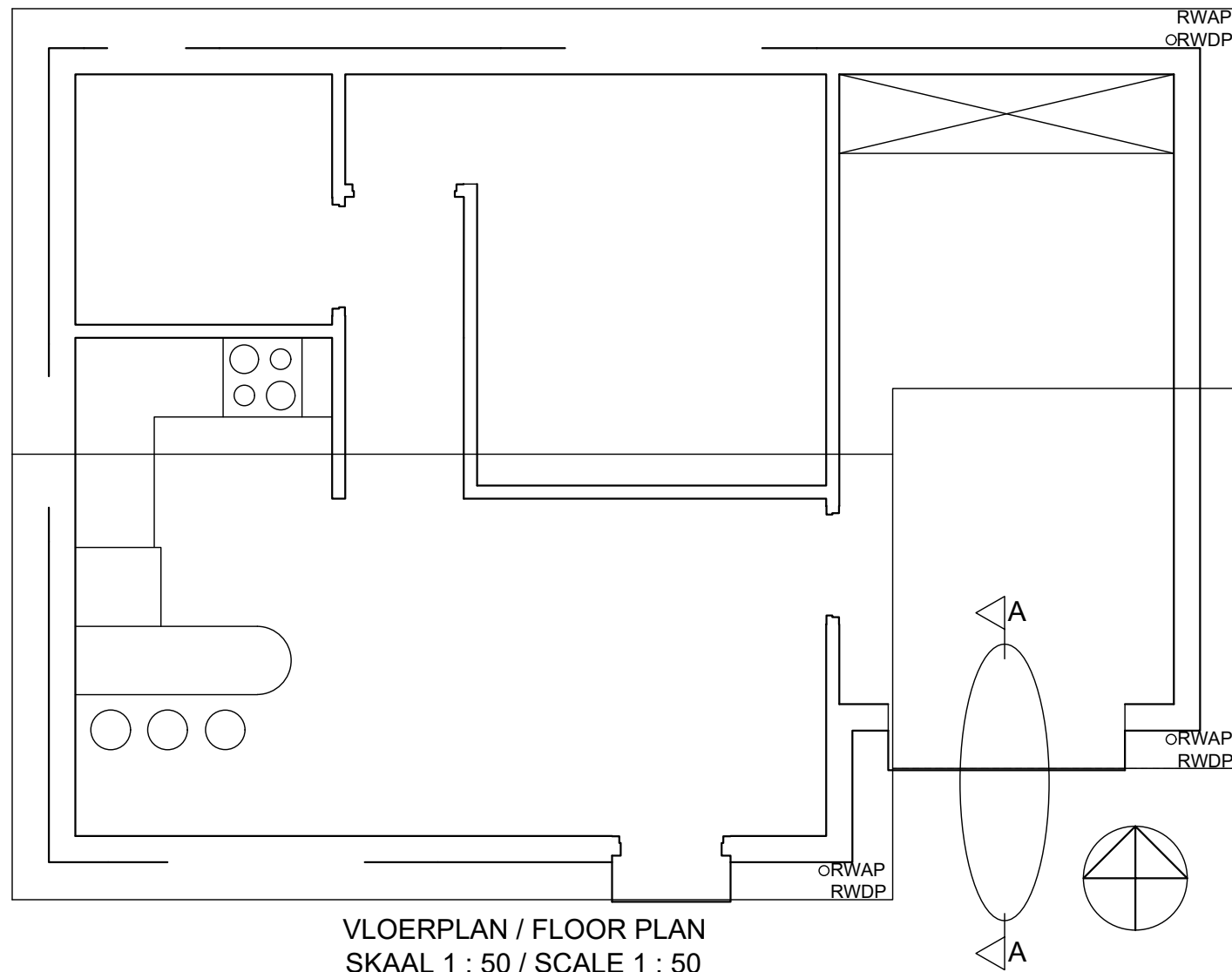

SECTION A-A  
SCALE 1 : 20

ASSESSERINGSKRITERIA ASSESSMENT CRITERIA					
VLOERPLAN FLOOR PLAN				E	M
1	VENSTERS + DEURE WINDOW + DOORS	23/2=	11½		
2	ELEKTRIESE TOEBEHORE ELECTRICAL FIXTURES	23/2=	11½		
3	TOEBEHORE FIXTURES	16/2=	8		
4	ARSERING HATCHING	4/2=	2		
5	BYSKRIFTE LABELS	10/2=	5		
SUB-TOTAAL SUB TOTAL			38		
SUIDAANSIG SOUTH ELEVATION					
1	MUUR + RWAP + VVV + TRAPPE WALL + RWDP + FFL + STEPS	16/2=	8		
2	VENSTERS & DEUR WINDOWS & DOOR	19/2=	9½		
3	DAK ROOF	10/2=	5½		
SUB TOTAAL SUB TOTAL			23		
DEURSNEE-AANSIG SECTIONAL VIEW					
1	FONDASIE + ARSERING FOUNDATION + HATCHING	14/2=	7		
2	MUUR + DEUR + ARSERING + TRAPPE WALL + DOOR + HATCHING + STEPS	26/2=	13		
3	DAK ROOF		11		
4	BYSKRIFTE LABEL		2		
SUB-TOTAAL SUB TOTAL			33		
TOTAAL TOTAL			94		