



LOCI of a CAM

Grade 11 & 12

Developed by: PC Viljoen
Senior Educational Specialist for
Engineering Graphics and Design
Free State Province

Loci of a CAM: General information

- After the displacement graph is developed?
 - Allow for the **minimum clearance** on the cam plate

Loci of a CAM: General information

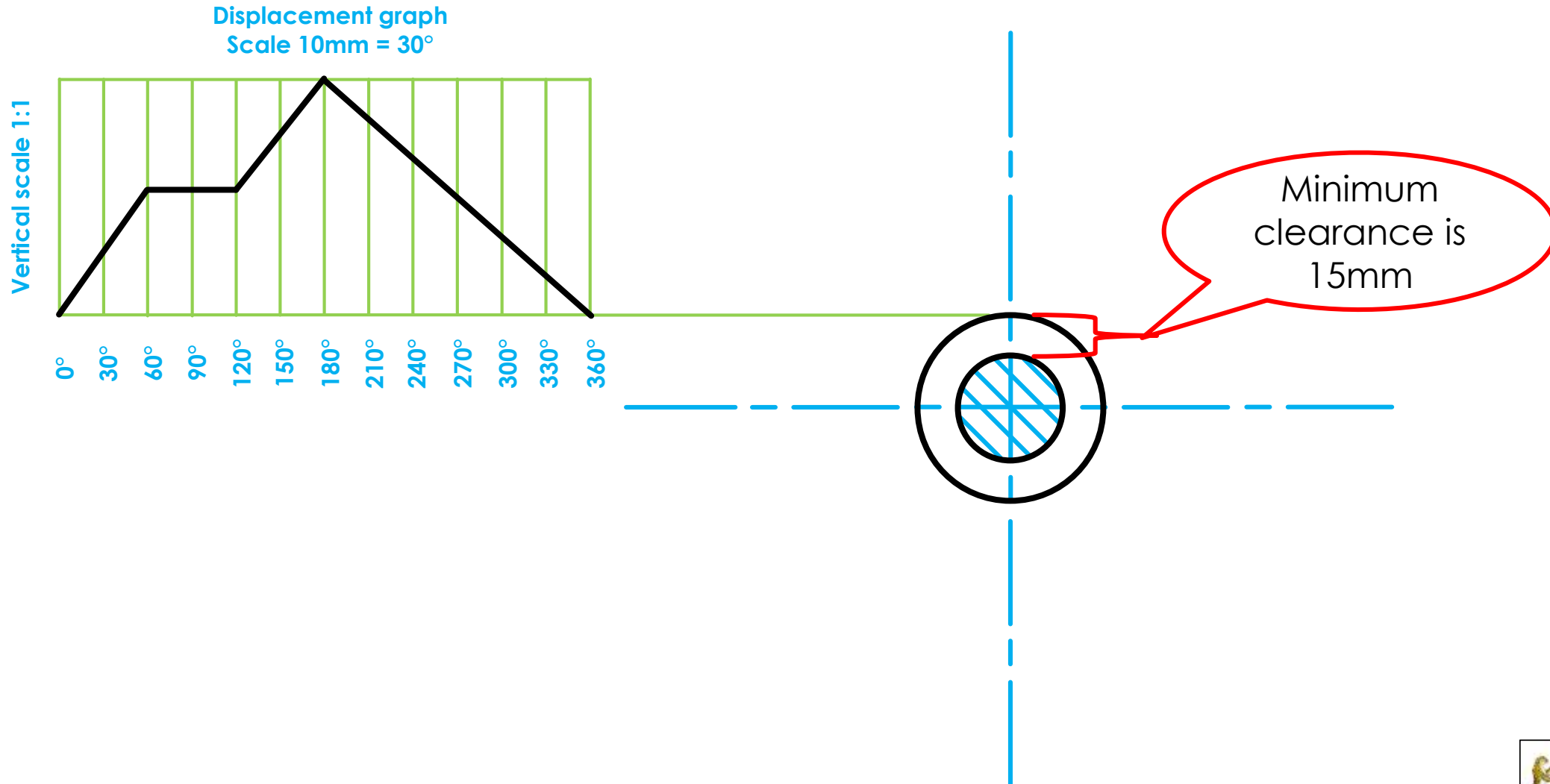

Loci of a CAM: General information

- After the displacement graph is developed?
 - Allow for the **maximum clearance** on the cam plate

Loci of a CAM: General information

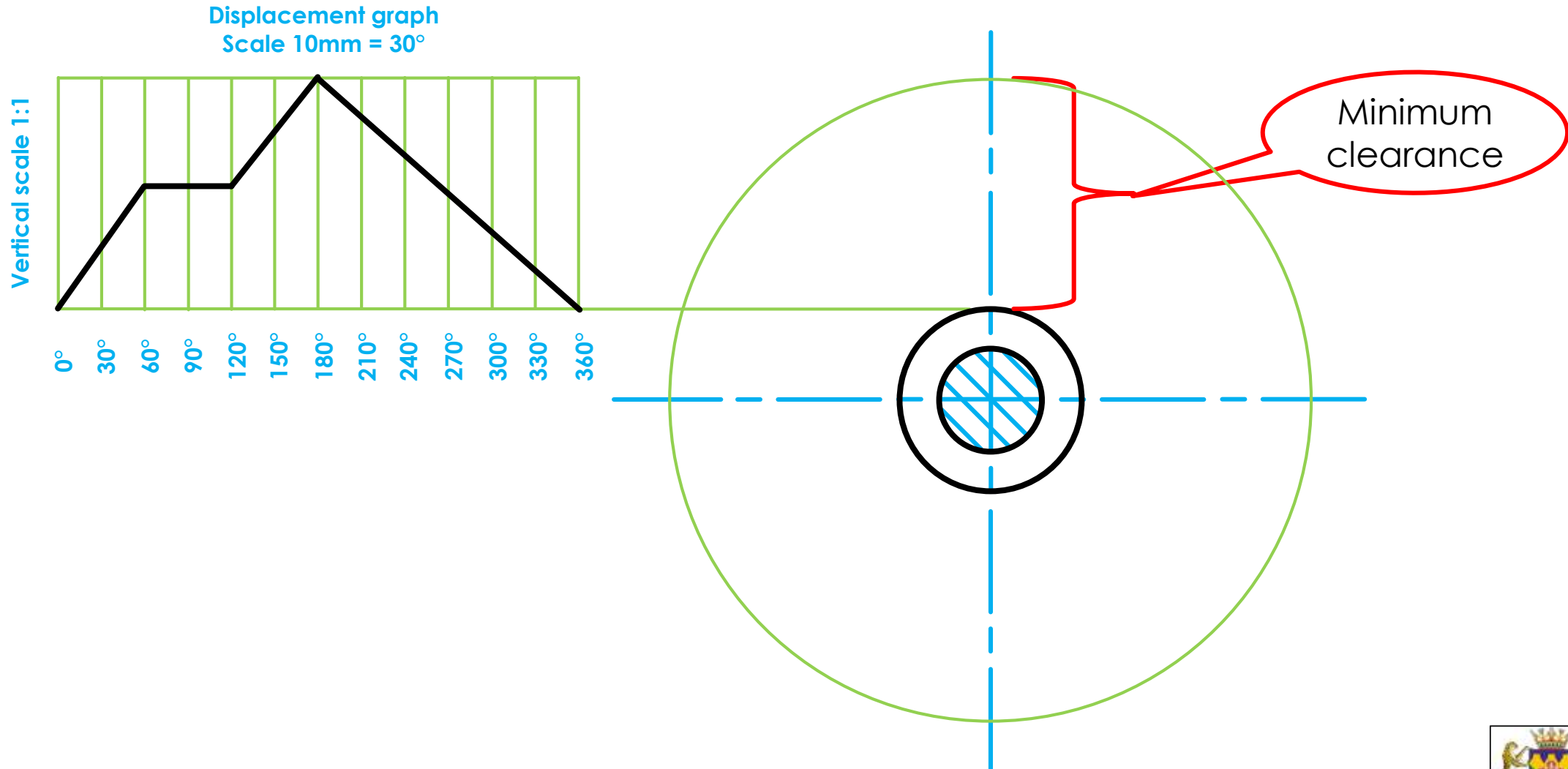

Loci of a CAM

By means of uniform motion

- 0° - 60° : Rise for 50%
- 60° - 120° : Rest
- 120° - 180° : Rise to maximum
- 180° - 360° : Back to original position

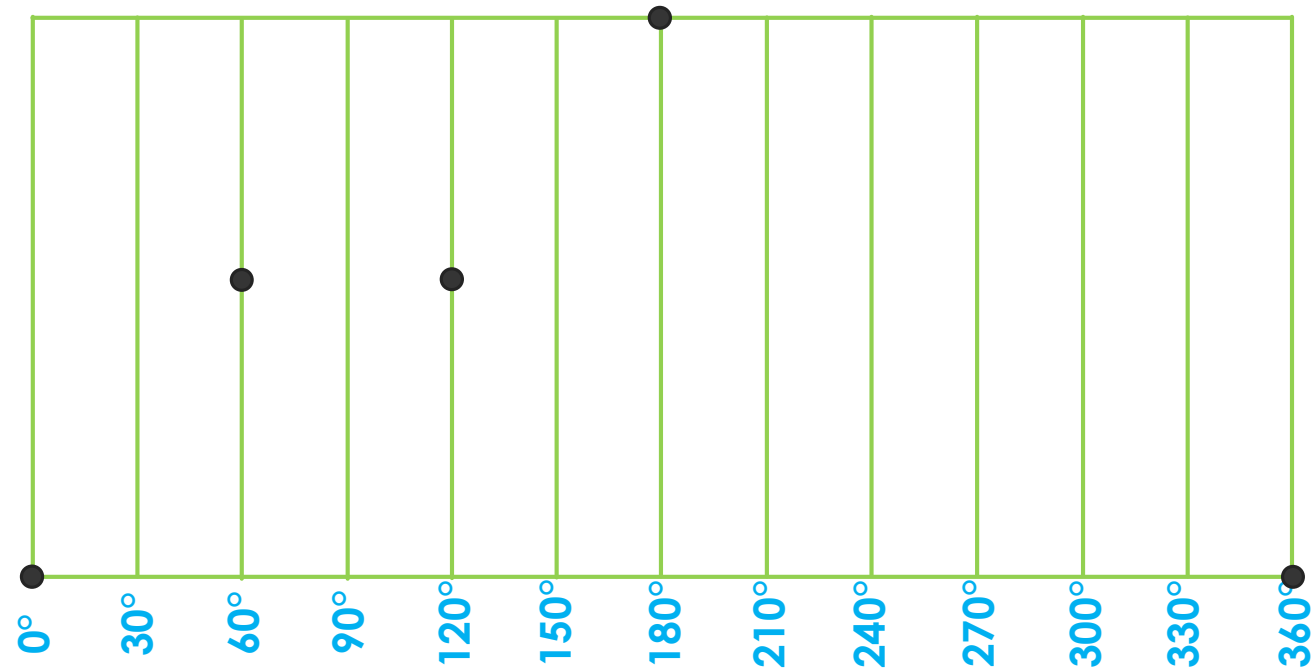

Displacement graph
Scale 10mm = 30°

Vertical scale 1:1

Loci of a CAM

By means of uniform motion

- 0° - 60° : Rise for 50%
- 60° - 120° : Rest
- 120° - 180° : Rise to maximum
- 180° - 360° : Back to original position

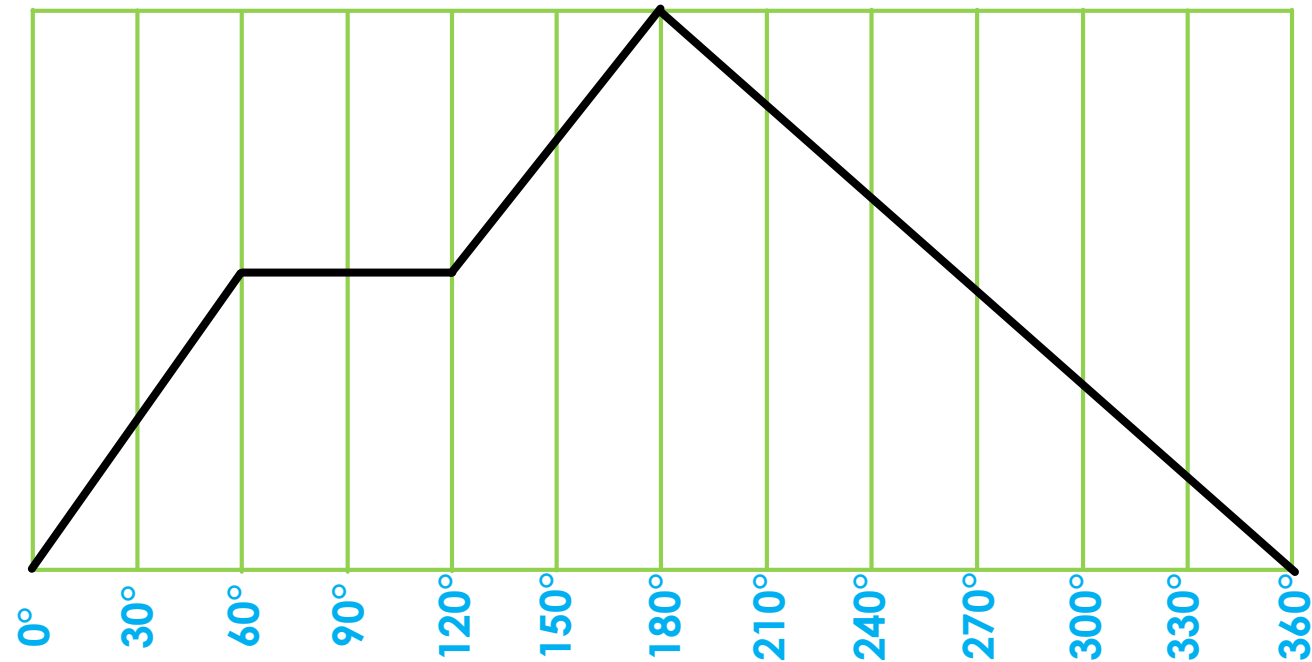

Vertical scale 1:1

Displacement graph
Scale 10mm = 30°

Loci of a CAM

- Transfer the information on the displacement graph to the cam plate once the displacement graph is developed

Loci of a CAM

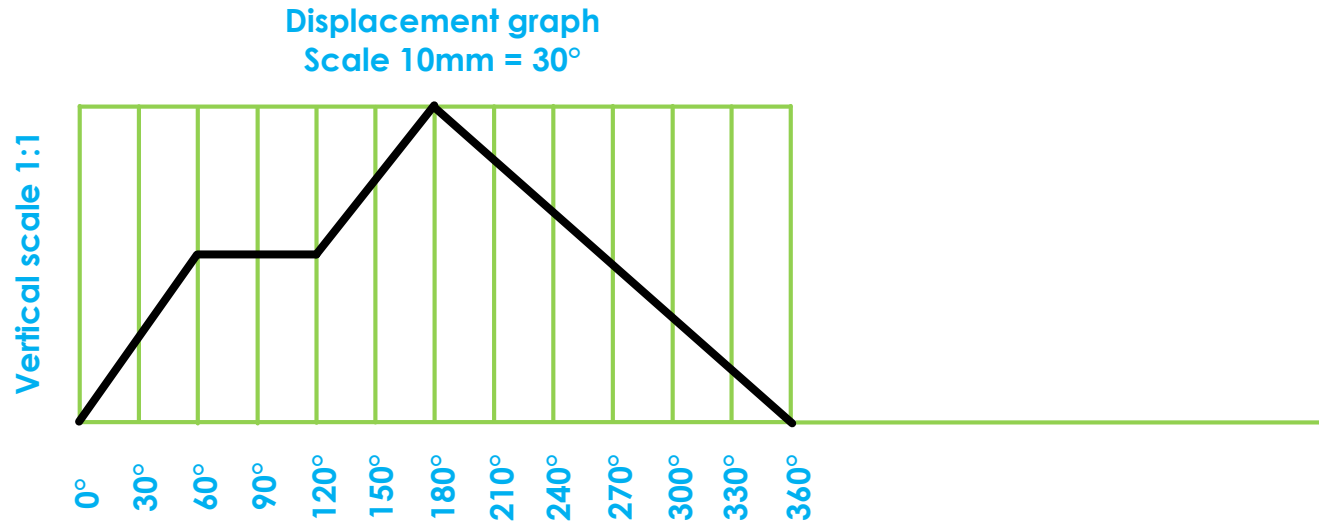

Loci of a CAM

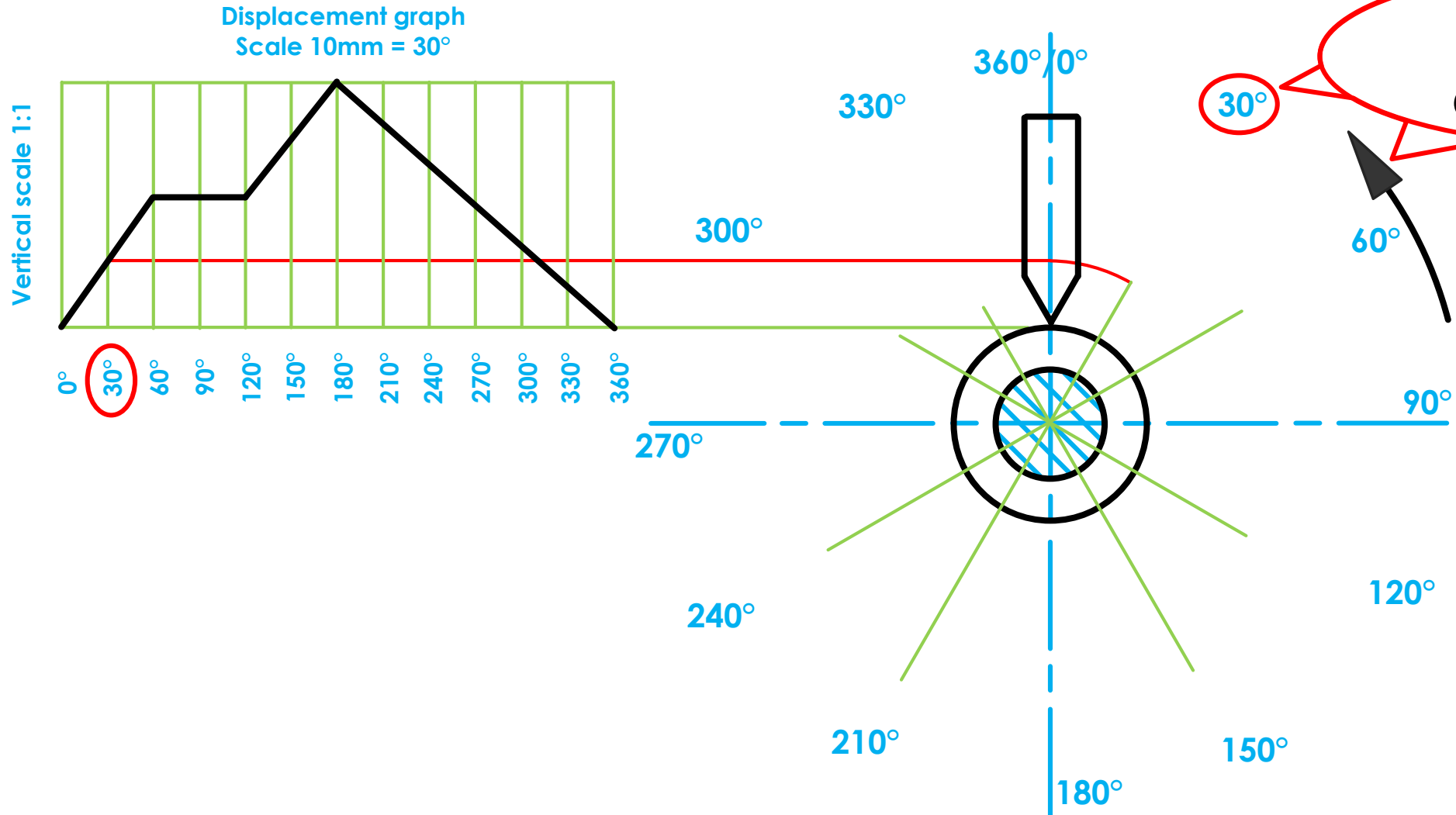

Loci of a CAM

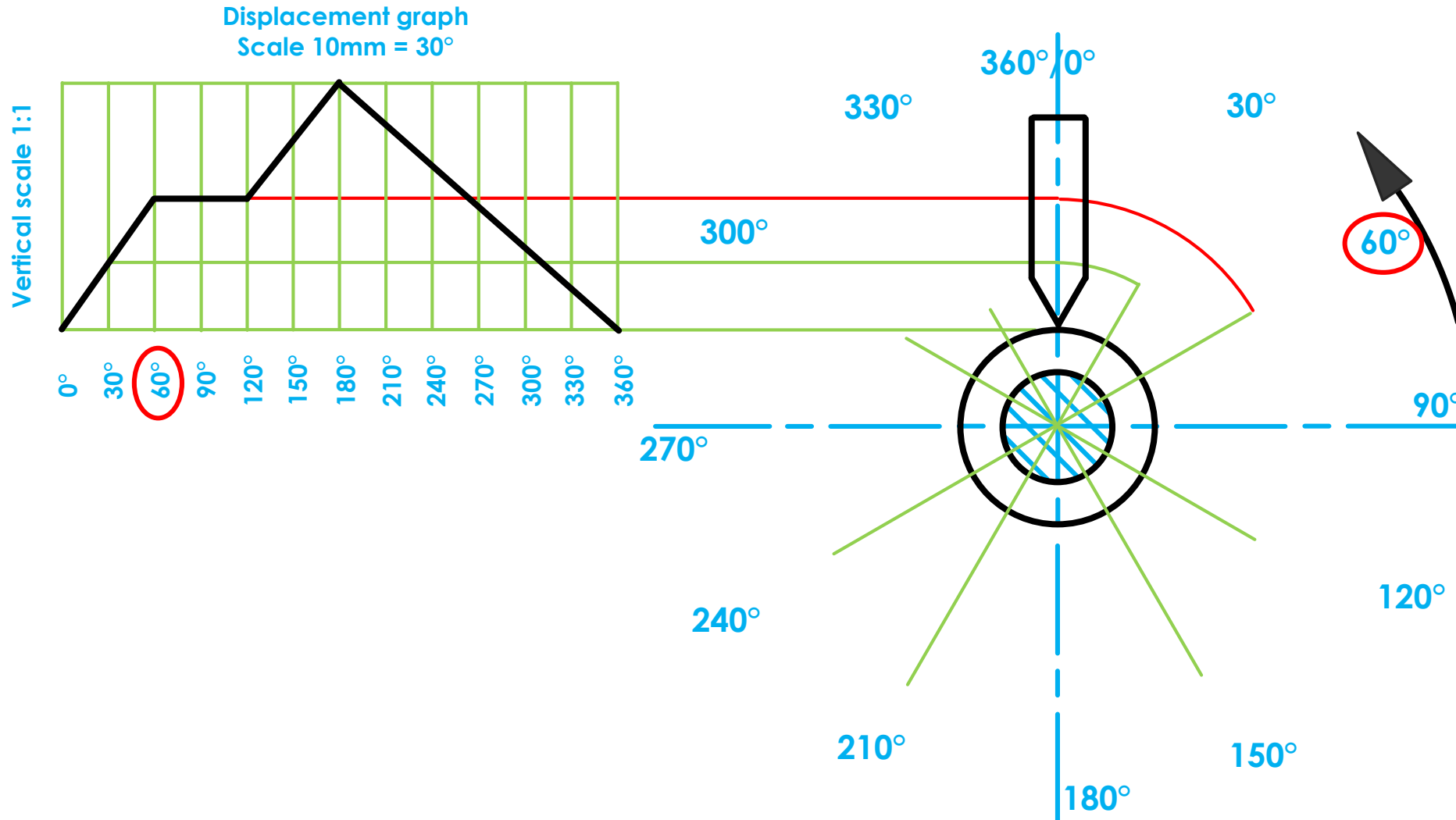

Anti-clockwise

Loci of a CAM

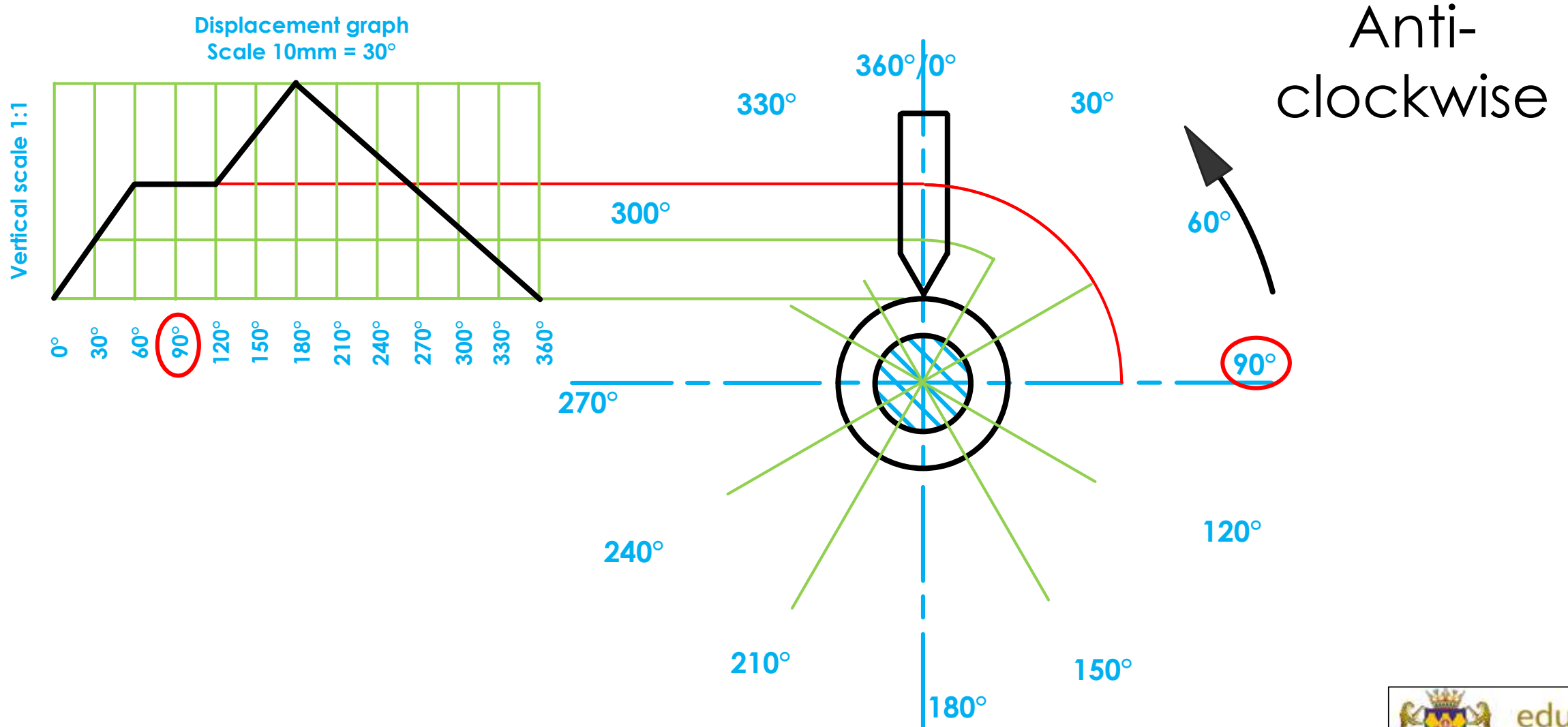

Loci of a CAM

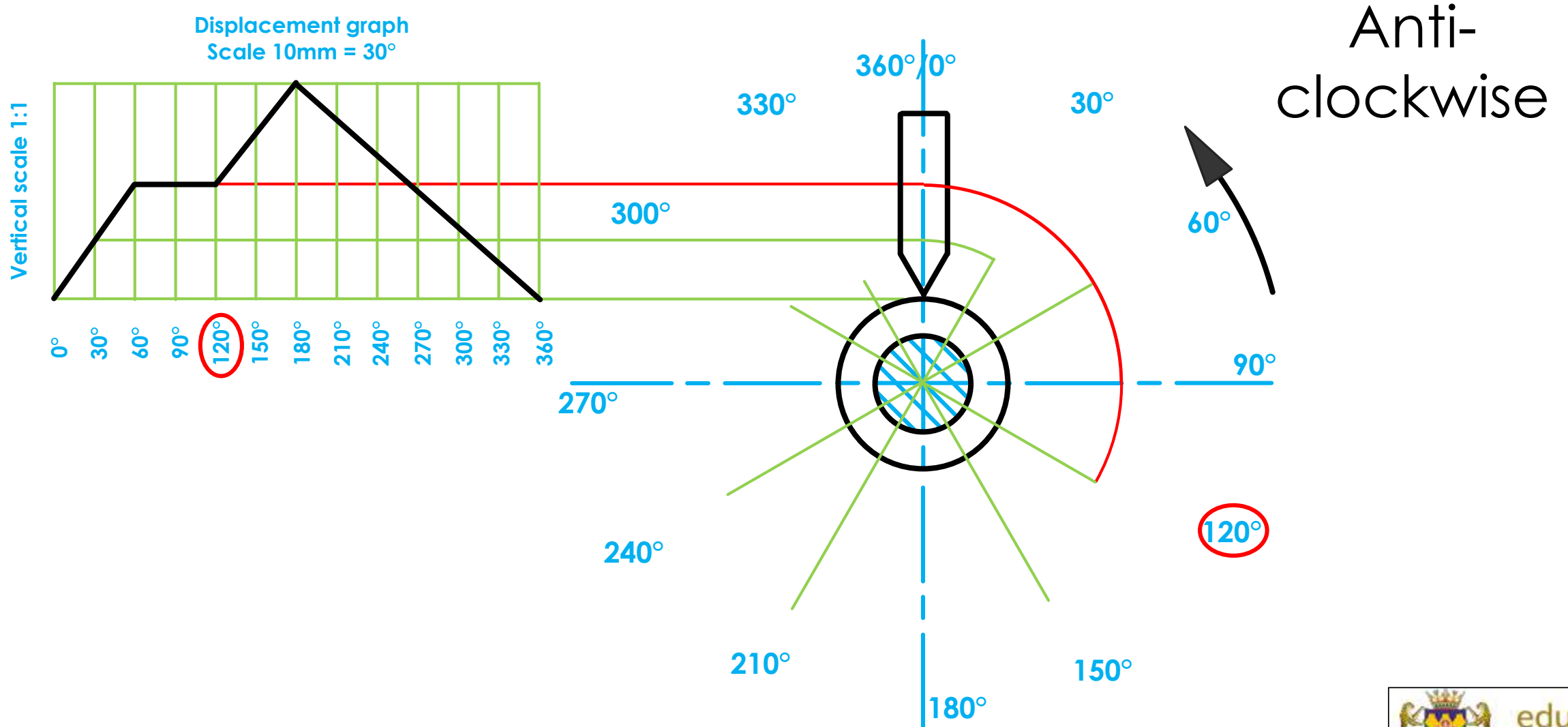

Loci of a CAM

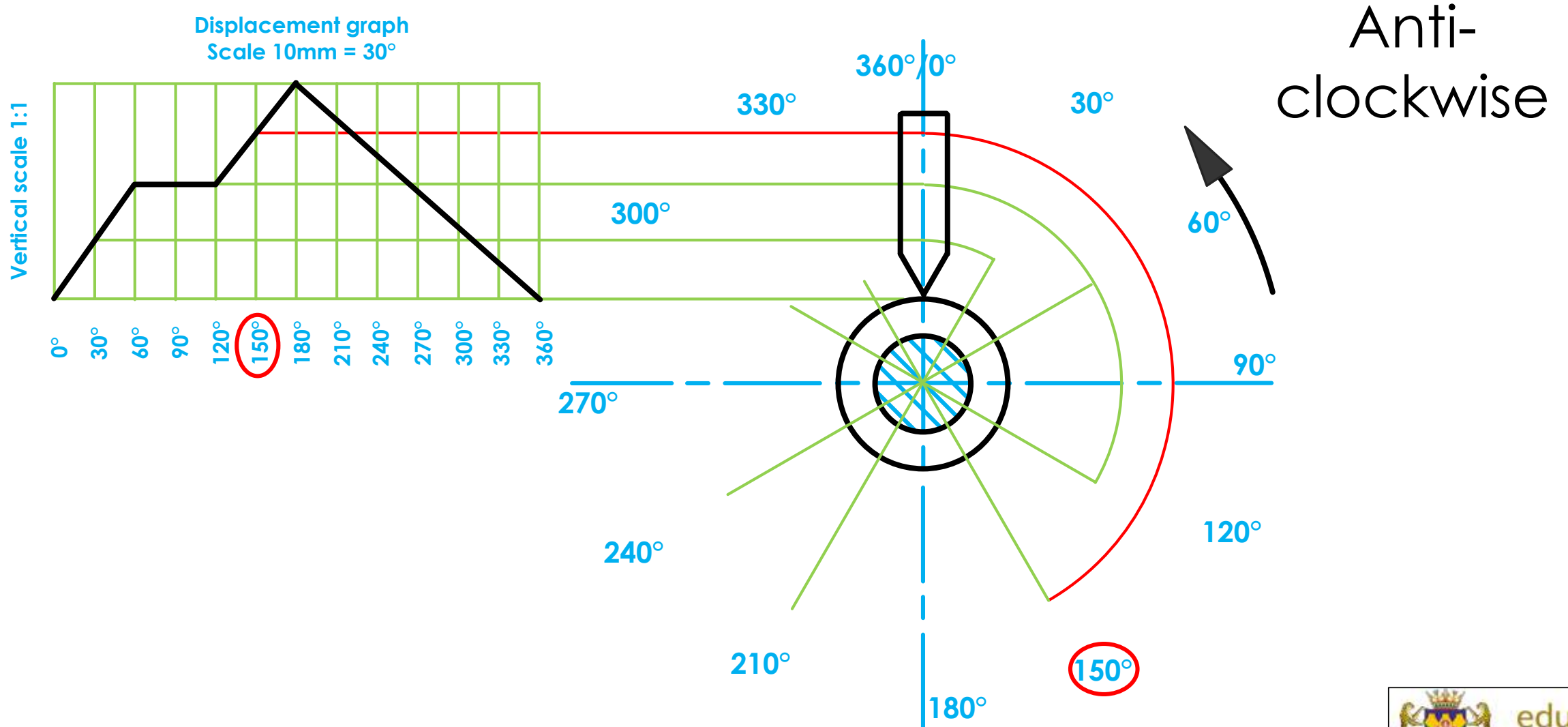

Loci of a CAM

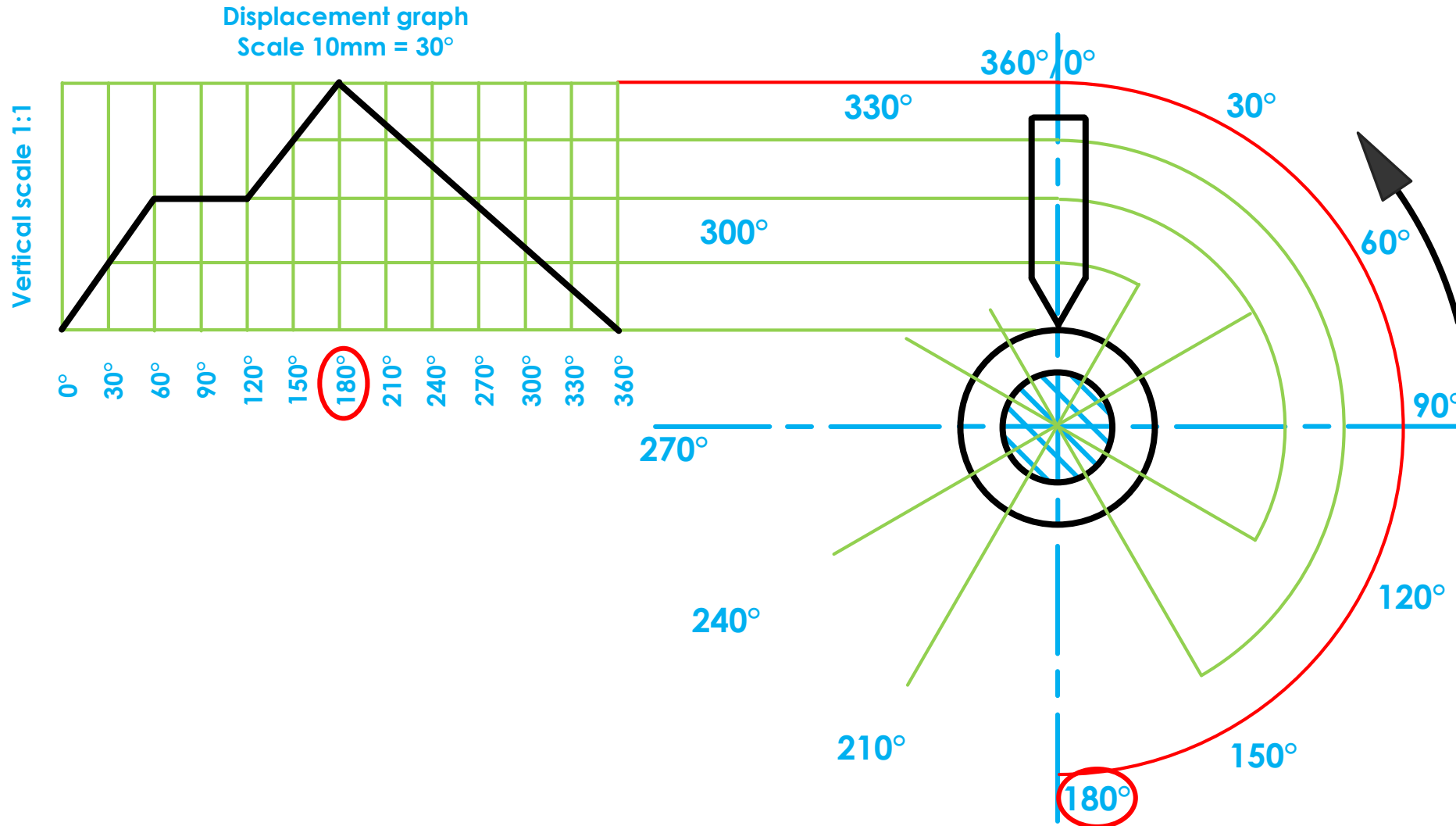

Loci of a CAM

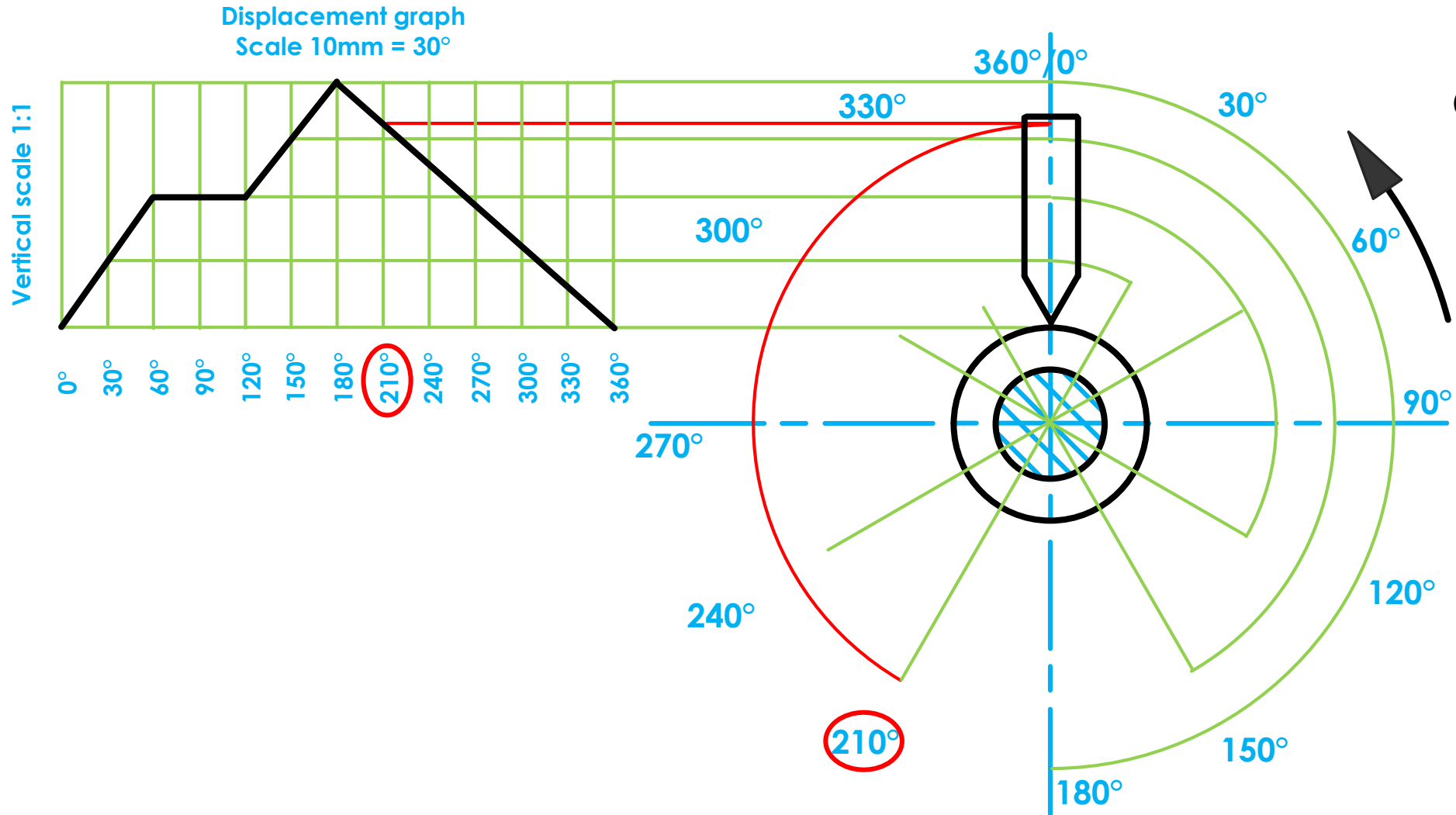

Loci of a CAM

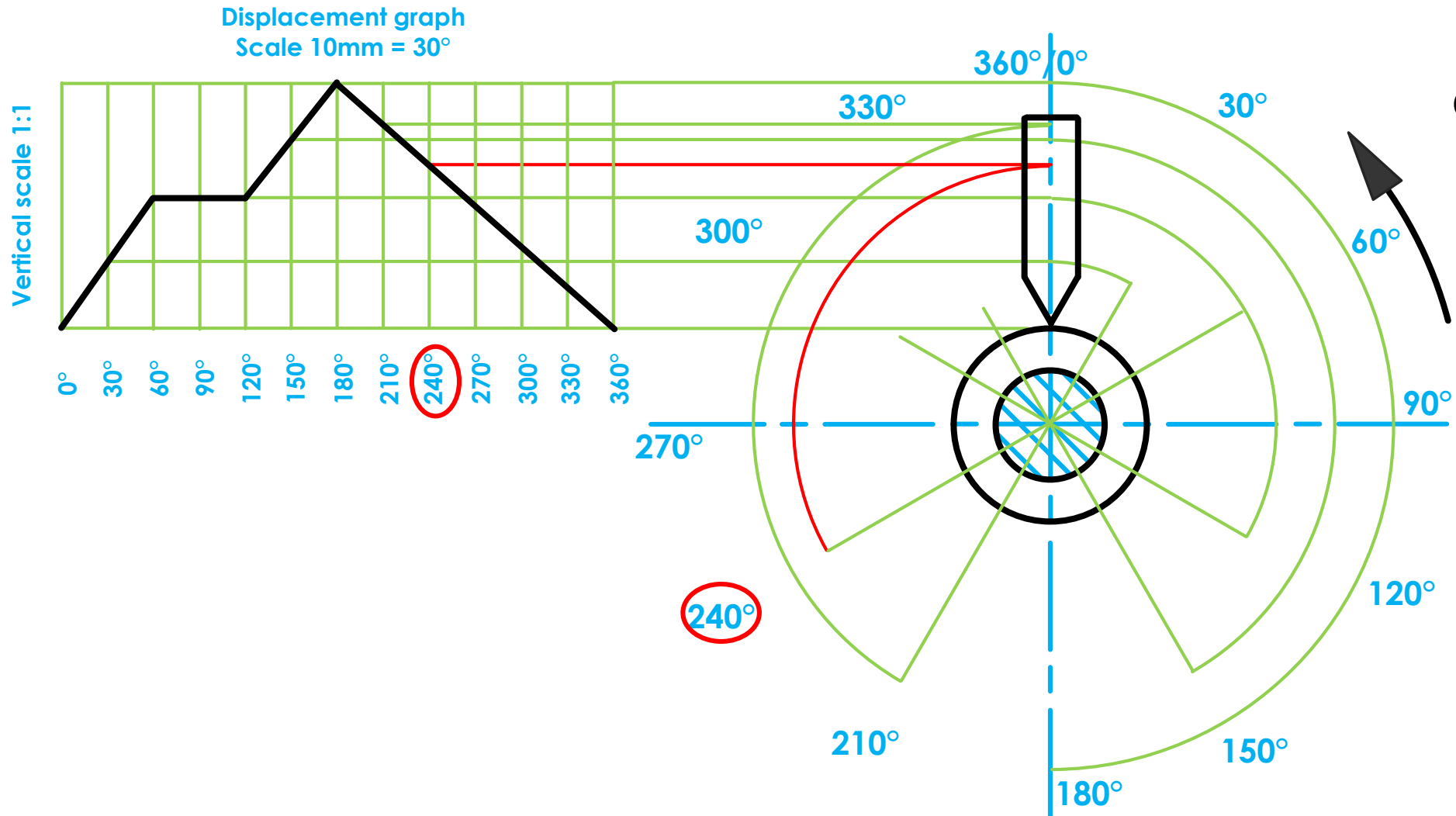

Anti-
clockwise

Loci of a CAM

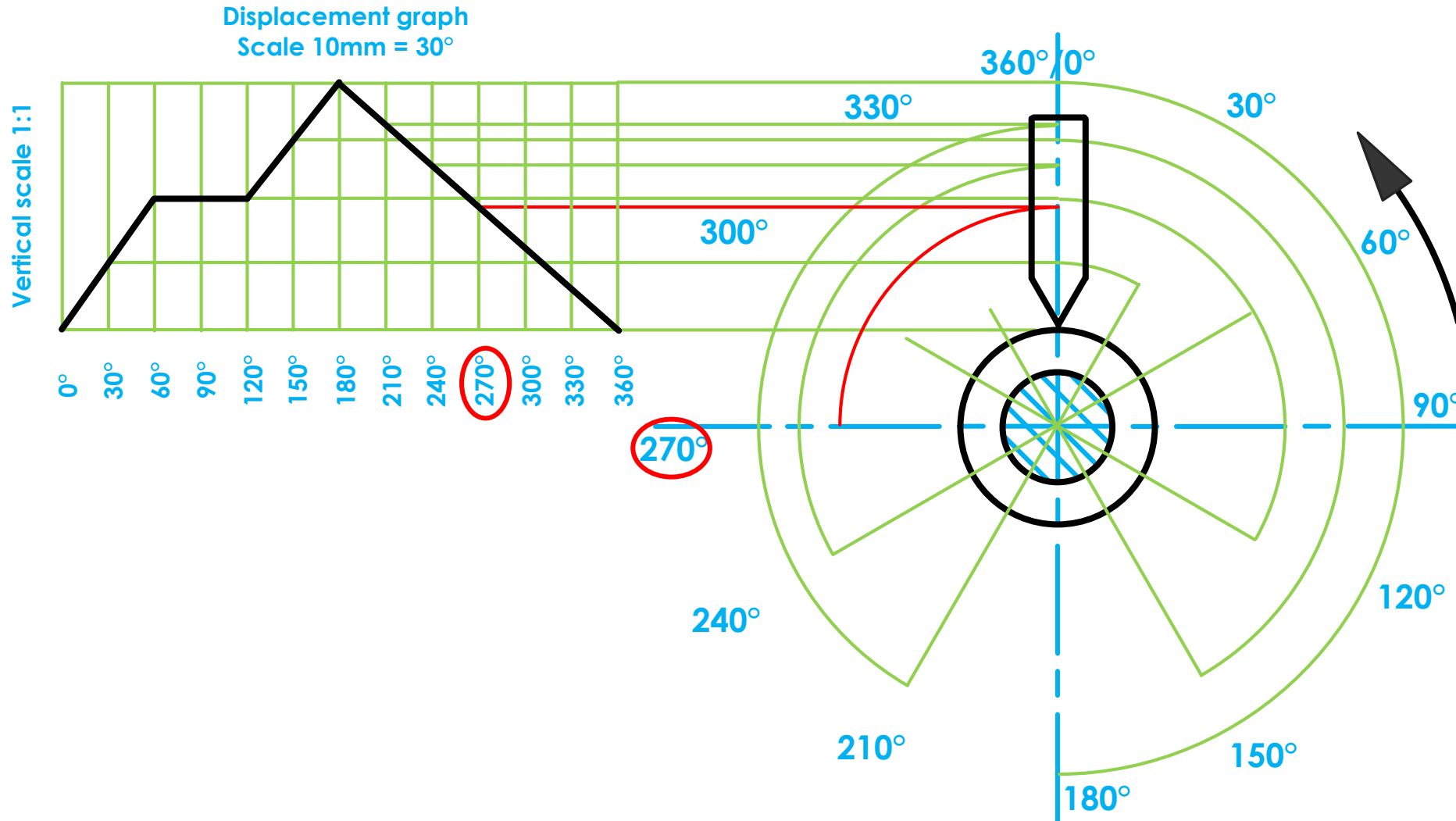

Anti-
clockwise

Loci of a CAM

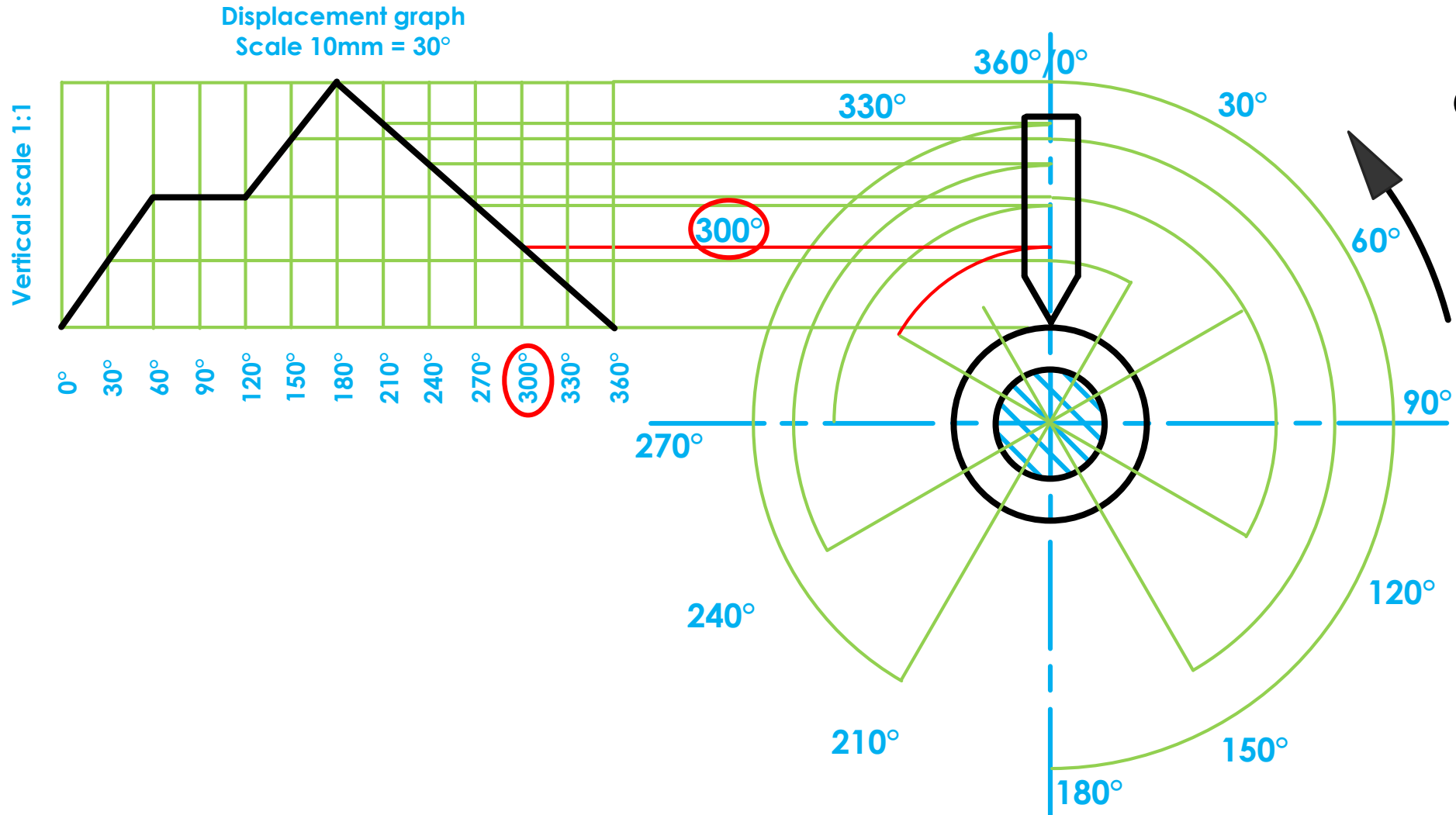

Anti-
clockwise

Loci of a CAM

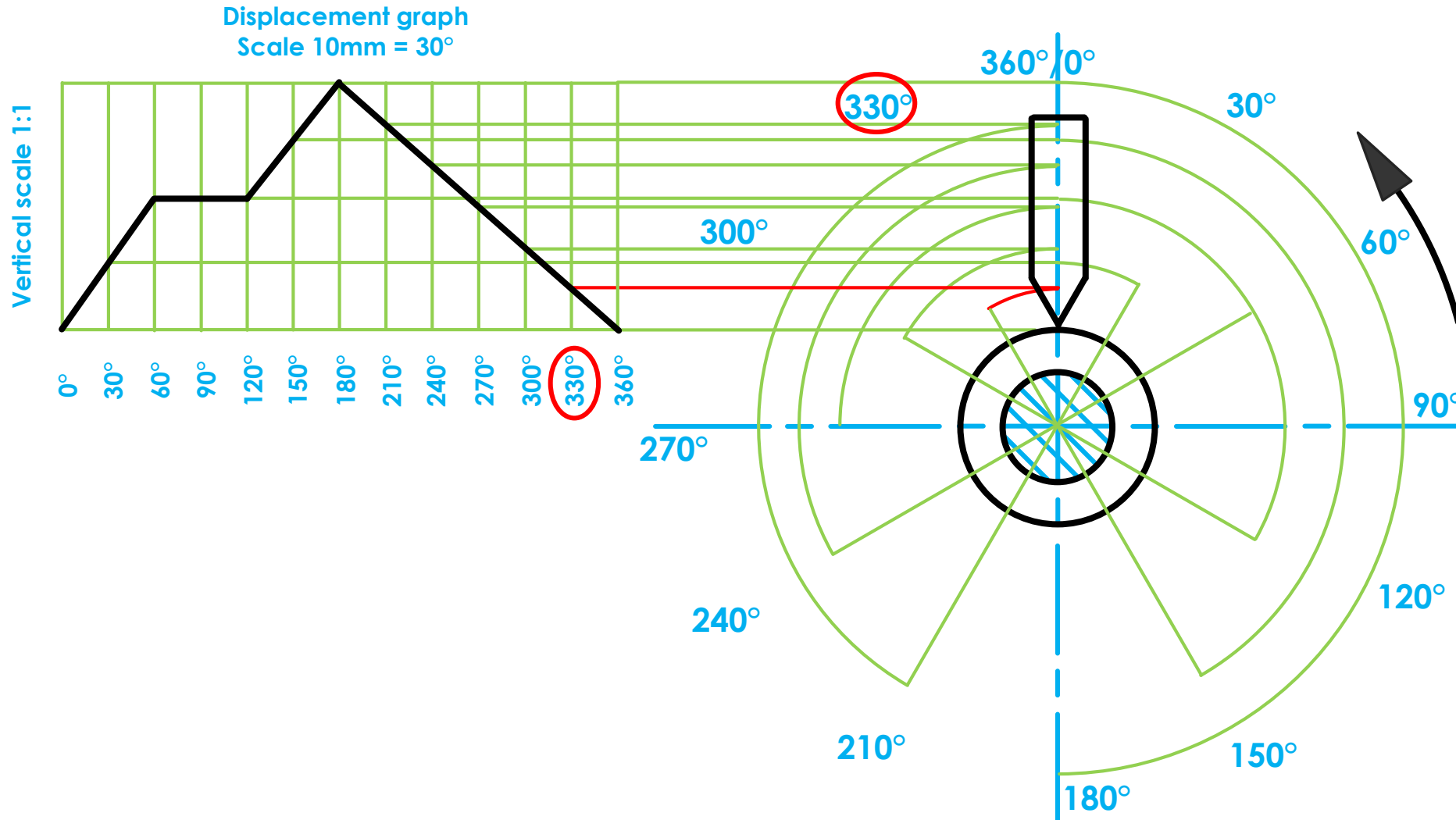

Anti-
clockwise

Loci of a CAM

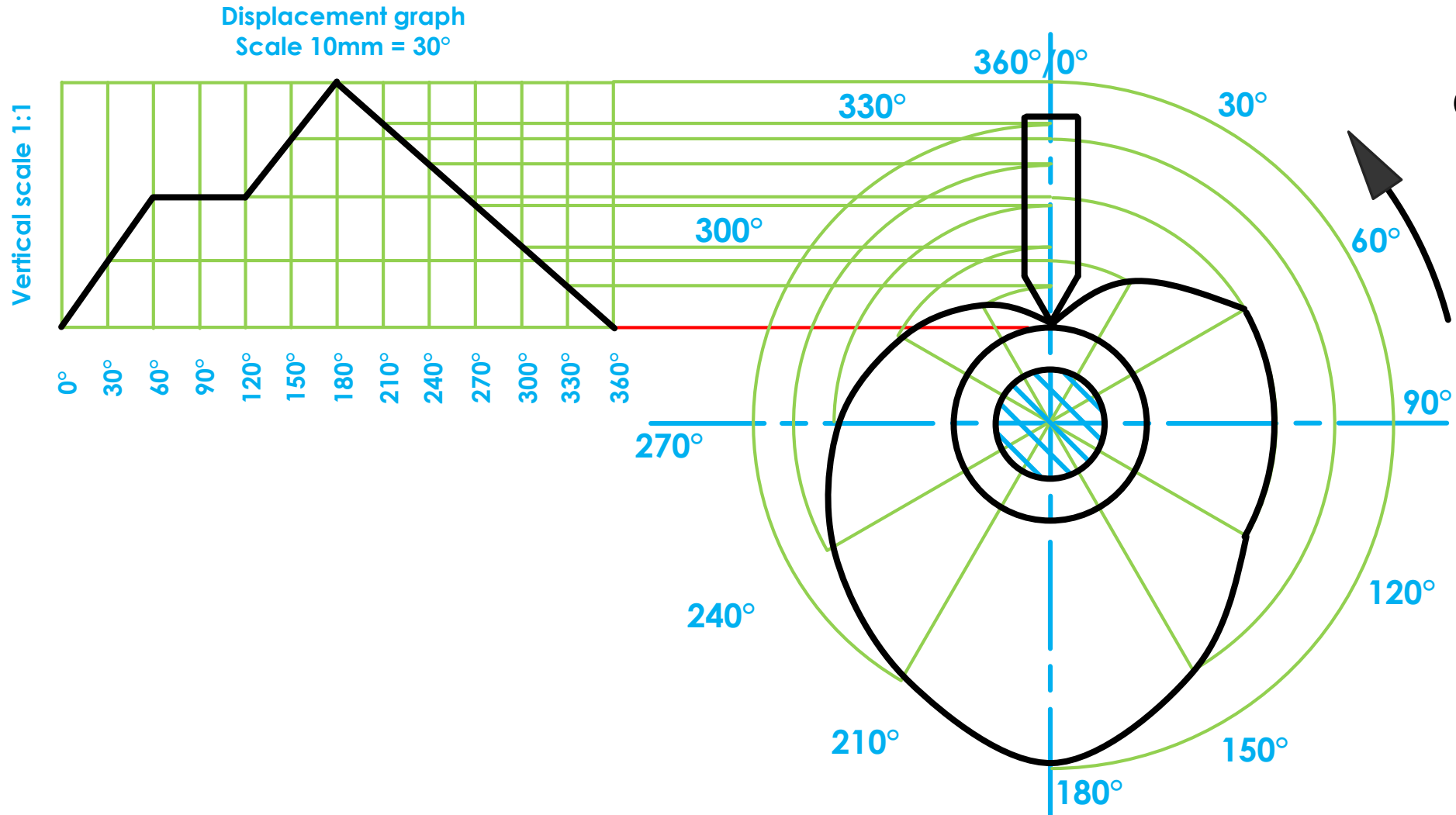

Anti-
clockwise

Loci of a CAM

Unequal number

- 0° - 210° : Rise for 50mm by means of **acceleration and retardation movement**
- 210° - 360° : Back to original position by means of **uniform motion**

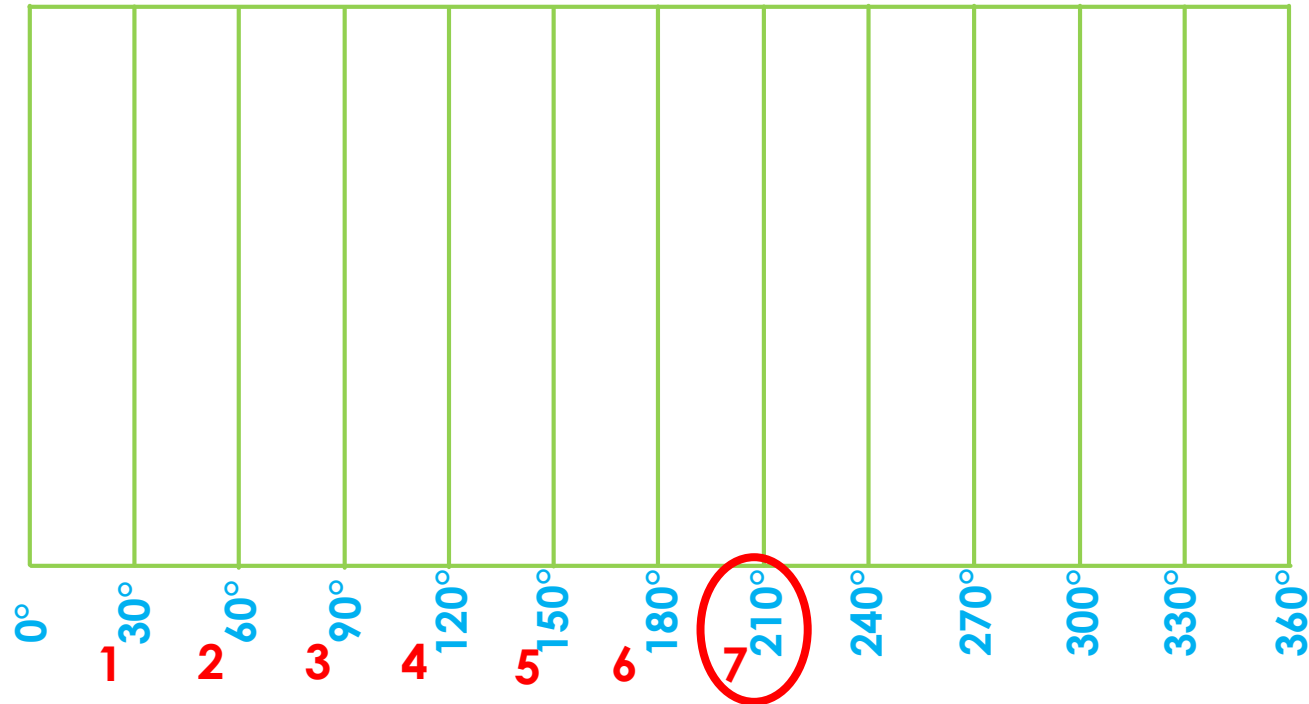

Displacement graph
Scale $10\text{mm} = 30^\circ$

Vertical scale 1:1

Loci of a CAM

Unequal number

- 0° - 210° : Rise for 50mm by means of **acceleration and retardation movement**
- 210° - 360° : Back to original position by means of **uniform motion**

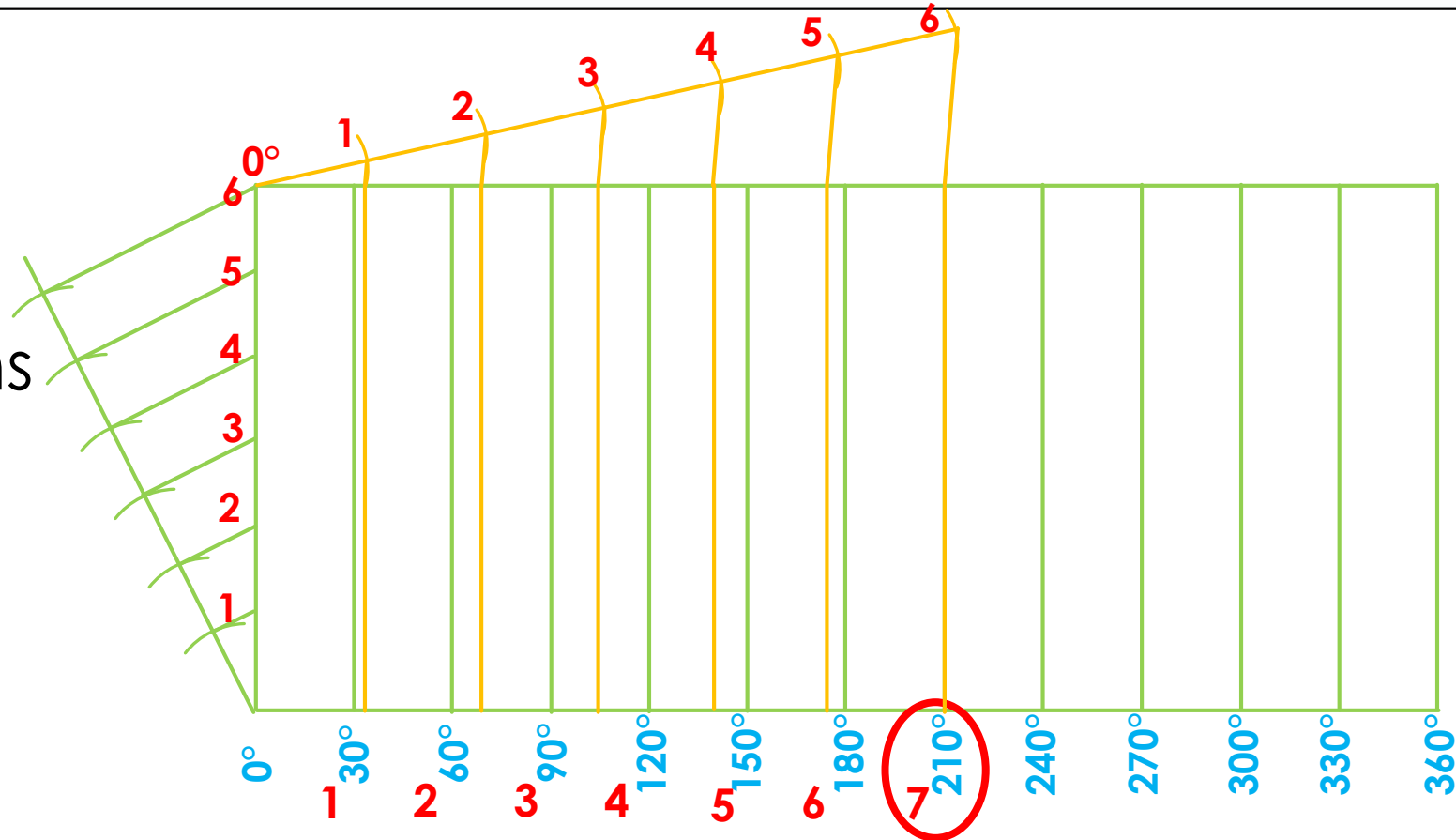

Displacement graph
Scale $10\text{mm} = 30^\circ$

Loci of a CAM

Unequal number

- 0° - 210° : Rise for 50mm by means of **acceleration and retardation movement**
- 210° - 360° : Back to original position by means of **uniform motion**

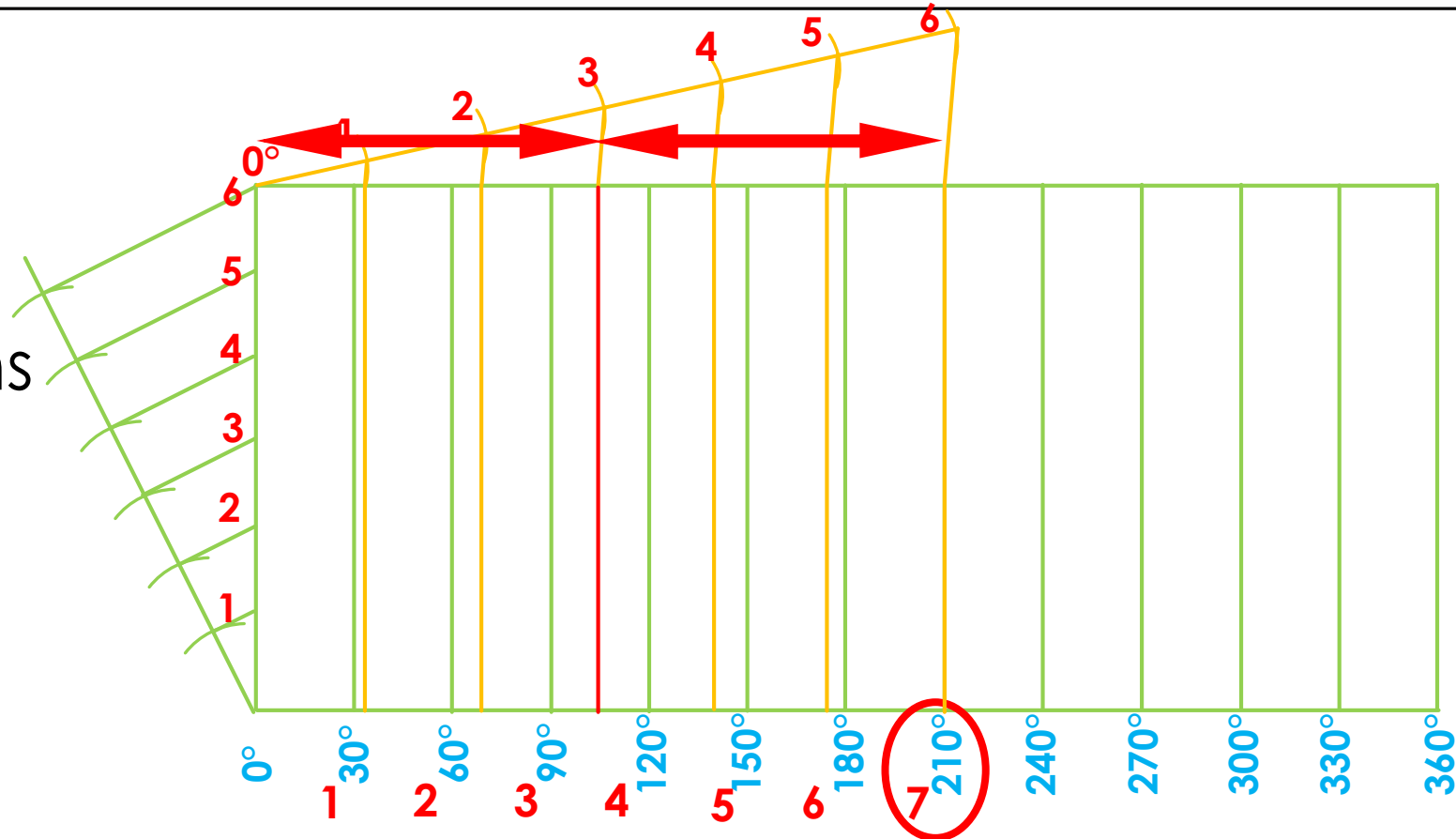

Displacement graph
Scale $10\text{mm} = 30^\circ$

Vertical scale 1:1

Loci of a CAM

Unequal number

- 0° - 210° : Rise for 50mm by means of **acceleration and retardation movement**
- 210° - 360° : Back to original position by means of **uniform motion**

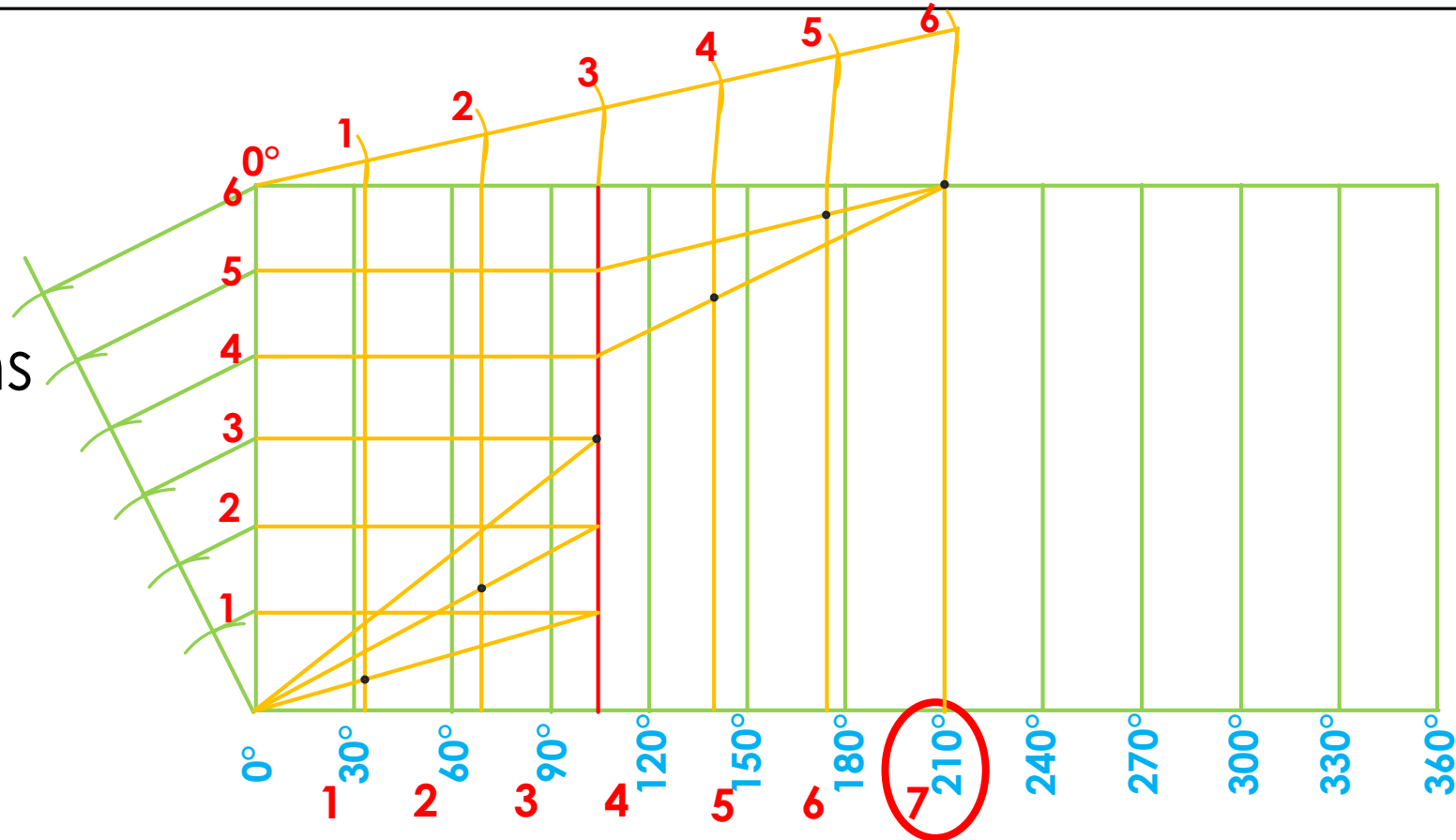

Displacement graph
Scale 10mm = 30°

Vertical scale 1:1

Loci of a CAM

Unequal number

- 0° - 210° : Rise for 50mm by means of **acceleration and retardation movement**
- 210° - 360° : Back to original position by means of **uniform motion**

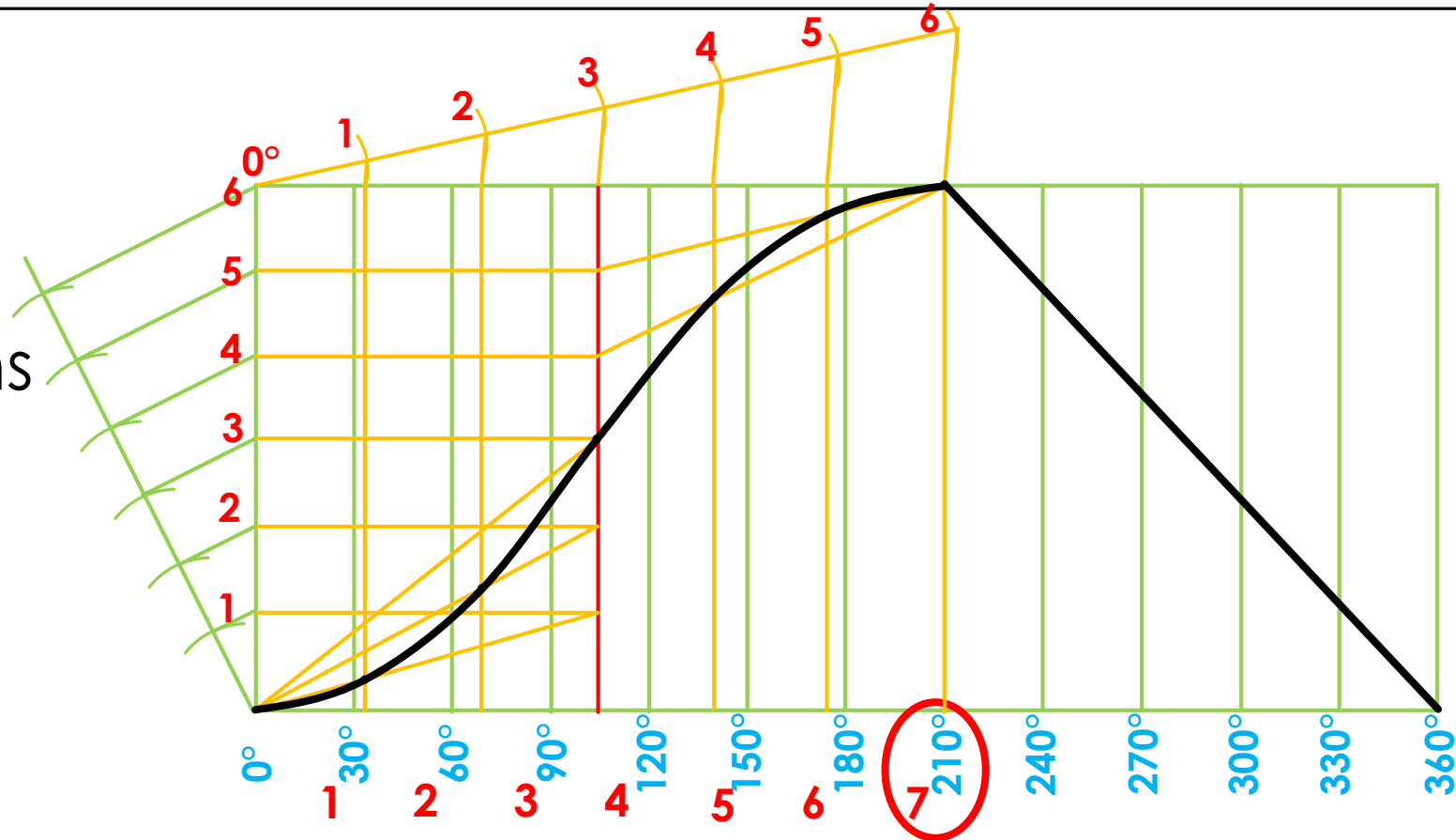

Displacement graph
Scale 10mm = 30°

Vertical scale 1:1

Loci of a CAM

- ➡ Transfer the information on the displacement graph to the cam plate once the displacement graph is developed

Loci of a CAM

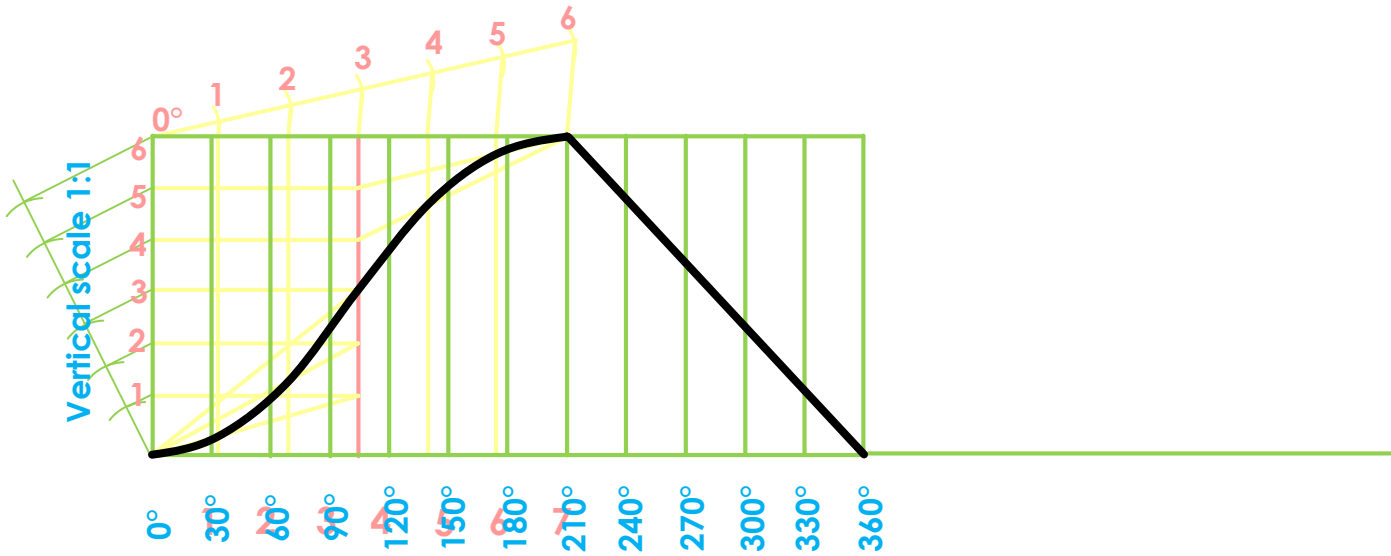

Displacement graph
Scale 10mm = 30°

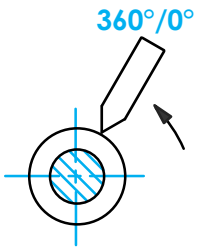

Loci of a CAM

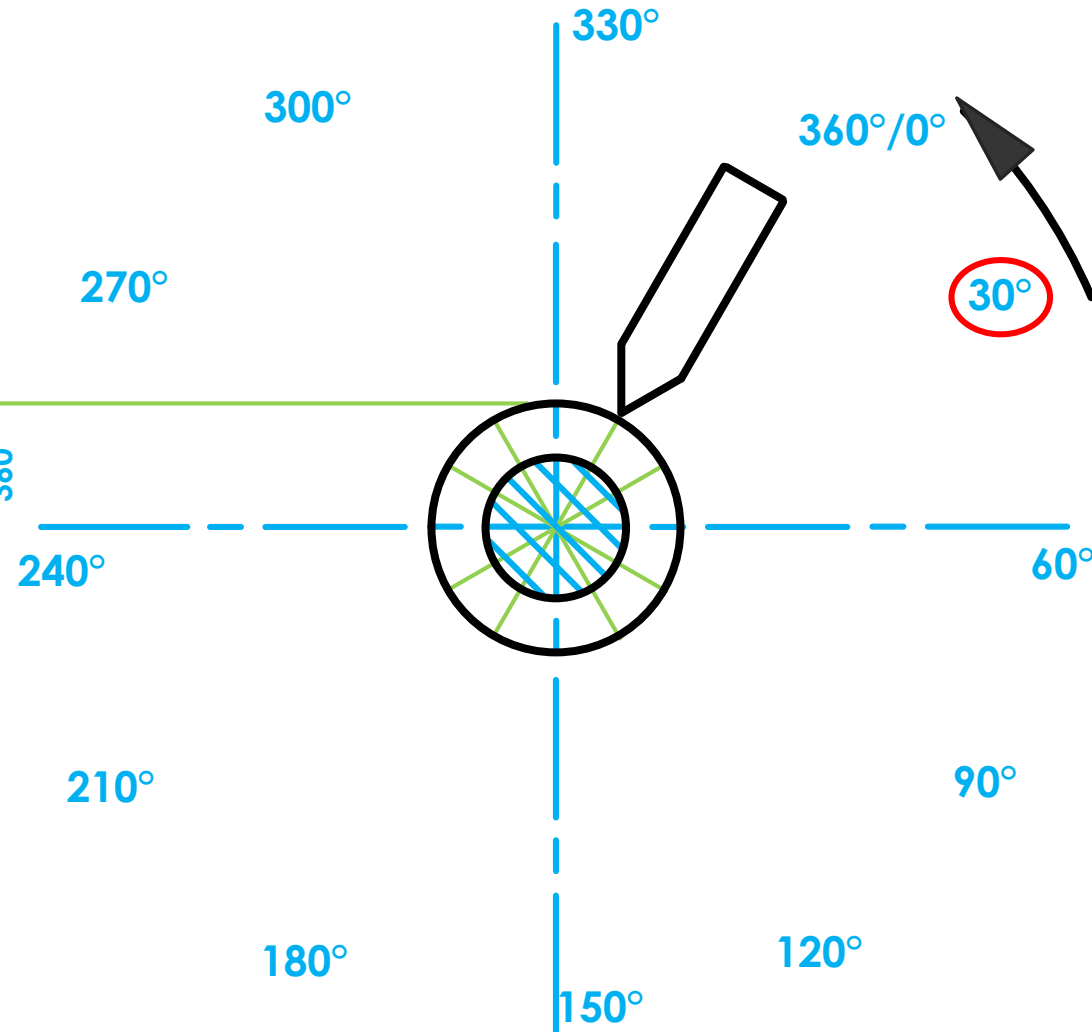
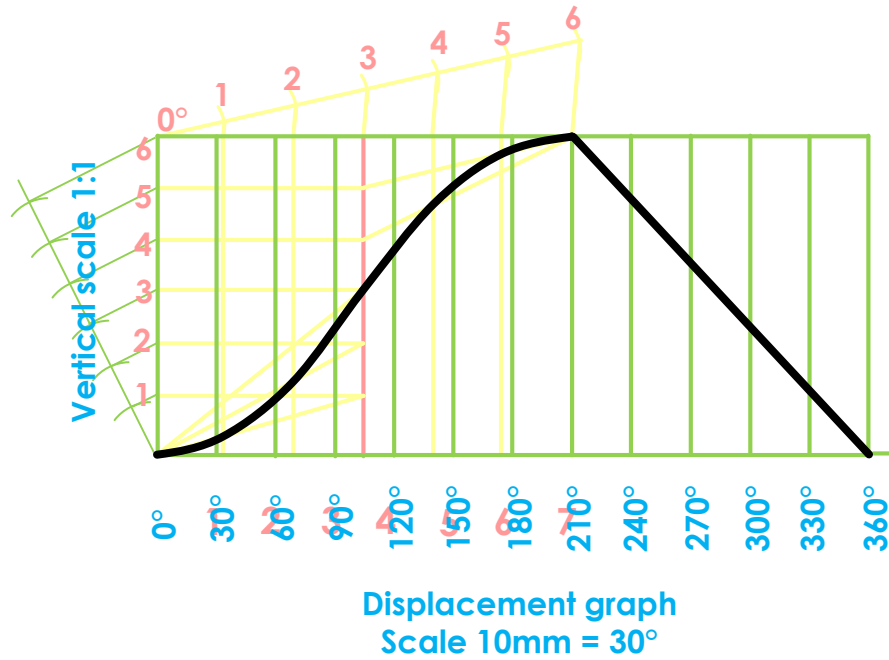

Anti-clockwise

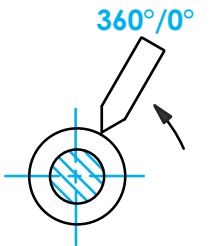

Loci of a CAM

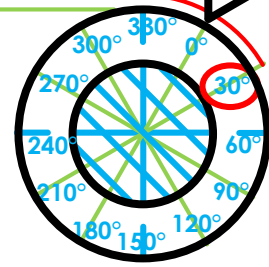
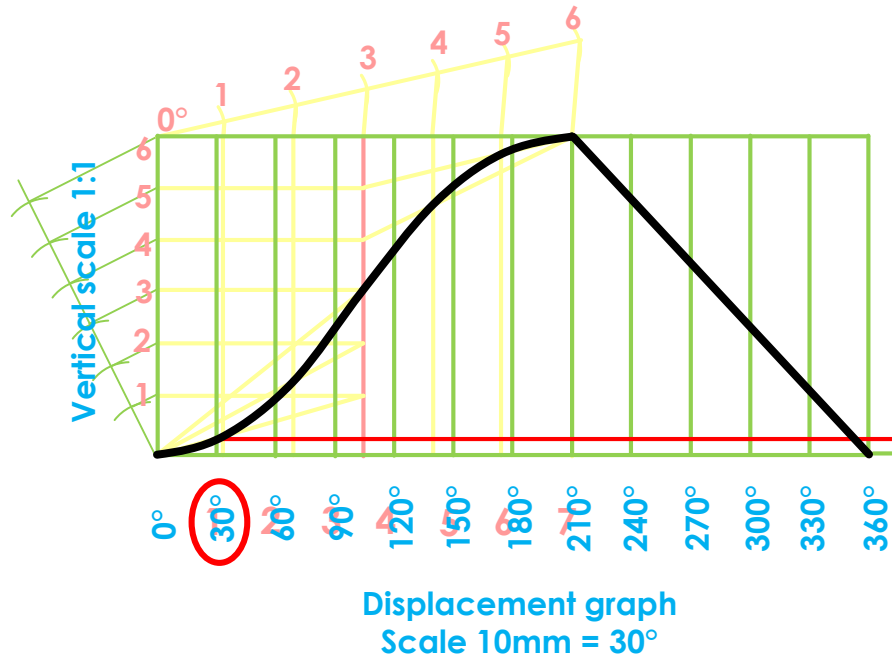

Anti-clockwise

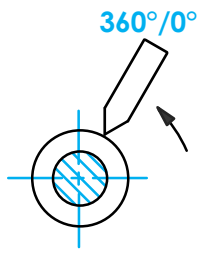

Loci of a CAM

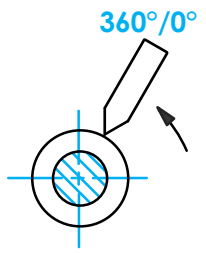
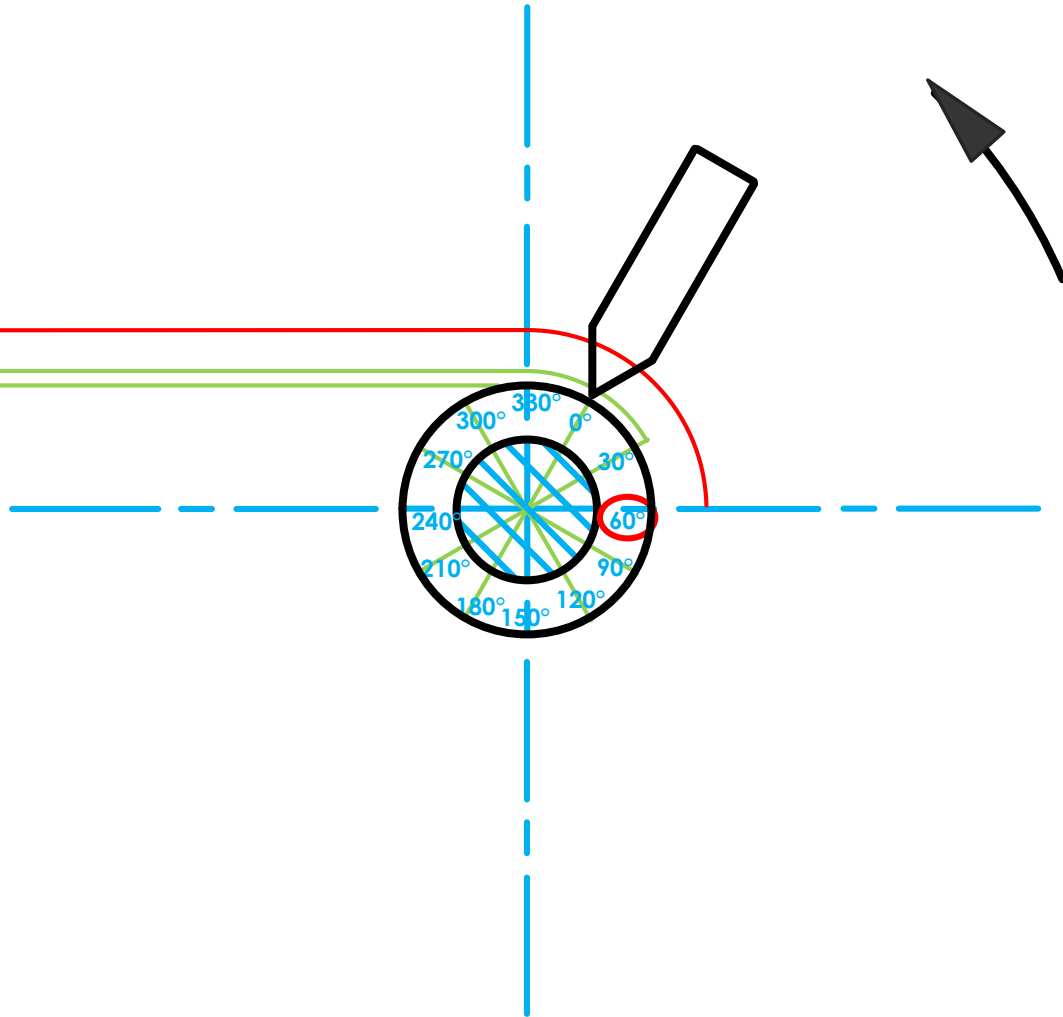
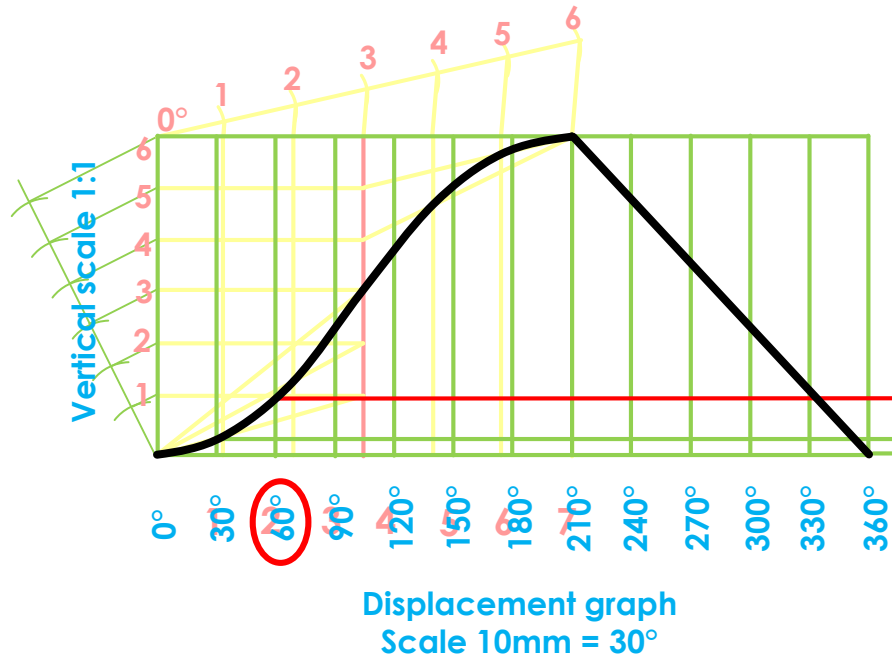

Loci of a CAM

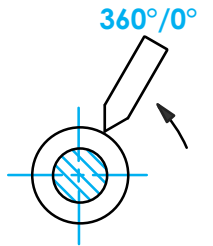
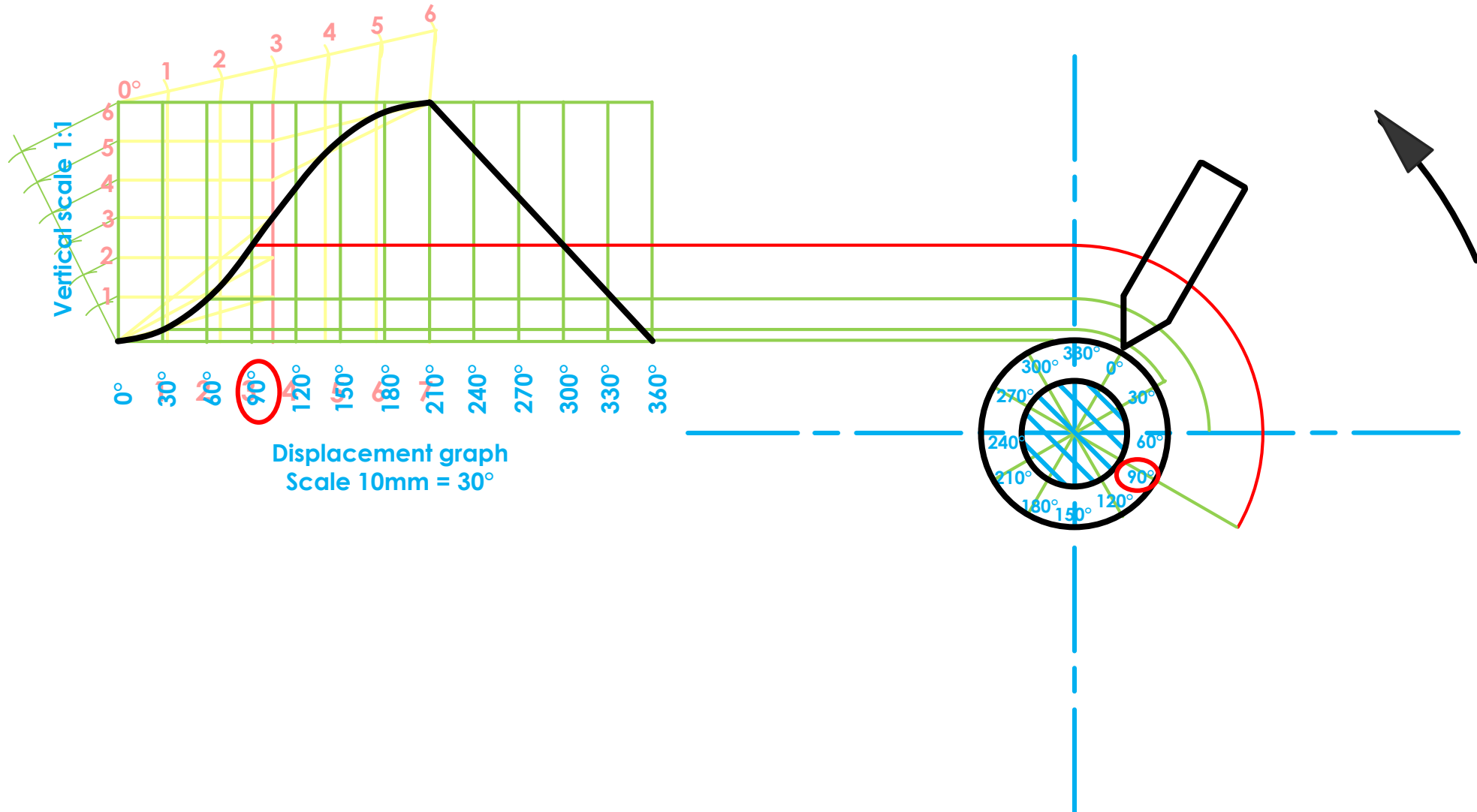

Loci of a CAM

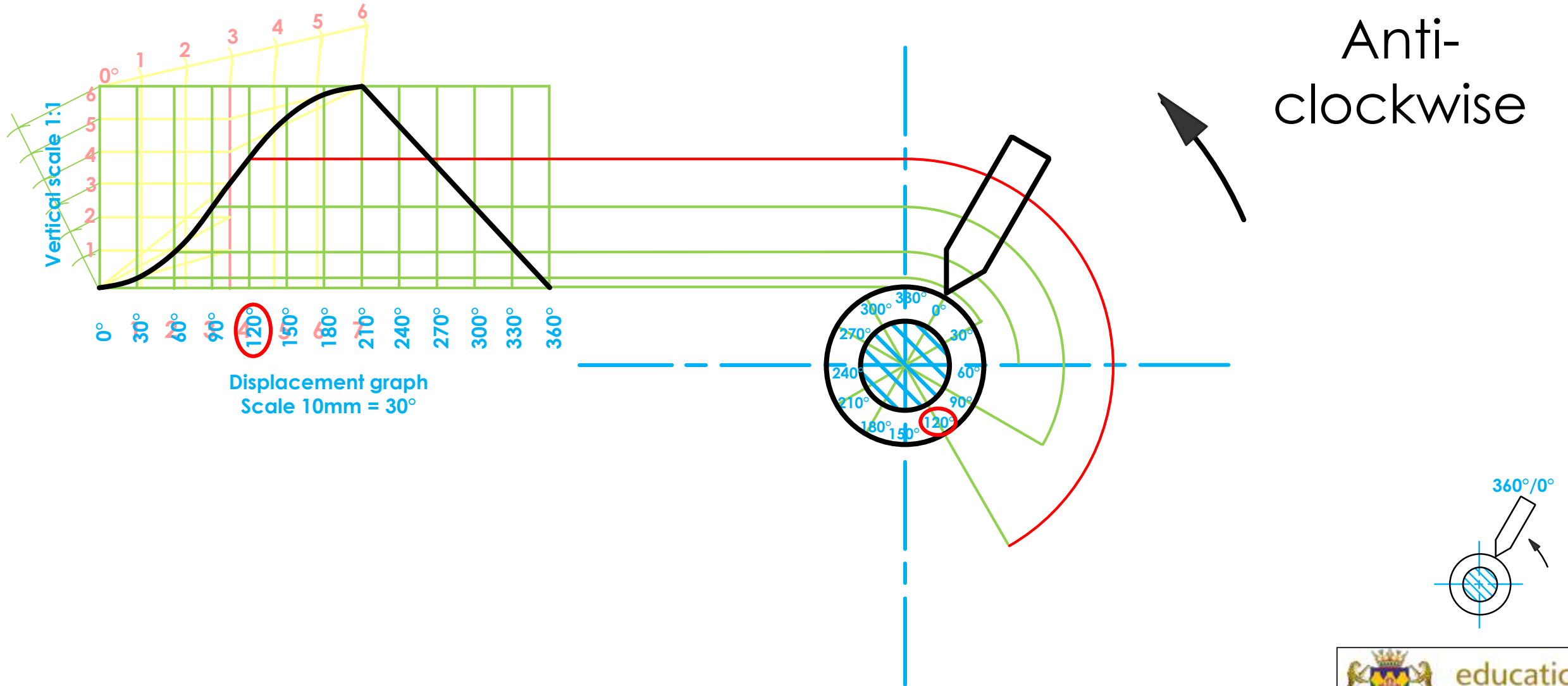

Loci of a CAM

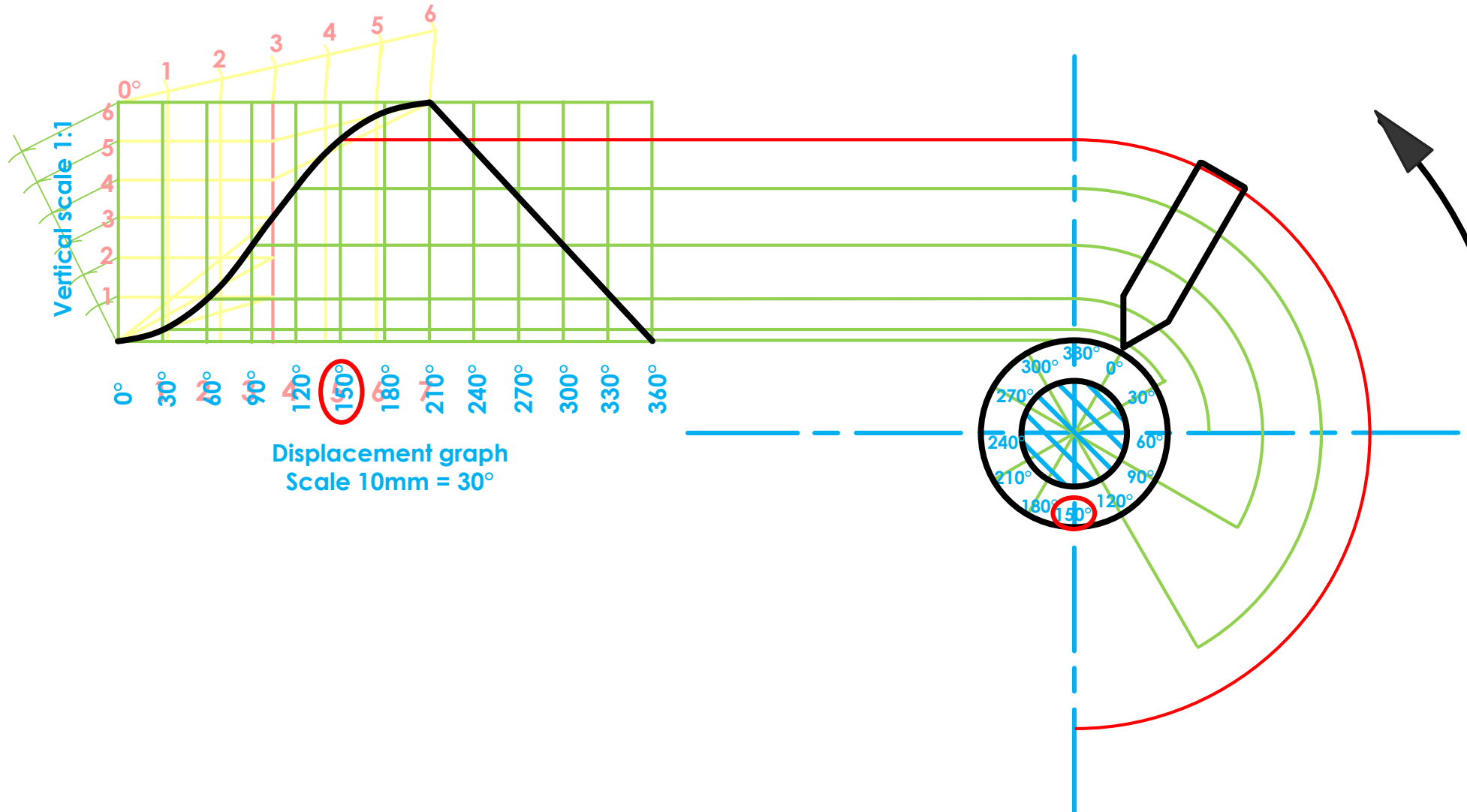

Anti-clockwise

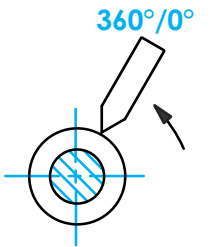

Loci of a CAM

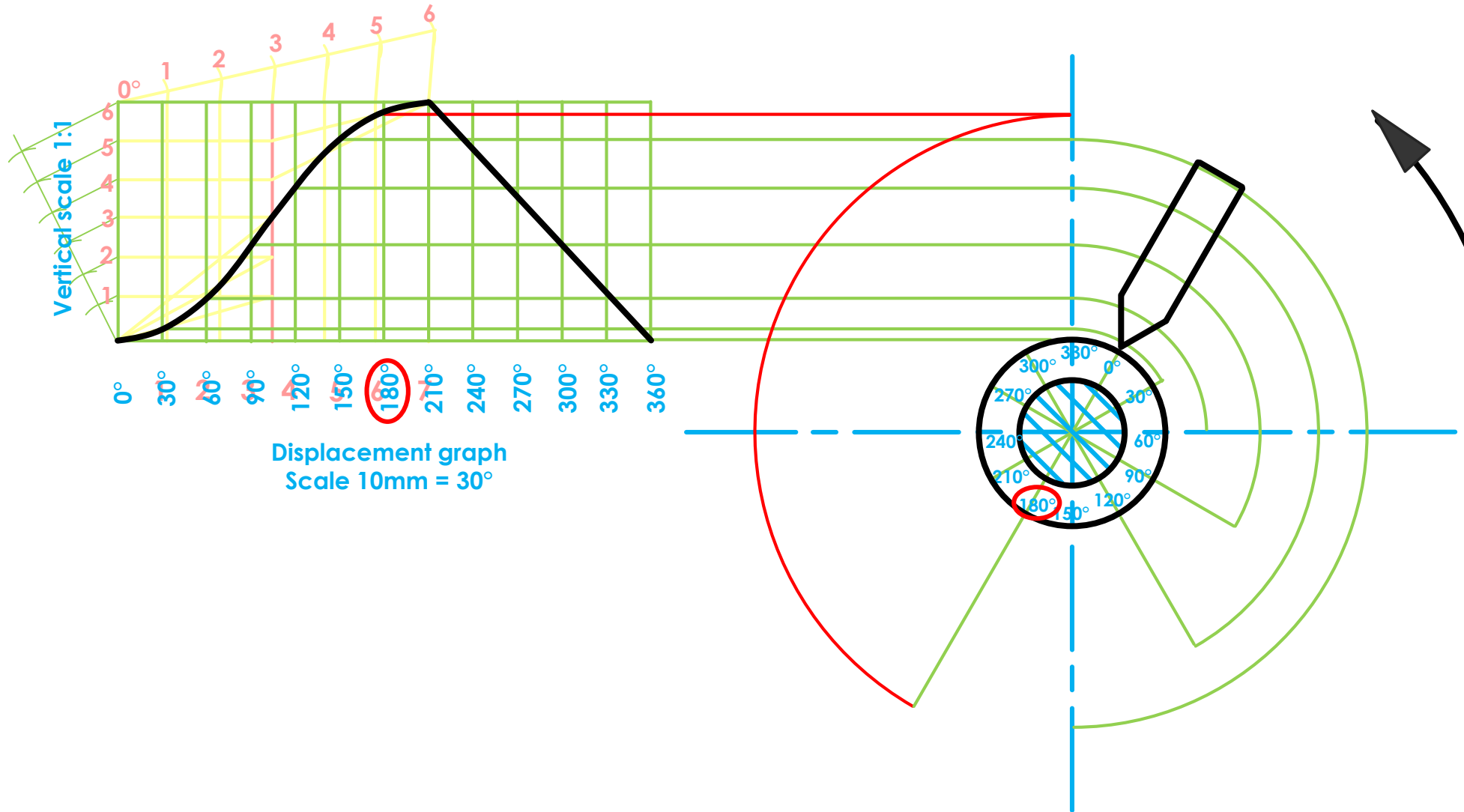

Anti-clockwise

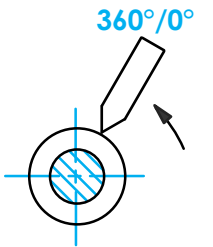

Loci of a CAM

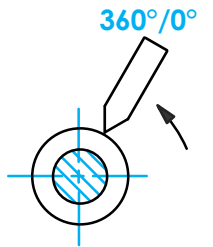
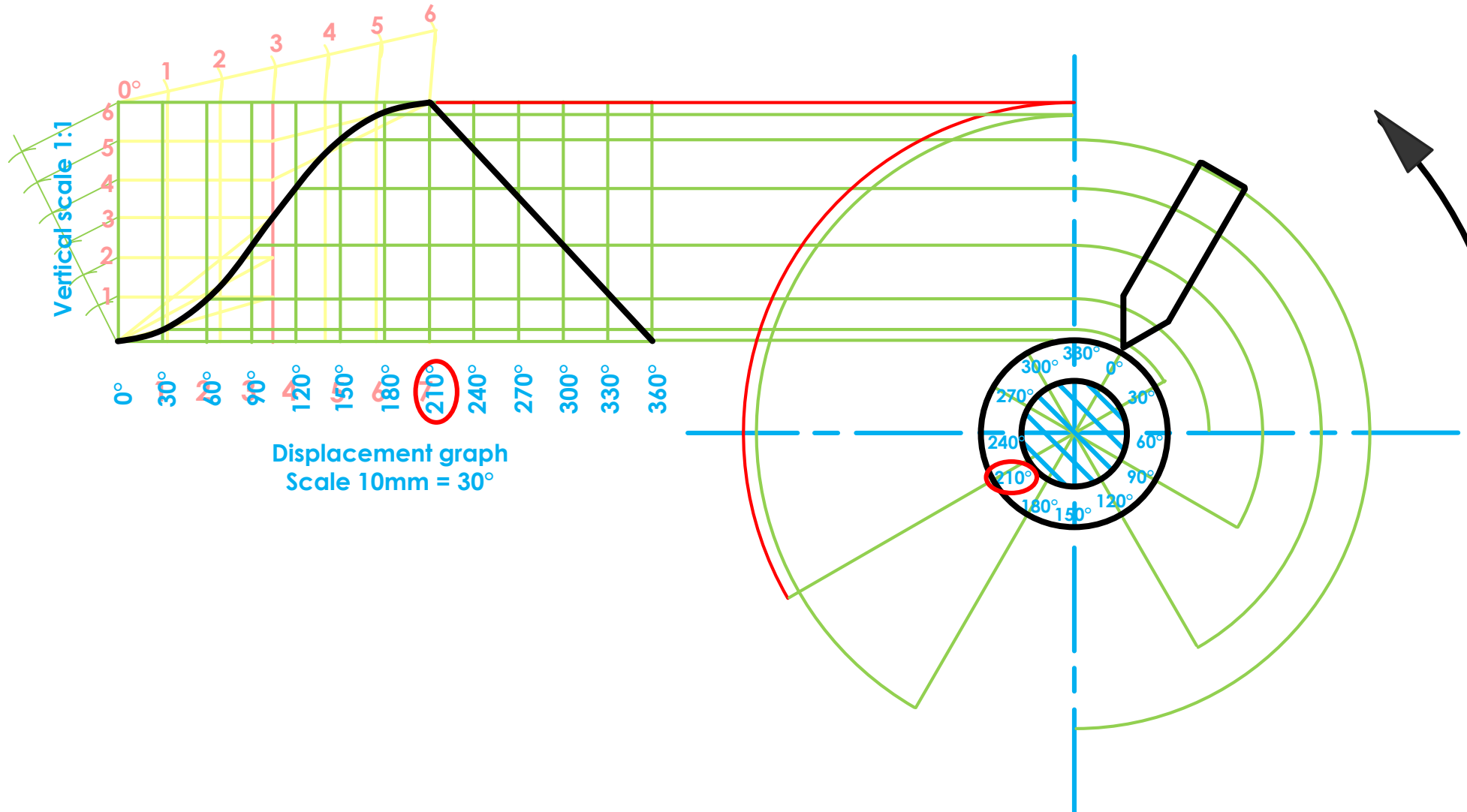

Loci of a CAM

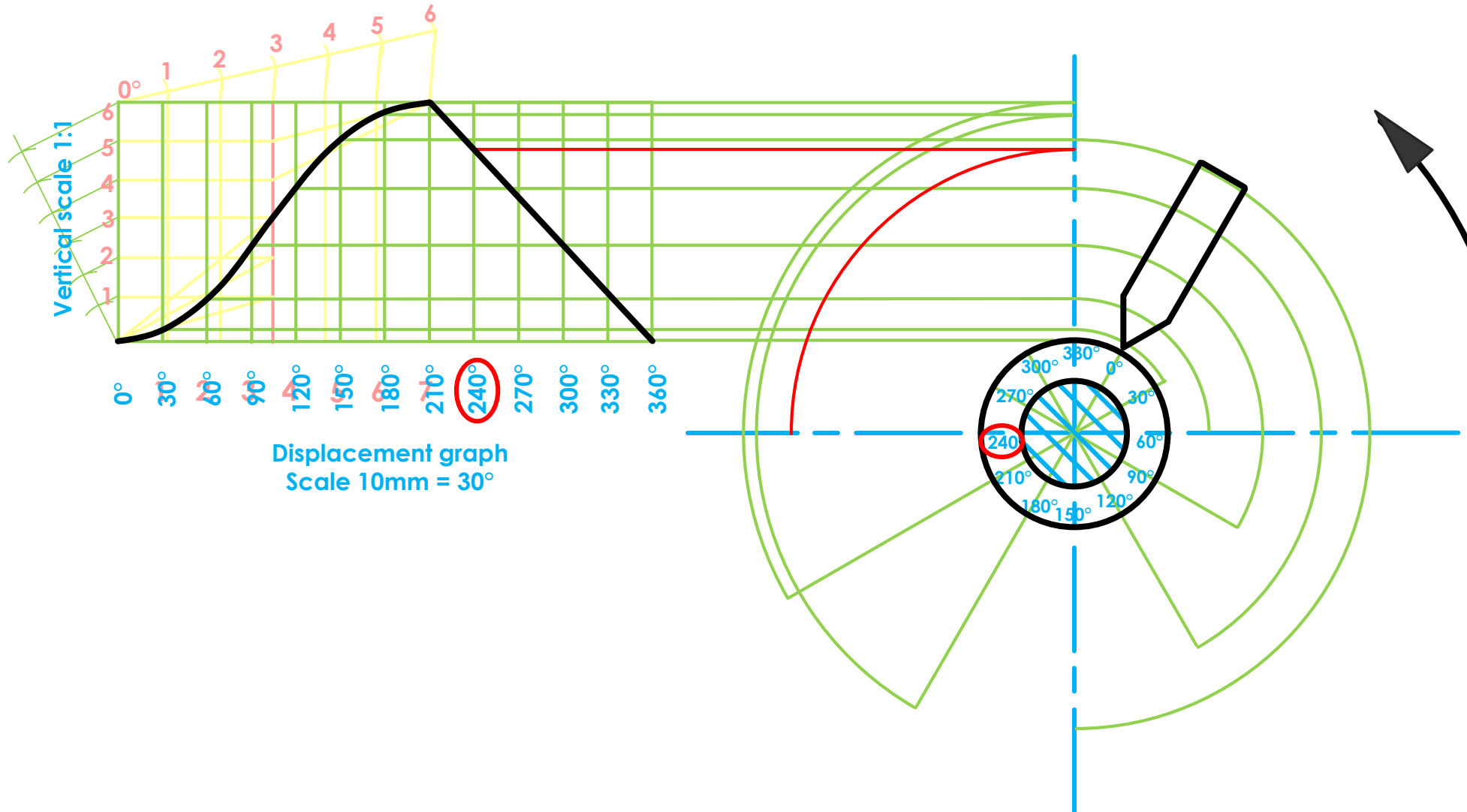

Anti-clockwise

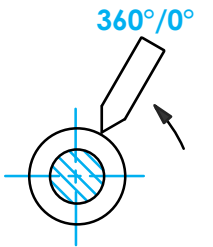

Loci of a CAM

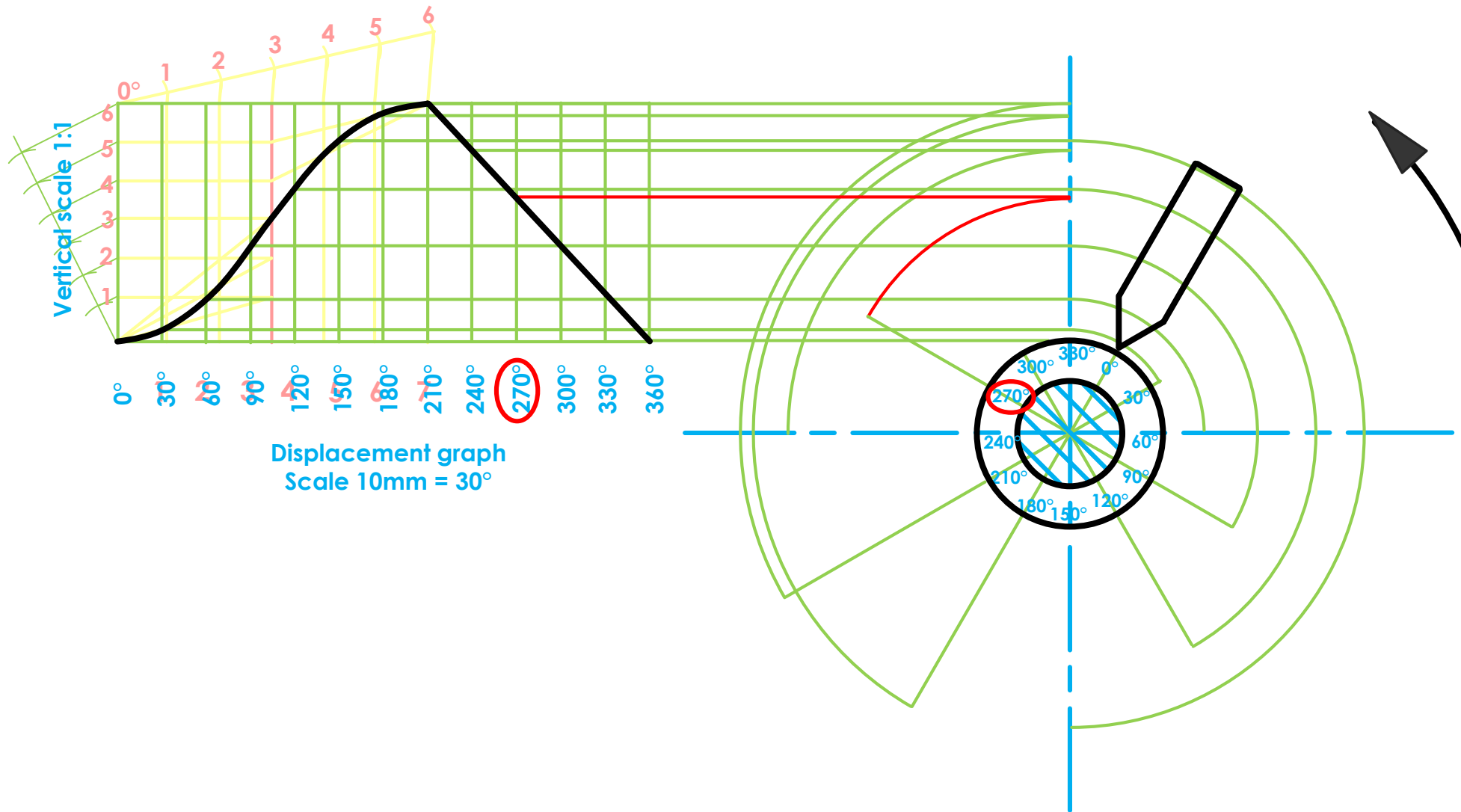

Anti-clockwise

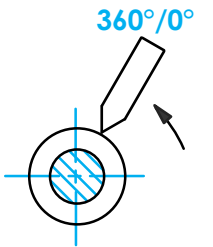

Loci of a CAM

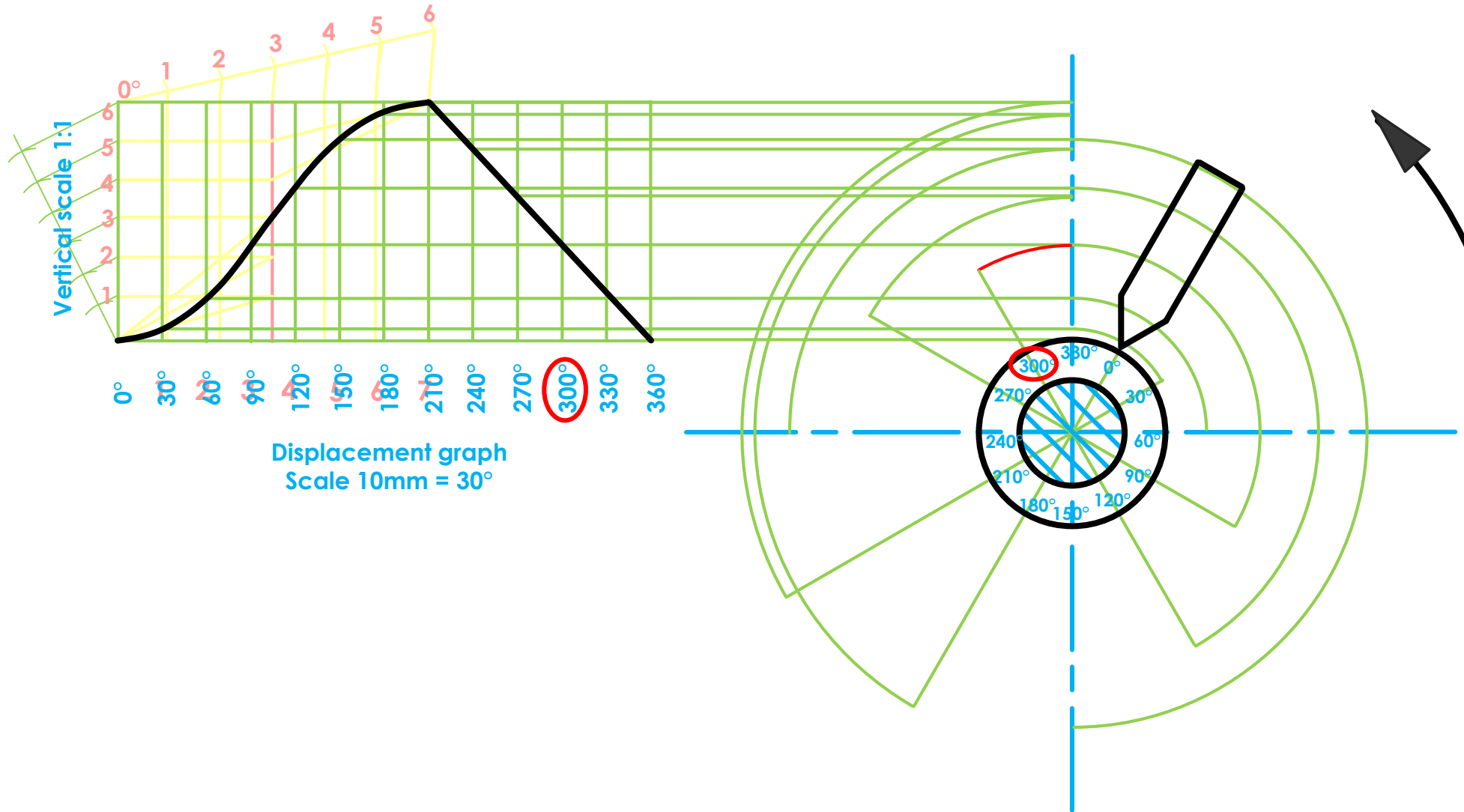

Anti-clockwise

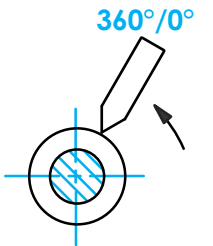

Loci of a CAM

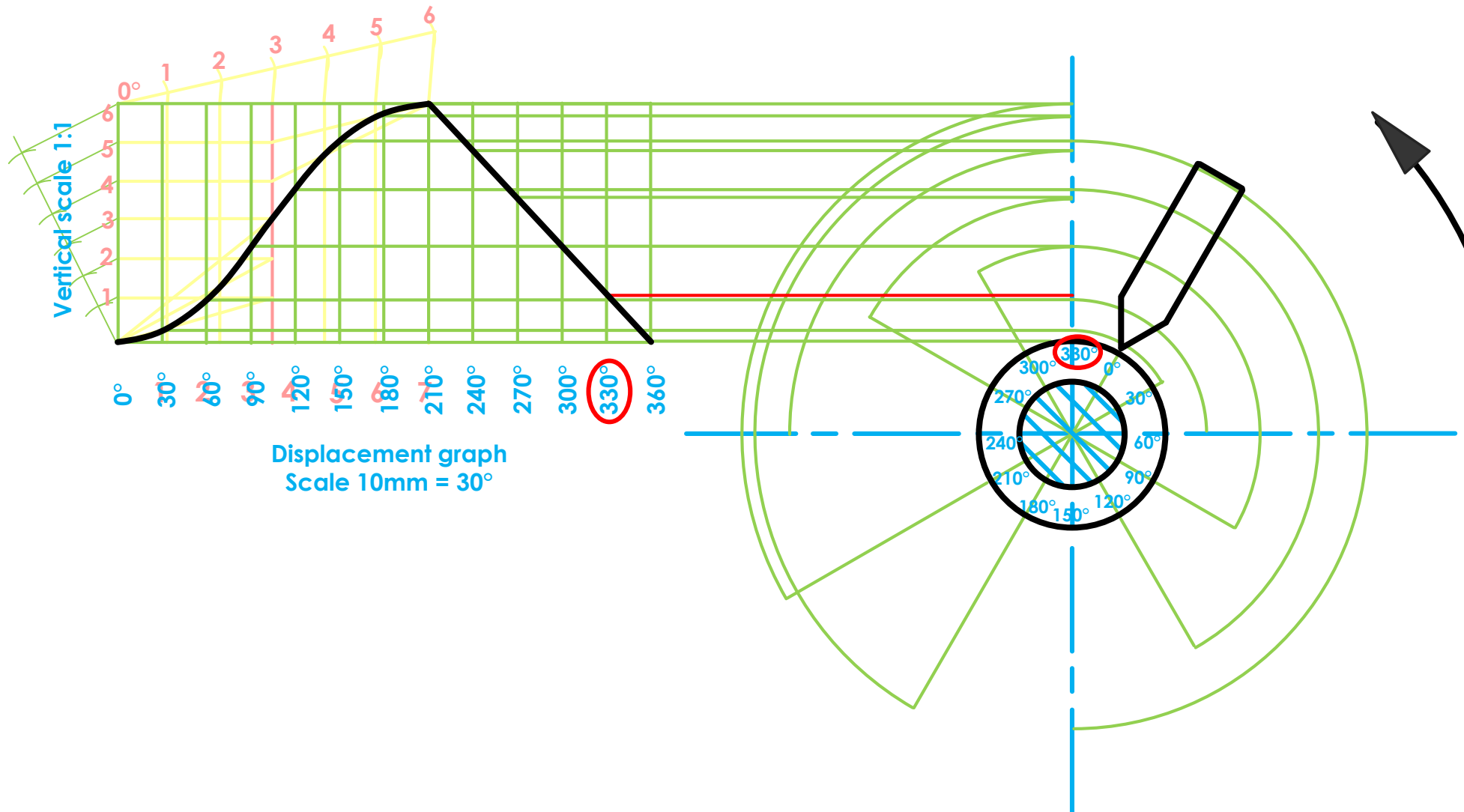

Anti-clockwise

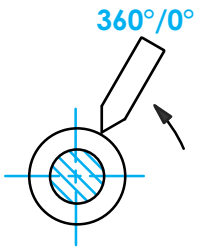

Loci of a CAM

