



education

Department of
Education
FREE STATE PROVINCE

ENGINEERING GRAPHICS AND DESIGN P2

GRADE 12

SEPTEMBER 2019

TIME: 3 HOURS

TOTAL: 100

This question paper consists of 6 pages.

INSTRUCTIONS AND INFORMATION

1. This question paper consists of FOUR questions
2. Answer ALL the questions.
3. ALL drawings are in third-angle orthographic projection, unless stated otherwise.
4. ALL drawings must be drawn to scale 1:1, unless stated otherwise.
5. ALL questions must be answered on the DIAGRAM SHEET, as instructed.
6. ALL the pages must be restapled in numeric sequence, irrespective of whether the question was attempted or not.
7. Time management is essential in order to complete all the questions.
8. Print your name and surname as well as the grade in the space provided on each page.
9. ALL answers must be drawn accurately and neatly.
10. ALL necessary construction and projection lines must be shown.
11. Plan each drawing carefully from the given position, which is indicated on the diagram sheets.
12. Any details or dimensions not given must be assumed in good proportion.

FOR OFFICIAL USE ONLY								
QUESTION	MARKS OBTAINED			½	MODERATED			½
1								
2								
3								
4								
TOTAL								
	2	0	0		2	0	0	

FINAL CONVERTED MARK	CHECKED BY
100	

NAME & SURNAME	MEMORANDUM	GRADE	12	1
----------------	------------	-------	----	---



QUESTION 2: LOCUS

Given:

A mechanism that consists of wheel AB. Link BG is joined with pin B to the wheel AB. The link BG slide through the fixed point C. Link GP is joined at BG at point G. Link GP slide through the fixed point at D.

Movement:

Wheel AB rotates in a clockwise direction with link BG that slides through point C. Link GP rotates with AB and link GP that slides through point D.

Instructions:

- 2.1 Draw to scale 1:1, the given schematic drawing, using point A as the starting point. Include all labels.
- 2.2 Determine the locus of point G for one rotation.
- 2.3 Determine the locus of point P for one rotation.

Note:

ALL constructions must be shown.

[40]

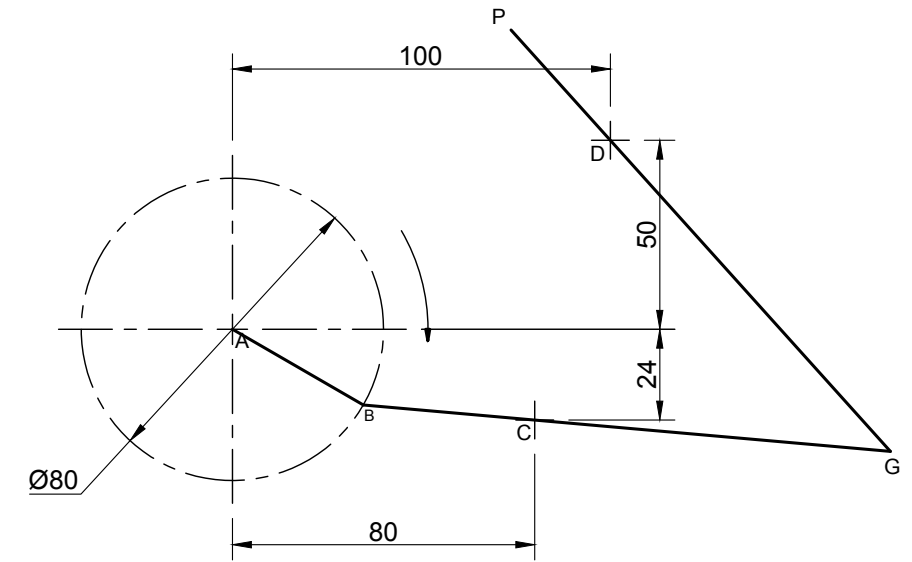
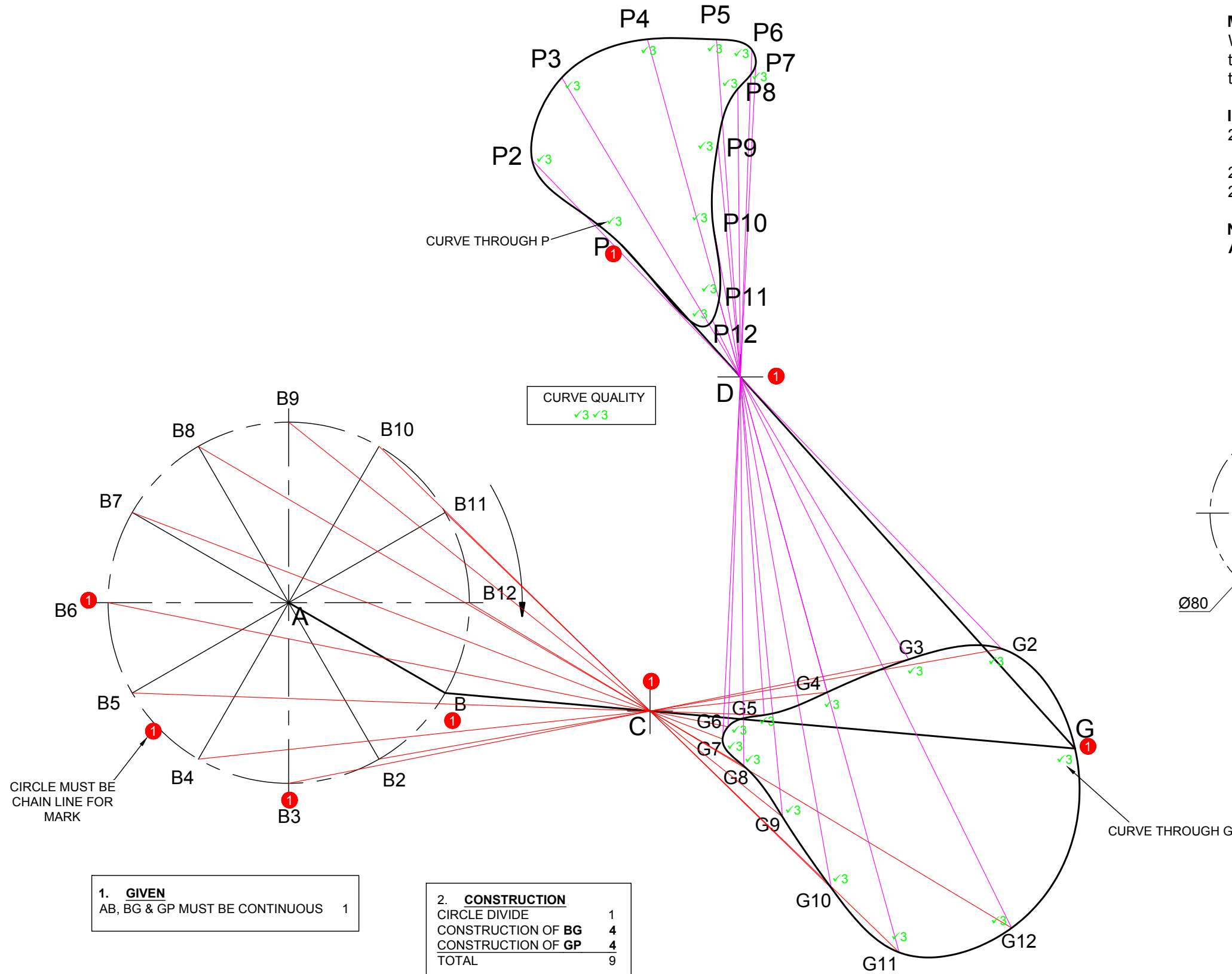

LINK BG = 140mm
LINK GP = 150mm

ASSESSMENT CRITERIA			
1	GIVEN	5	
2	CONSTRUCTION	9	
3	POINTS + CURVES	26	
TOTAL		40	

STAPEL

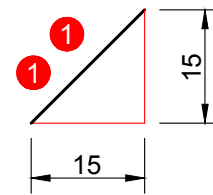
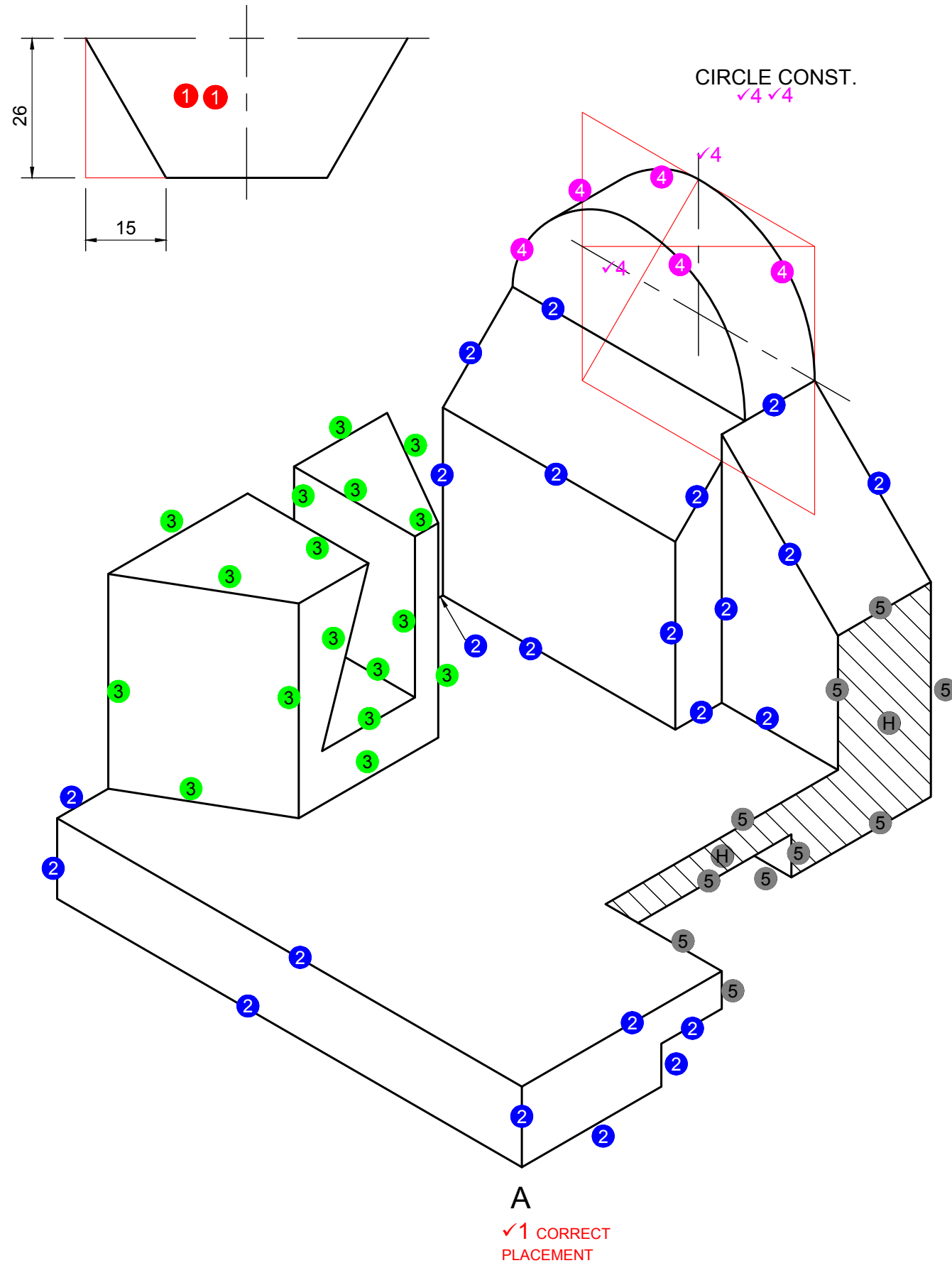

QUESTION 3: ISOMETRIC DRAWING

Given:

- The front-, left- and top view of a CASTING with cutting plane X-X.
- The position of point A on the drawing sheet.

Instructions:

Using scale 1:1, convert the orthographic view of the casting into a sectional isometric drawing in cutting plane X-X.

Note:

- Make A the lowest point of the drawing.
- Show ALL necessary constructions.
- NO hidden detail is required.

[35]

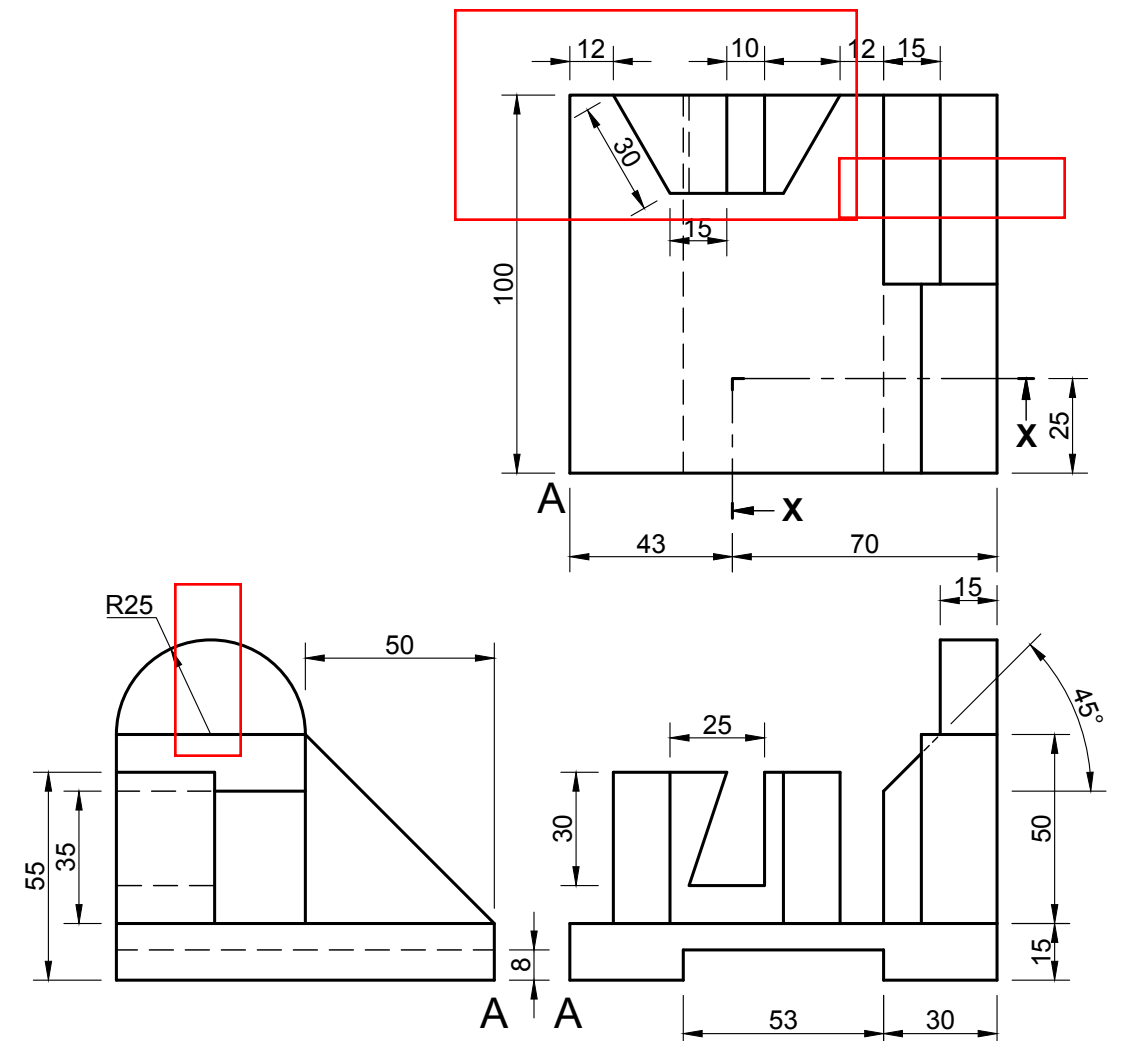

ASSESSMENT CRITERIA

1	PLACEMENT + AUXILIARY VIEW	3		
2	ISO- & NON ISOMETRIC LINES	11		
3	HEXAGON	8½		
4	CIRCLE + CIRCLE CONST. + CL	6½		
5	SECTION	6		
TOTAL		35		

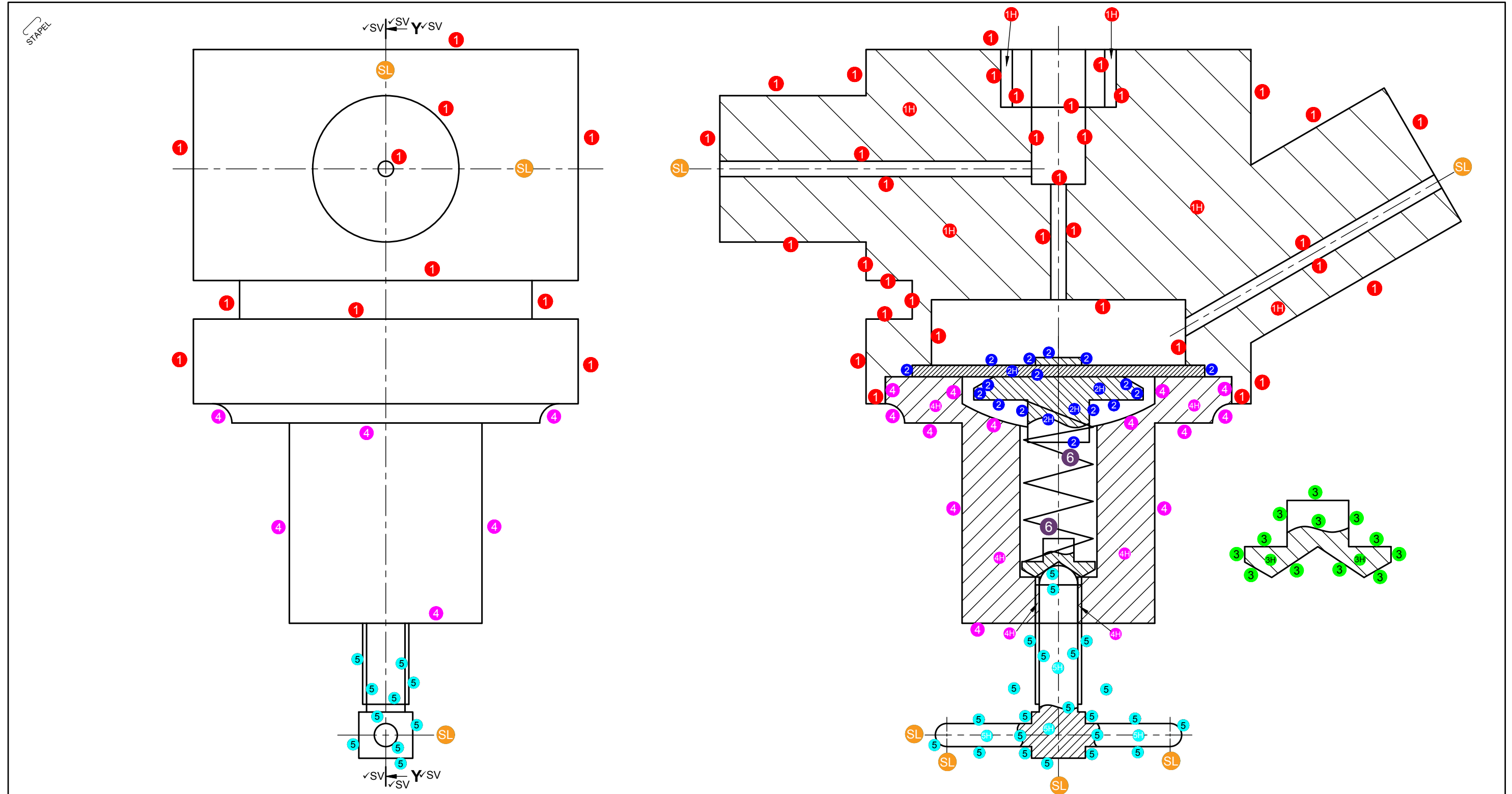

ASSESSMENT CRITERIA LEFT VIEW			
1	BODY	10½	
4	COVER	3	
5	SCREW	5	
SUB TOTAL 1		18½	

ASSESSMENT CRITERIA SECTIONAL FRONT VIEW			
1	BODY	20	
2	DIAPHRAGM	10	
3	LOCATER	7	
4	COVER	9	
5	SCREW	13	
6	SPRING	1	
SUB TOTAL 2		60	

ASSESSMENT CRITERIA TECHNICAL PROVISION			
1	CENTER LINES + CUTTING PLANE Y-Y	10½	
2	TITLE + SCALE	2	
3	PROJECTION SYMBOL	4	
SUB TOTAL 3		16½	
GRAND TOTAL		95	

TITLE	
GAS REGULATOR √T	
SCALE	
SCALE 1:1 √S	
PROJECTION SYMBOL	